

## High Voltage 8-CH LED Driver

### General Description

The RT8562B is a 40V 8-CH LED driver capable of delivering 30mA to each channel with 10 LEDs (3.6V per diode), total of 80 LEDs with one driver. The RT8562B is a current mode boost converter operated at 1MHz, wide  $V_{IN}$  range covers from 4.5V to 24V and the on-chip current switch is rated at 2.5A.

The PWM output voltage loop regulates the LED pins to 0.6V with an auto-adjustment circuit allowing voltage mismatches between LED strings. The RT8562B automatically detects and disconnects any unconnected and/or broken strings during operation from PWM loop to prevent  $V_{OUT}$  from over voltage.

The 1.5% matched LED currents on all channels are simply programmed with a resistor or a current sink. A very high contrast ratio true digital PWM dimming can be achieved by driving PWM pin with a PWM signal.

Other protecting features include programmable output over voltage protection, LED current limit, PWM switch current limit and thermal shutdown.

The RT8562B is packaged with a tiny footprint package of WQFN-24L 4x4 packages.

### Ordering Information

RT8562B □ □

- Package Type  
QW : WQFN-24L 4x4 (W-Type)
- Lead Plating System  
G : Green (Halogen Free and Pb Free)

Note :

Richtek products are :

- ▶ RoHS compliant and compatible with the current requirements of IPC/JEDEC J-STD-020.
- ▶ Suitable for use in SnPb or Pb-free soldering processes.

### Marking Information

For marking information, contact our sales representative directly or through a Richtek distributor located in your area.

### Features

- **High Voltage** :  $V_{IN}$  up to 24V,  $V_{OUT}$  up to 40V, Driving up to 80 x 3.6V LEDs (10 each channel)
- **Channel Current Programmable 10mA to 30mA and Matched to 1.5%**
- **Current Mode PWM 1MHz Boost Converter**
- **Easy and High Accuracy Digital Dimming by PWM Signal**
- **Programmable Soft-Start**
- **Automatic Detecting Unconnected and/or Broken Channel**
- **Programmable Over Voltage Protection**
- **Disconnects LED in Shutdown**
- **$V_{IN}$  Under Voltage Lockout**
- **Over Temperature Protection**
- **Current Limiting Protection**
- **Small 24-Lead WQFN Package**
- **RoHS Compliant and Halogen Free**

### Applications

- UMPC and Notebook Computer Backlight
- GPS, Portable DVD Backlight
- Desk Lights and Room Lighting

### Pin Configurations

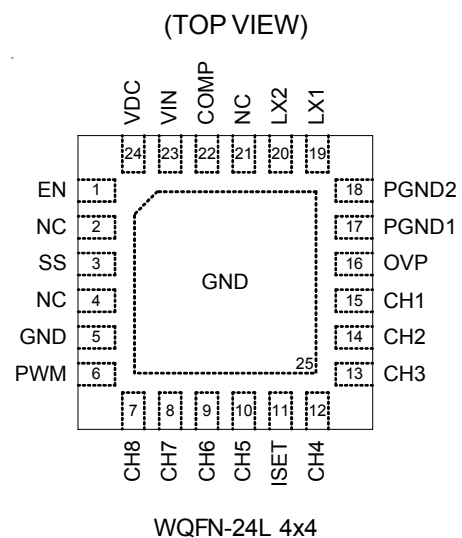

## Typical Application Circuit

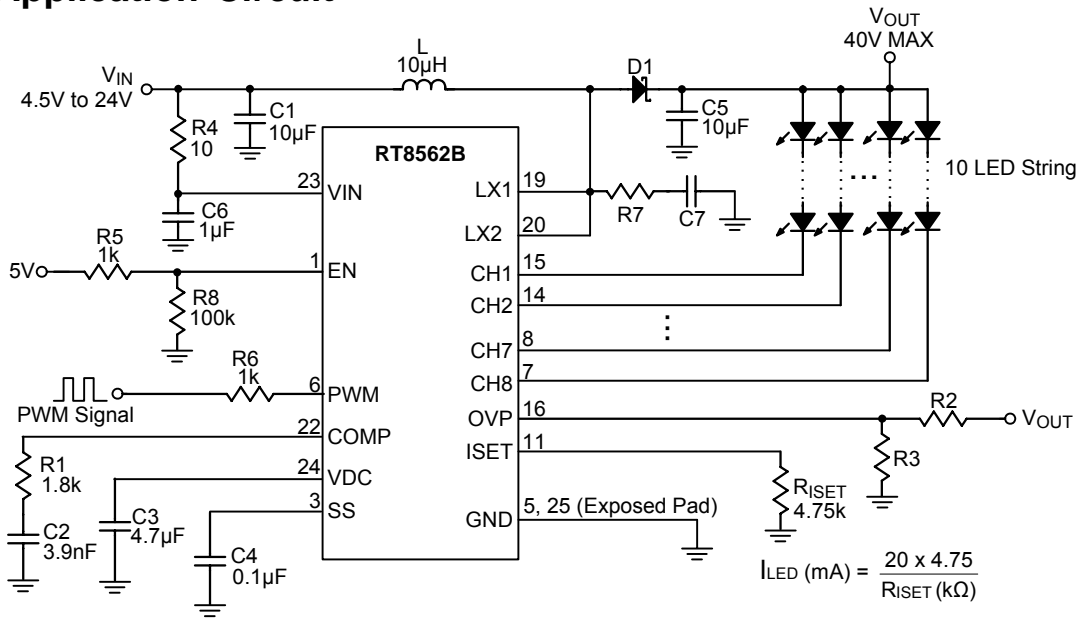

Note :

1. Due to the limitaion of maximum duty 5V input can support typically to  $V_{OUT} = 33V$ .
2. Due to the limitaion of maximum duty 4V input can support typically to  $V_{OUT} = 26V$ .

Figure 1. 1MHz, 20mA Full Scale Current PWM Dimming Control

## Function Block Diagram

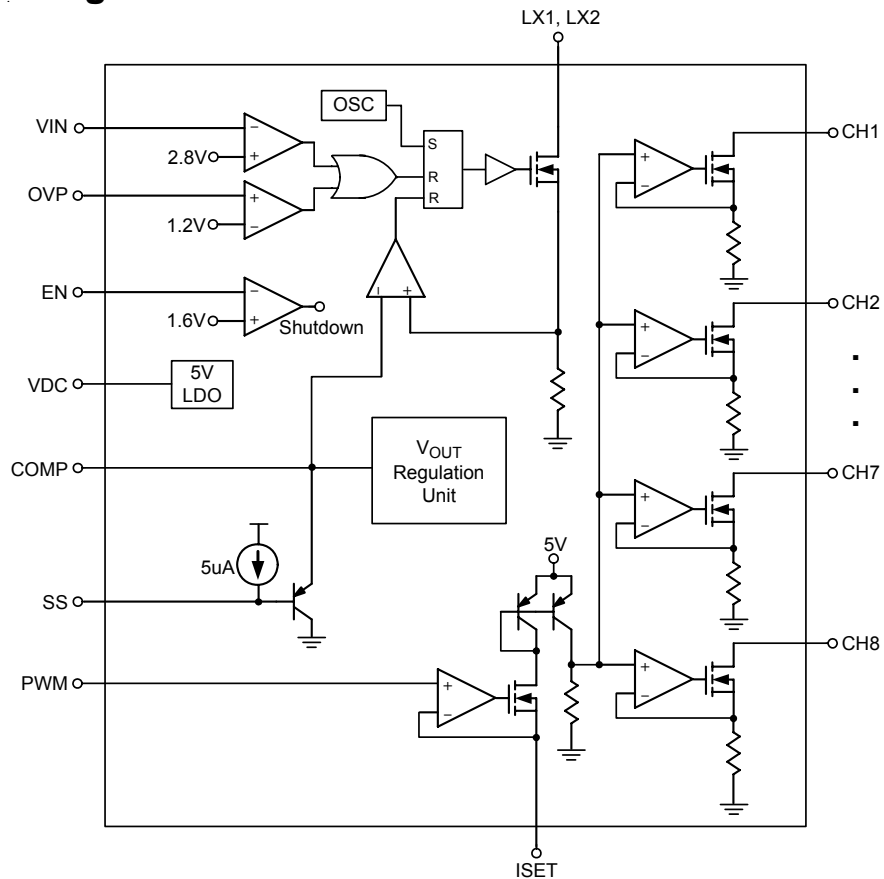

**Functional Pin Description**

Pin No.	Pin Name	Pin Function
1	EN	Chip enable pin, when pulled low, chip is in shutdown mode. There should be a pull low 100kΩ resistor connected to GND when the control signal is floating.
2, 4, 21	NC	No Internal Connection.
3	SS	Soft-Start pin, a capacitor of at least 10nF is required for soft start.
5, 25 (Exposed Pad)	GND	Ground pin of the chip. The exposed pad must be soldered to a large PCB and connected to GND for maximum power dissipation.
6	PWM	Digital Dimming Control.
11	ISET	A resistor or a current from DAC on this pin programs the full LED current.
10, 9, 8, 7	CH5 to CH8	Channel 5 to Channel 8 LED Current Sink. Leave the pin unconnected if not used.
15, 14, 13, 12	CH1 to CH4	Channel 1 to Channel 4 LED Current Sink. Leave the pin unconnected if not used.
16	OVP	Over Voltage Protection. PWM boost converter turns off when $V_{OVP}$ goes higher than 1.2V.
17, 18	PGND1, PGND2	Power Ground (LX1/LX2 power return).
19, 20	LX1, LX2	PWM boost converter switch node.
22	COMP	PWM boost converter loop compensation node.
23	VIN	Power supply of the chip. For good bypass, a low ESR capacitor is required.
24	VDC	Put 1μF capacitor on this pin to stabilize the 5V output of the internal regulator. This regulator is for chip internal use only.

## Absolute Maximum Ratings (Note 1)

- Supply Voltage,  $V_{IN}$  ----- 28V
- LX1, LX2 Pin Voltage at Switching Off ----- 50V
- CH1 to CH8 Pin ----- 50V
- PWM, EN, OVP Pin Voltage ----- -0.3V to 5.5V
- Power Dissipation,  $P_D$  @  $T_A = 25^\circ\text{C}$   
 WQFN-24L 4x4 ----- 1.923W
- Package Thermal Resistance (Note 2)  
 WQFN-24L 4x4,  $\theta_{JA}$  -----  $52^\circ\text{C/W}$   
 WQFN-24L 4x4,  $\theta_{JC}$  -----  $7^\circ\text{C/W}$
- Junction Temperature -----  $150^\circ\text{C}$
- Lead Temperature (Soldering, 10 sec.) -----  $260^\circ\text{C}$
- Storage Temperature Range -----  $-65^\circ\text{C}$  to  $150^\circ\text{C}$
- ESD Susceptibility (Note 3)  
 HBM (Human Body Mode) ----- 2kV  
 MM (Machine Mode) ----- 200V

## Recommended Operating Conditions (Note 4)

- Supply Input Voltage,  $V_{IN}$  ----- 4.5V to 24V
- Junction Temperature Range -----  $-40^\circ\text{C}$  to  $125^\circ\text{C}$
- Ambient Temperature Range -----  $-40^\circ\text{C}$  to  $85^\circ\text{C}$

## Electrical Characteristics

( $V_{IN} = 17\text{V}$ ,  $T_A = 25^\circ\text{C}$ , unless otherwise specified)

Parameter	Symbol	Test Conditions	Min	Typ	Max	Unit
Supply Current	$I_{VIN}$	$COMP \leq 0.2\text{V}$ (Switching off)	--	3	5	mA
$V_{IN}$ Under Voltage Lockout Threshold	$V_{UVLO}$	$V_{IN}$ Rising	--	2.8	3.5	V
		Hysteresis	--	0.4	--	
Shutdown Current	$I_{SHDN}$	$V_{EN} \leq 0.7\text{V}$	--	--	10	$\mu\text{A}$
EN Pin Input Current	$I_{EN}$	$V_{EN} \leq 5\text{V}$	--	--	0.1	$\mu\text{A}$
EN Voltage Input	Logic-High	$V_{EN\_H}$	1.6	--	5.5	V
	Logic-Low	$V_{EN\_L}$	--	--	1	
PWM Voltage Input	Logic-High	$V_{PWM\_H}$	1.3	--	5	V
	Logic-Low	$V_{PWM\_L}$	--	--	0.65	
<b>LED Current Programming</b>						
LED Current	$I_{CHx}$	$2\text{V} > V_{CHx} > 0.6\text{V}$ , $R_{ISET} = 4.75\text{k}\Omega$ , $V_{PWM} > 1.2\text{V}$	19	20	21	mA
LEDs Current Matching		$2\text{V} > V_{CHx} > 0.6\text{V}$ , $R_{ISET} = 4.75\text{k}\Omega$ , $V_{PWM} > 1.2\text{V}$ , Calculating $(I_{(MAX)} - I_{(MIN)}) / I_{Average} \times 100\%$	--	--	1.5	%
ISET Pin Voltage	$V_{ISET}$	$3.6\text{k}\Omega \leq R_{ISET} \leq 9.6\text{k}\Omega$ , $V_{PWM} > 1.2\text{V}$	1.17	1.2	1.23	V
Input Current of PWM	$I_{PWM}$	$V_{IN} = 12\text{V}$ , $V_{EN} = 3.3\text{V}$ , $V_{PWM} = 5.5\text{V}$	--	1	--	$\mu\text{A}$
Threshold of PWM	$V_{PWM}$	LED Current Off	--	--	0.65	V
$V_{CHx}$ Threshold		Un-connection	--	0.1	--	V

To be continued

Parameter	Symbol	Test Conditions	Min	Typ	Max	Unit
<b>PWM Boost Converter</b>						
Switching Frequency			0.8	1	1.2	MHz
Minimum On Time			--	100	--	ns
Regulated $V_{CHx}$		Highest Voltage LED String	0.5	0.6	0.7	V
Amplifier (gm) Output Current		$2.4V > COMP > 0.2V$	--	$\pm 15$	--	$\mu A$
COMP Threshold		PWM Switch Off	0.1	0.2	--	V
LX1, LX2 $R_{DS(ON)}$			--	0.3	0.5	$\Omega$
LX1, LX2 Current Limit	$I_{LIM}$		2.5	--	--	A
SW Maximum Duty			--	88	--	%
<b>OVP &amp; Soft Start</b>						
OVP Threshold	$V_{OVP}$		1.1	1.2	1.3	V
OVP Input Current	$I_{OVP}$	$V_{OVP} \leq 3V$	--	--	50	nA
Soft Start Current	$I_{SS}$	$V_{SS} \leq 2.5V$	3	5	8	$\mu A$
Thermal Shutdown Temperature	$T_{SD}$		--	150	--	$^{\circ}C$
Thermal Shutdown Hysteresis			--	20	--	$^{\circ}C$

**Note 1.** Stresses listed as the above "Absolute Maximum Ratings" may cause permanent damage to the device. These are for stress ratings. Functional operation of the device at these or any other conditions beyond those indicated in the operational sections of the specifications is not implied. Exposure to absolute maximum rating conditions for extended periods may remain possibility to affect device reliability.

**Note 2.**  $\theta_{JA}$  is measured in the natural convection at  $T_A = 25^{\circ}C$  on a high-effective four layers thermal conductivity test board of JEDEC 51-7 thermal measurement standard. The case point of  $\theta_{JC}$  is on the expose pad for the WQFN package.

**Note 3.** Devices are ESD sensitive. Handling precaution is recommended.

**Note 4.** The device is not guaranteed to function outside its operating conditions.

Typical Operating Characteristics

Efficiency vs. Input Voltage

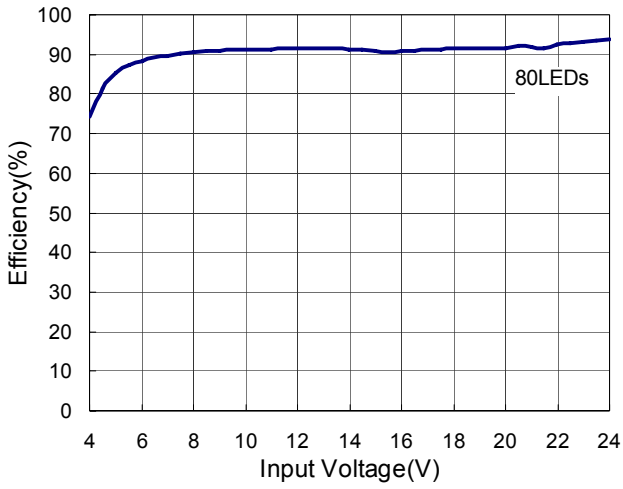

LED Current vs. Input Voltage

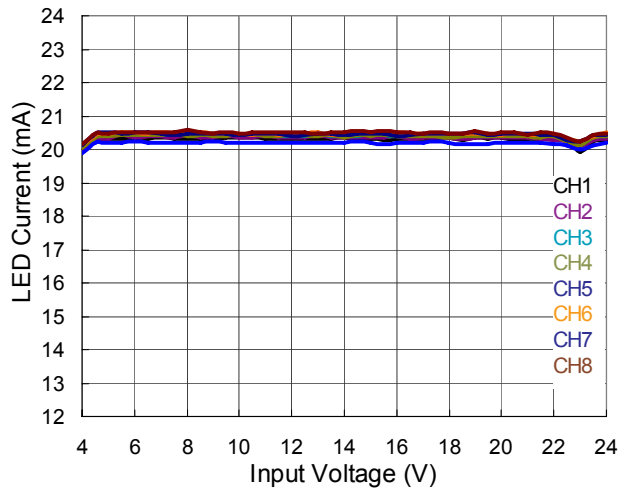

LED Current vs. Temperature

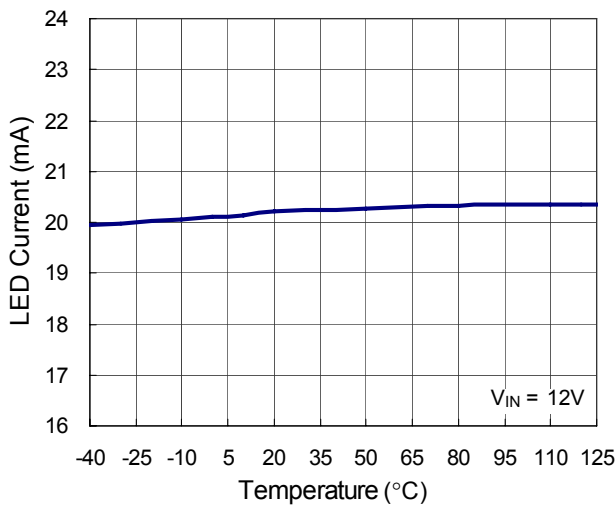

V<sub>SET</sub> vs. Temperature

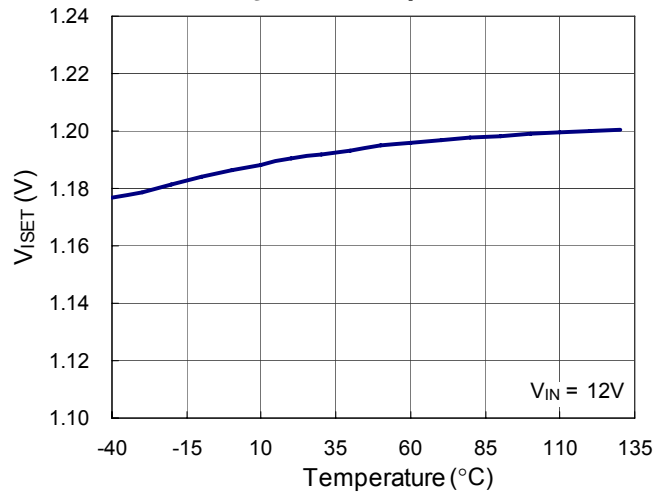

V<sub>SET</sub> vs. Input Voltage

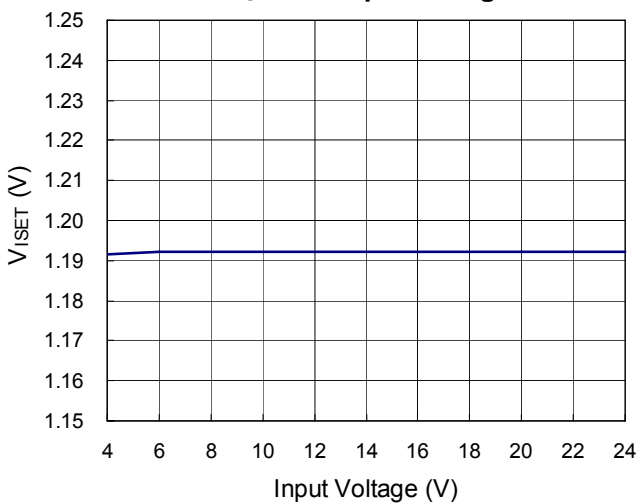

LED Current vs. PWM Duty Cycle

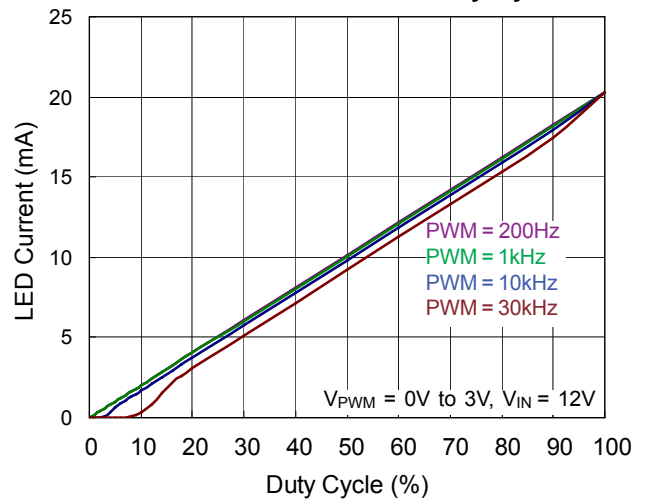

**Shutdown Current vs. Input Voltage**

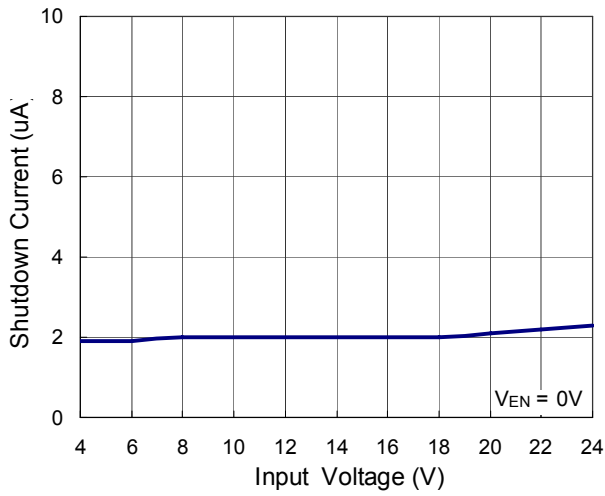

**Shutdown Current vs. Temperature**

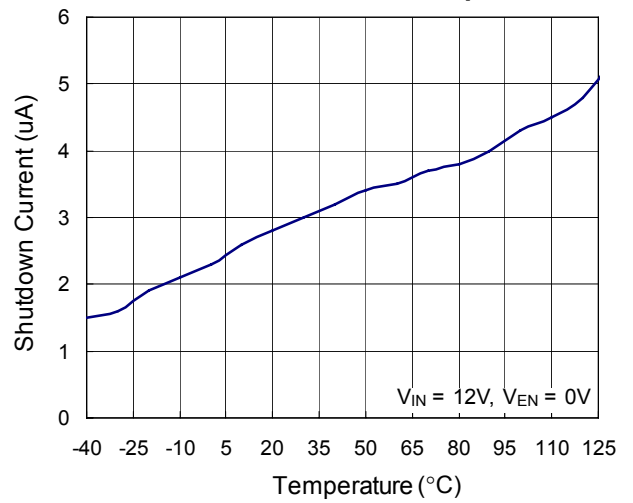

**Switch Off Current vs. Input Voltage**

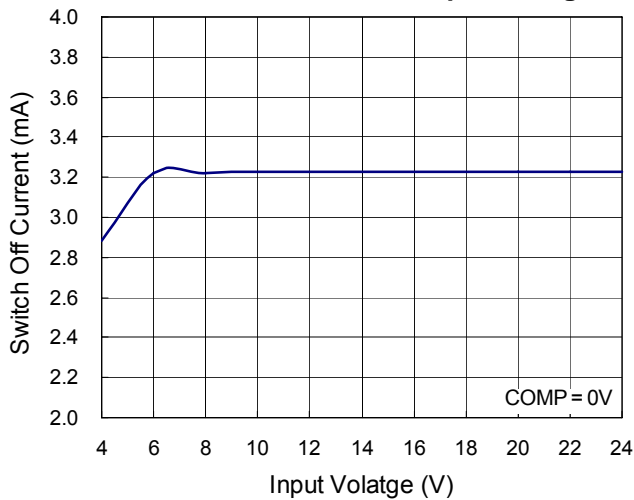

**SS Current vs. Temperature**

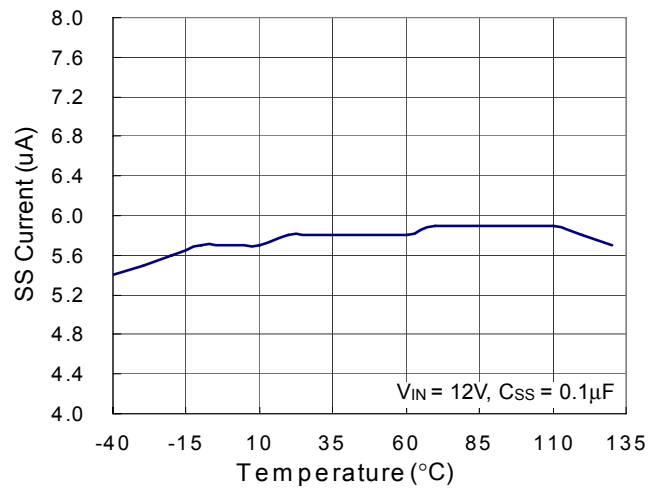

**SS Current vs. Input Voltage**

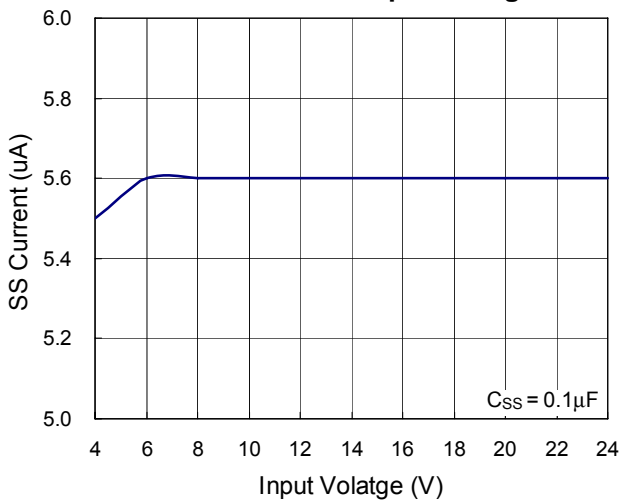

**OVP Voltage vs. Temperature**

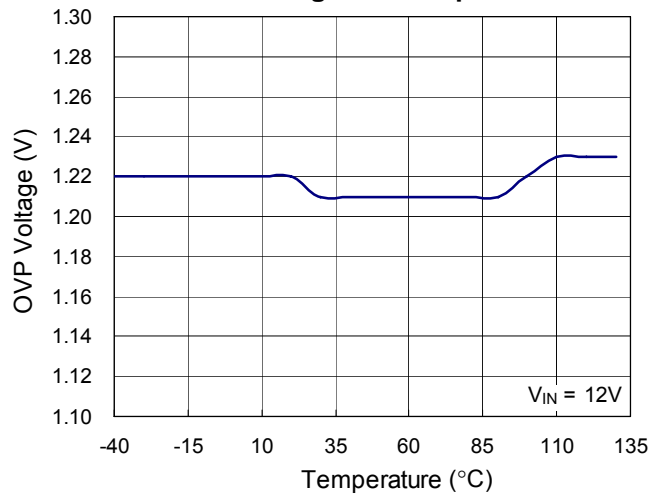

OVP Voltage vs. Input Volatge

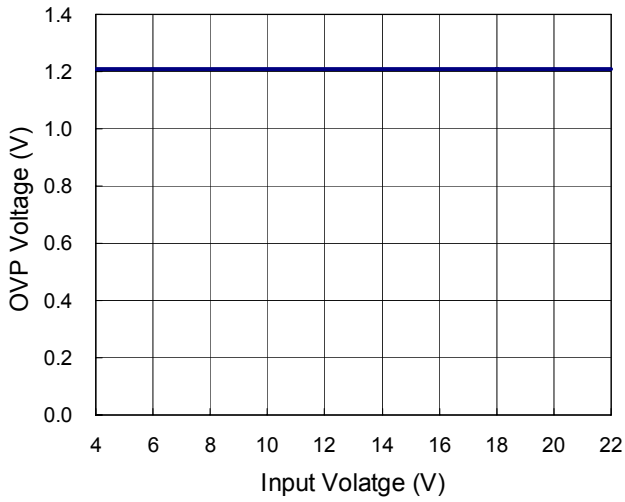

Line Transient Response

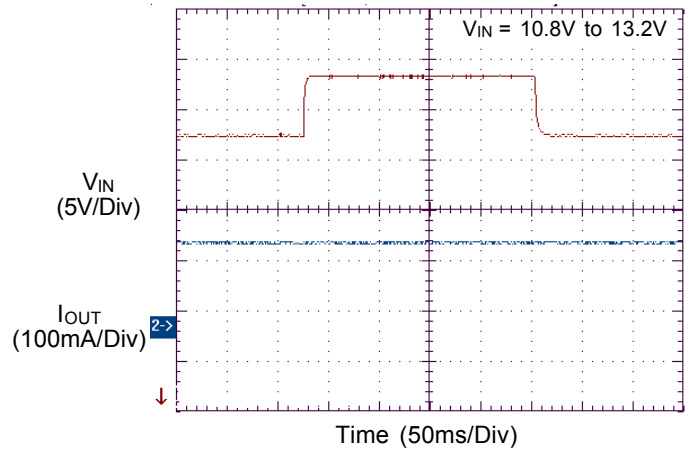

Power On from EN

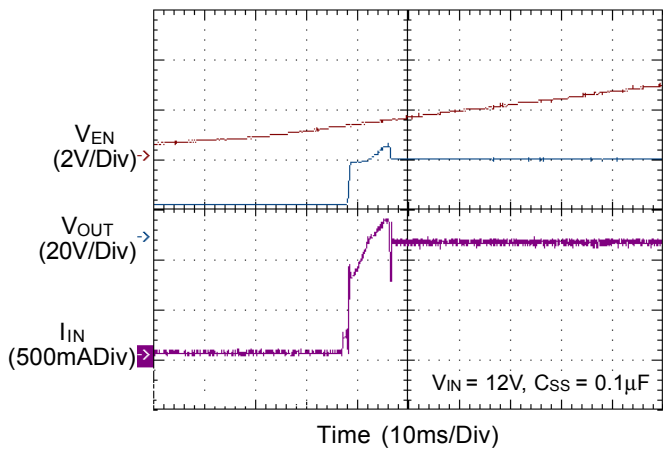

OVP

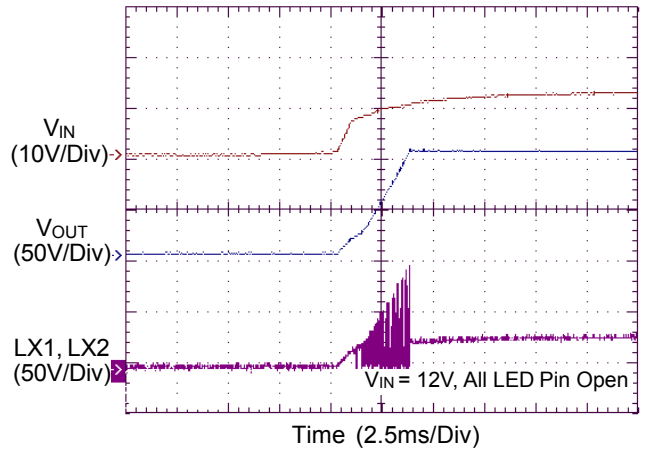



## Applications Information

The RT8562B is a current mode boost converter operating at 1MHz to power up to 80 white LEDs with a programmable current for uniform intensity. The part integrates current sources, soft-start, and easy analog and digital dimming control. The protection block provides the circuitry for over-temperature, over-voltage and current-limit protection features.

### Input UVLO

The input operating voltage range of the RT8562B is 4.5V to 24V. An input capacitor at the VIN pin can reduce ripple voltage. It is recommended to use a ceramic 10µF or larger capacitance as the input capacitor. This IC provides an under voltage lockout (UVLO) function to enhance the stability when startup.

### Power Sequence

Please refer to the below Figure 2. The recommended power-on sequence is that the PWM/VIN ready before EN ready. If not, the soft-start function will be disabled. As to power off sequence, the EN must be pulled low before PWM/VIN turning low.

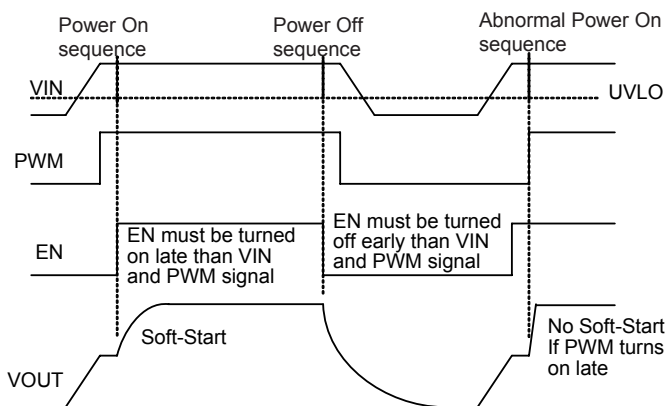

Figure 2. Power On Sequence Control by EN

### Soft-Start

The RT8562B employs a soft-start feature to limit the inrush current. The soft-start circuit prevents the excessive inrush current and input voltage droop. The soft-start time is determined by capacitor C<sub>SS</sub> connected to SS pin with 5µA constant current to charge C<sub>SS</sub>. The value of capacitor C<sub>SS</sub> is user-defined to satisfy the designer's requirement.

### LED connection

The RT8562B equips 8-CH LED drivers and each channel supports up to 10 LEDs. The 8 LED strings are connected from VOUT to pin 7, 8, 9, 10, 12, 13, 14, and 15 respectively. If one of the LED channel is not used, the LED pin should be opened directly.

### Setting and Regulation of LED current

The LED current can be calculated by the following equation :

$$I_{LED}(mA) = \frac{20 \times 4.75}{R_{SET}(k\Omega)}$$

Where, the R<sub>SET</sub> is the resistor between ISET pin and GND.

This setting is the reference for the LED current at CH1 to CH8 and represents the sensed LED current for each string. The DC/DC converter regulates the LED current according to the setting.

If V<sub>IN</sub> is close to V<sub>OUT</sub> and smaller than V<sub>OUT</sub>, the control loop may turn on the power switch with minimum on time and then skip cycles to maintain LED current regulation.

### Brightness Control

The RT8562B features the digital dimming control scheme. A very high contrast ratio true digital PWM dimming can be achieved by driving PWM pin with a PWM signal and the recommended PWM frequency is 100Hz to 10kHz.

Dimming frequency can be sufficiently adjusted from 100Hz to 30kHz. However, LED current cannot be 100% proportional to duty cycle especially for high frequency and low duty ratio because of physical limitation caused by inductor rising time. Please refer to Table 1 and Figure 3.

Table 1.

Dimming Frequency (Hz)	Duty (Min.)	Duty (Max.)
100 < f <sub>PWM</sub> ≤ 200	0.16%	100%
200 < f <sub>PWM</sub> ≤ 500	0.40%	100%
500 < f <sub>PWM</sub> ≤ 1k	0.80%	100%
1k < f <sub>PWM</sub> ≤ 2k	1.60%	100%
2k < f <sub>PWM</sub> ≤ 5k	4.00%	100%
5k < f <sub>PWM</sub> ≤ 10k	8.00%	100%
10k < f <sub>PWM</sub> ≤ 20k	16.00%	100%

Note : The minimum duty in Table 1 is based on the application circuit and does not consider the deviation of current linearity.

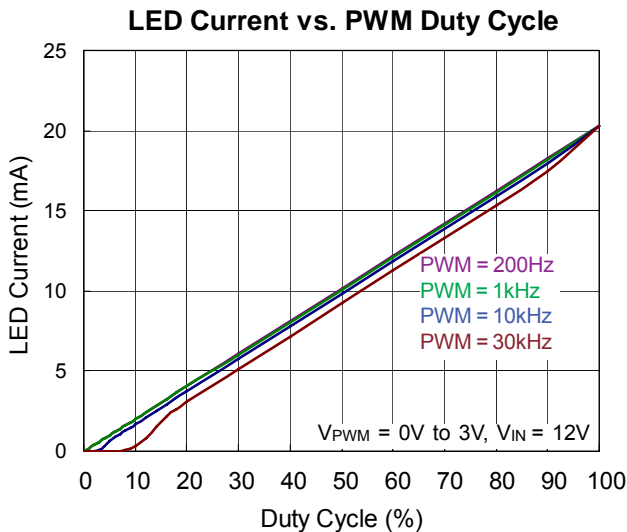

Figure 3. LED Current vs. PWM Dimming Duty Cycle

### Over Voltage Protection

The RT8562B equips over voltage protection (OVP) function. When the voltage at the OVP pin reaches a threshold of approximately 1.2V, the MOSFET driver output (LX1, LX2) will be turned "OFF". The MOSFET driver output (LX1, LX2) will be turned "ON" again once the voltage at OVP drops below the threshold voltage 1.2V.

So, the output voltage can be clamped at a certain voltage level and it can be calculated by the following equation :

$$V_{OUT, OVP} = V_{OVP} \times \left(1 + \frac{R2}{R3}\right)$$

Where

R2 and R3 are the voltage divider connected to OVP pin.

$V_{OVP}$  is typically 1.2V.

If at least one string is in normal operation, the controller will automatically ignore the open strings and continue to regulate the current for the string(s) in normal operation.

### Current Limit Protection

The RT8562B can limit the peak current to achieve over current protection. RT8562B senses the inductor current through LX1, LX2 pins in the switch-on period. The duty cycle depends on the current sense signal summing with the internal slope compensation compared to the COMP signal. The internal N-MOSFET will be turned off when the current signal is larger than the COMP signal. In the off period, the inductor current will descend. The internal MOSFET is turned on by the oscillator in the next beginning cycle.

### Over Temperature Protection

The RT8562B has over temperature protection (OTP) function to prevent the excessive power dissipation from overheating. The OTP will shut down switching operation while the junction temperature exceeds 150°C. Main converter starts switching when junction temperature cooling down approximately 20°C.

### Inductor Selection

The value of the output inductor (L), where the transition from discontinuous to continuous mode occurs is approximated by the following equation :

$$L = \frac{(V_{OUT} - V_{IN}) \times V_{IN}^2}{2 \times I_{OUT} \times f \times V_{OUT}^2}$$

Where,

$V_{OUT}$  = maximum output voltage.

$V_{IN}$  = minimum input voltage.

f = operating frequency.

$I_{OUT}$  = sum of current from all LED strings.

$\eta$  is the efficiency of the power converter.

The boost converter operates in discontinuous mode over the entire input voltage range when the L1 inductor value is less than this value L. With an inductance greater than L, the converter operates in continuous mode at the minimum input voltage and may be discontinuous at higher voltages.

The inductor must be selected with a saturation current rating greater than the peak current provided by the following equation :

$$I_{PEAK} = \frac{V_{OUT} \times I_{OUT}}{\eta \times V_{IN}} + \frac{V_{IN} \times T}{2 \times L} \left( \frac{V_{OUT} - V_{IN}}{V_{OUT}} \right)$$

### Diode Selection

Schottky diode is a good choice for an asynchronous Boost converter due to the small forward voltage. However, for power dissipation, reverse voltage rating and pulsating peak current are the important parameters of Schottky diode consideration. Choose a suitable diode whose reverse voltage rating is greater than the maximum output voltage.

**Capacitor Selection**

The input capacitor reduces current spikes from the input supply and minimizes noise injection to the converter. For most applications, a 10µF ceramic capacitor is sufficient. A value higher or lower may be used depending on the noise level from the input supply and the input current to the converter.

It is recommended to choose a ceramic capacitor bases on the output voltage ripple requirements. The minimum value of the output capacitor C<sub>OUT</sub> is approximately given by the following equation :

$$C_{OUT} = \frac{(V_{OUT} - V_{IN}) \times I_{OUT}}{\eta \times V_{RIPPLE} \times V_{OUT} \times f}$$

**Thermal Considerations**

For continuous operation, do not exceed absolute maximum junction temperature. The maximum power dissipation depends on the thermal resistance of the IC package, PCB layout, rate of surrounding airflow, and difference between junction and ambient temperature. The maximum power dissipation can be calculated by the following formula :

$$P_{D(MAX)} = \frac{T_{J(MAX)} - T_A}{\theta_{JA}}$$

Where T<sub>J(MAX)</sub> is the maximum junction temperature, T<sub>A</sub> is the ambient temperature, and θ<sub>JA</sub> is the junction to ambient thermal resistance.

For recommended operating condition specifications of RT8562B, the maximum junction temperature is 125°C and T<sub>A</sub> is the ambient temperature. The junction to ambient thermal resistance, θ<sub>JA</sub> is layout dependent. For WQFN-24L 4x4 packages, the thermal resistance, θ<sub>JA</sub> is 52°C/W on a standard JEDEC 51-7 four-layer thermal test board. The maximum power dissipation at T<sub>A</sub> = 25°C can be calculated by the following formula :

$$P_{D(MAX)} = \frac{125^{\circ}\text{C} - 25^{\circ}\text{C}}{52^{\circ}\text{C/W}} = 1.923\text{W}$$

for WQFN-24 4x4 package

The maximum power dissipation depends on the operating ambient temperature for fixed T<sub>J(MAX)</sub> and thermal resistance, θ<sub>JA</sub>. For RT8562B package, the derating curve in Figure 4 allows the designer to see the effect of rising ambient temperature on the maximum power dissipation.

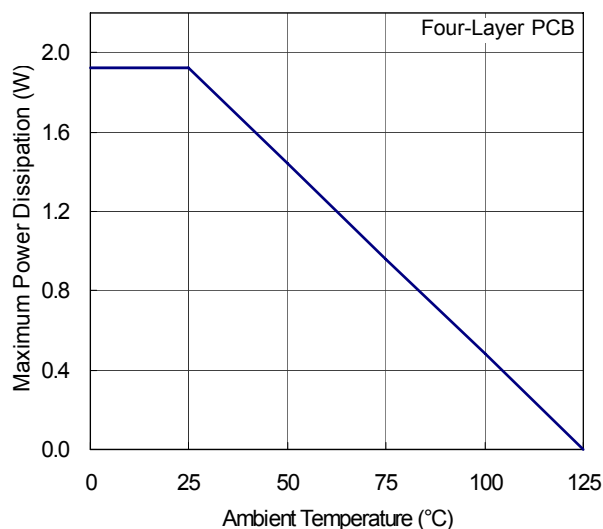

Figure 4. Derating Curve for RT8562B Package

**Layout Guideline**

PCB layout is very important to design power switching converter circuits. The following layout guide lines should be strictly followed for best performance of the RT8562B.

- ▶ The power components L, D1, C1, C<sub>OUT1</sub> and C<sub>OUT2</sub> must be placed as close as possible to reduce the ac current loop. The PCB trace between power components must be short and wide as possible due to large current flow through these trace during operation.
- ▶ Place L and D1 connected to LX pin as close as possible. The trace should be short and wide as possible.
- ▶ It is recommend to place C6 close to VIN pin.
- ▶ Pin22 is the compensation point to adjust system stability. Place the compensation components to pin22 as close as possible.

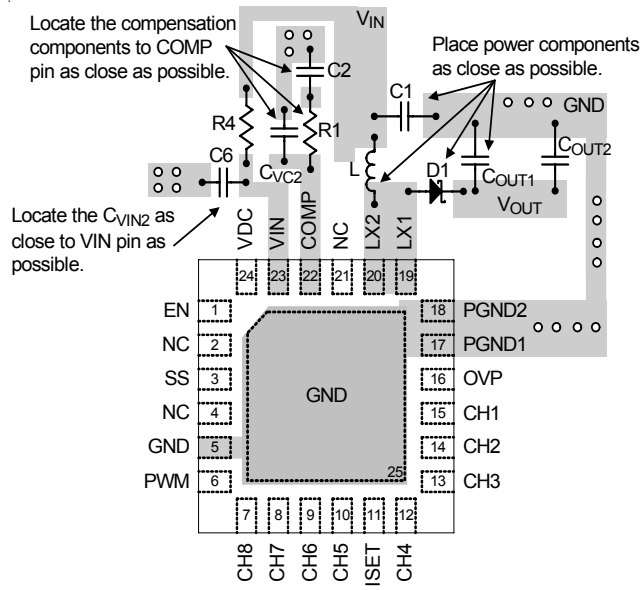
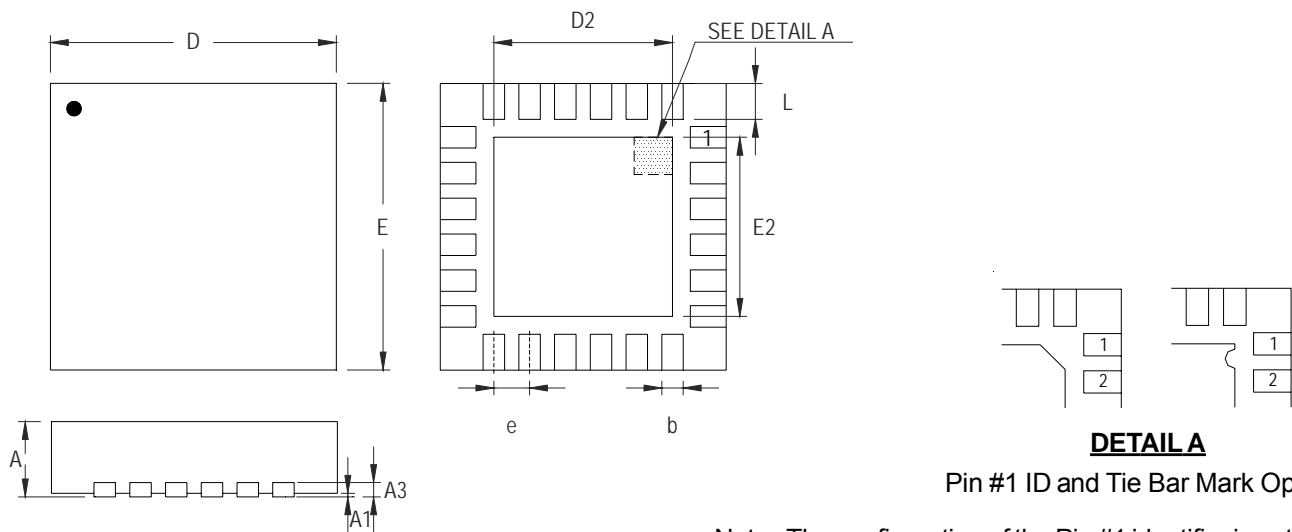

Figure 5

**Outline Dimension**



**DETAIL A**

Pin #1 ID and Tie Bar Mark Options

Note : The configuration of the Pin #1 identifier is optional, but must be located within the zone indicated.

Symbol	Dimensions In Millimeters		Dimensions In Inches	
	Min	Max	Min	Max
A	0.700	0.800	0.028	0.031
A1	0.000	0.050	0.000	0.002
A3	0.175	0.250	0.007	0.010
b	0.180	0.300	0.007	0.012
D	3.950	4.050	0.156	0.159
D2	2.300	2.750	0.091	0.108
E	3.950	4.050	0.156	0.159
E2	2.300	2.750	0.091	0.108
e	0.500		0.020	
L	0.350	0.450	0.014	0.018

**W-Type 24L QFN 4x4 Package**

**Richtek Technology Corporation**

Headquarter  
5F, No. 20, Taiyuen Street, Chupei City  
Hsinchu, Taiwan, R.O.C.  
Tel: (8863)5526789 Fax: (8863)5526611

**Richtek Technology Corporation**

Taipei Office (Marketing)  
5F, No. 95, Minchiuan Road, Hsintien City  
Taipei County, Taiwan, R.O.C.  
Tel: (8862)86672399 Fax: (8862)86672377  
Email: marketing@richtek.com

Information that is provided by Richtek Technology Corporation is believed to be accurate and reliable. Richtek reserves the right to make any change in circuit design, specification or other related things if necessary without notice at any time. No third party intellectual property infringement of the applications should be guaranteed by users when integrating Richtek products into any application. No legal responsibility for any said applications is assumed by Richtek.