

Cost-Effective, 1.8A Sink/Source Bus Termination Regulator

General Description

The RT9045A is a simple, cost-effective and high-speed linear regulator designed to generate termination voltage in Double Data Rate (DDR) memory system to comply with the devices requirements. The regulator is capable of actively sinking or sourcing up to 1.8A while regulating an output voltage to within 20mV. The output termination voltage can be tightly regulated to track $V_{DDQ} / 2$ by two external voltage divider resistors or the desired output voltage can be programmed by externally forcing the REFEN pin voltage.

The RT9045A also incorporates a high-speed differential amplifier to provide ultra-fast response in line/load transient. Other features include extremely low initial offset voltage, excellent load regulation, current limiting in bi-directions and on-chip thermal shutdown protection.

Ordering Information

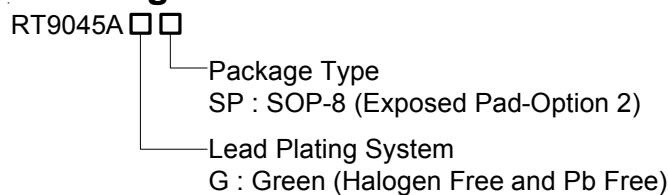

Note :

Richtek products are :

- ▶ RoHS compliant and compatible with the current requirements of IPC/JEDEC J-STD-020.
- ▶ Suitable for use in SnPb or Pb-free soldering processes.

Marking Information

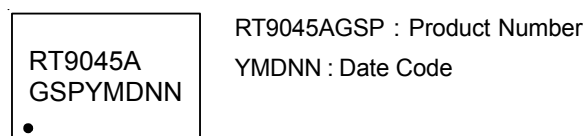

Features

- Ideal for DDR V_{TT} Applications
- Sink and Source Current :
 - ▶ DDRII 1.8A Sink/Source @ $V_{IN} = 1.8V$
 - ▶ DDRIII 1.5A Sink/Source @ $V_{IN} = 1.5V$
 - ▶ LPDDRIII 1.2A Sink/Source @ $V_{IN} = 1.35V$
 - ▶ DDRIV 1.2A Sink/Source @ $V_{IN} = 1.2V$
- Integrated Power MOSFETs
- Generate Termination Voltage for DDR Memory Interfaces
- Stable with Output Ceramic Capacitor
- High Accuracy Output Voltage at Full-Load
- Output Adjustment by Two External Resistors
- Low External Component Count
- Shutdown for Suspend to RAM (STR) Functionality with High Impedance Output
- Current Limiting Protection
- On-Chip Thermal Protection
- RoHS Compliant

Applications

- Desktop PCs, Notebooks, and Workstations
- Graphics Card Memory Termination
- Set Top Boxes, Digital TVs, Printers
- Embedded Systems
- Active Termination Buses
- DDR Memory Systems

Pin Configurations

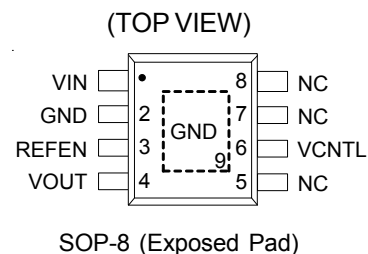

Typical Application Circuit

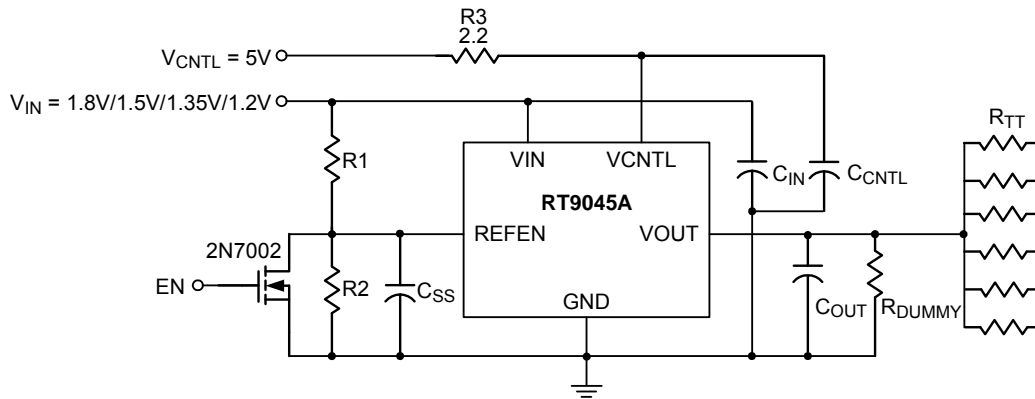

$R_1 = R_2 = 100k\Omega$, $R_{TT} = 50\Omega / 33\Omega / 25\Omega$
 $R_{DUMMY} = 1k\Omega$ as for V_{OUT} discharge when V_{IN} is not presented but V_{CNTL} is presented
 $C_{OUT} = 10\mu F$ (Ceramic) under the worst case testing condition
 $C_{IN} = 10\mu F$, $C_{CNTL} = 1\mu F$, $C_{SS} = 1nF$ to $0.1\mu F$

Test Circuit

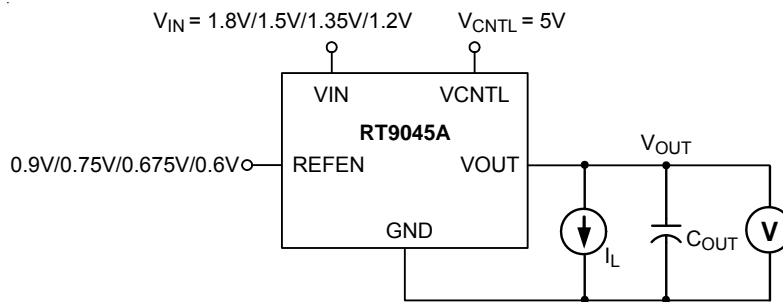

Figure 1. Output Voltage Tolerance, ΔV_{LOAD}

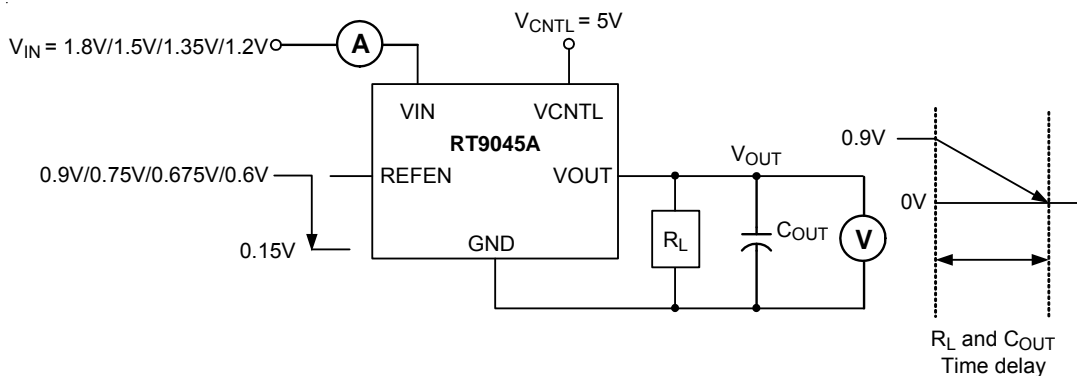

Figure 2. Current in Shutdown Mode, I_{STBY}

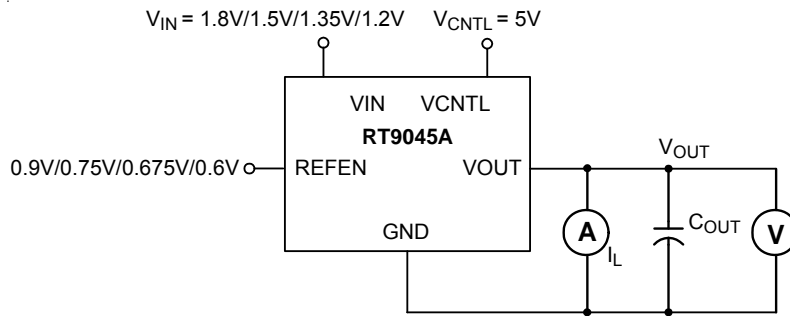

Figure 3. Current Limit for High Side, I_{LIM}

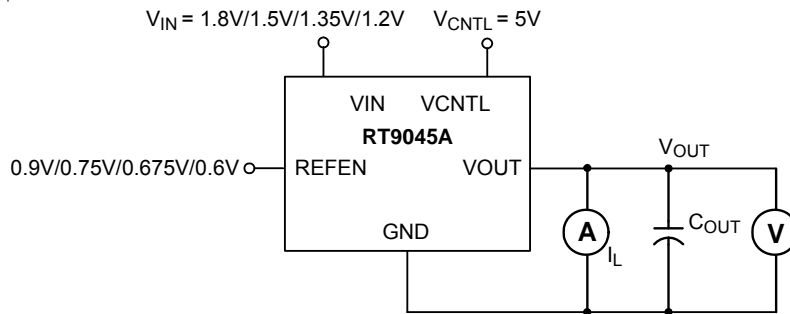

Figure 4. Current Limit for Low Side, I_{LIM}

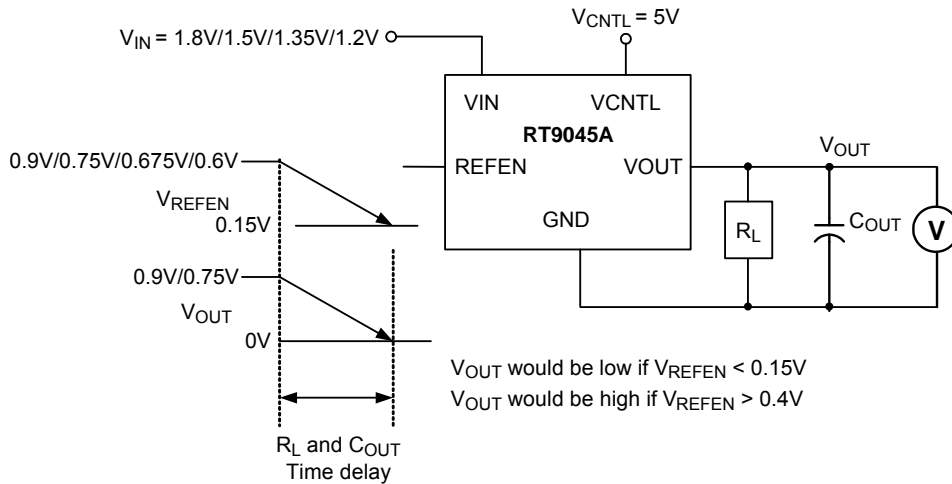
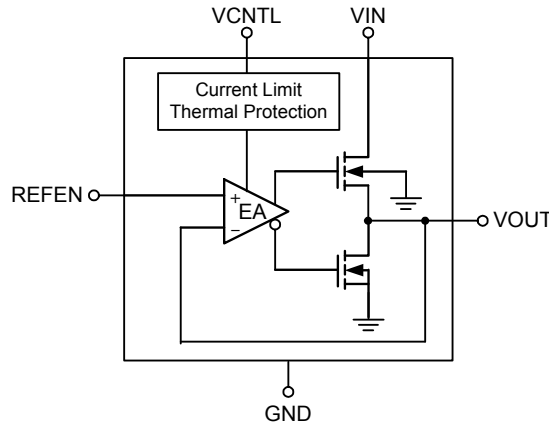

Figure 5. REFEN Pin Shutdown Threshold, V_{IH} & V_{IL}

Function Block Diagram



Functional Pin Description

VIN

Input voltage which supplies current to the output pin. Connect this pin to a well-decoupled supply voltage. To prevent the input rail from dropping during large load transient, a large, low ESR capacitor is recommended to use. The capacitor should be placed as close as possible to the VIN pin.

GND (Exposed Pad)

Common Ground. The exposed pad must be soldered to a large PCB and connected to GND for maximum power dissipation.

VCNTL

VCNTL supplies the internal control circuitry and provides the drive voltage. The driving capability of output current is proportioned to the VCNTL. Connect this pin to 5V bias supply to handle large output current with at least 1 μ F capacitor from this pin to GND. An important note is that VIN should be kept lower or equal to VCNTL.

REFEN

Reference voltage input and active low shutdown control pin. Two resistors dividing down the VIN voltage on this pin to create the regulated output voltage. Pulling this pin to ground turns off the device by an open-drain, such as 2N7002, signal N-MOSFET.

VOUT

Regulator output. VOUT is regulated to REFEN voltage that is used to terminate the bus resistors. It is capable of sinking and sourcing current while regulating the output rail. To maintain adequate large signal transient response, typical value of 10 μ F ceramic capacitors are recommended to reduce the effects of current transients on VOUT.

Absolute Maximum Ratings (Note 1)

- Input Voltage, V_{IN} ----- -0.3V to 6V
- Control Voltage, V_{CNTL} ----- -0.3V to 6V
- Reference Input Voltage, V_{REFEN} ----- -0.3V to 6V
- Output Voltage, V_{OUT} ----- -0.3V to 6V
- Power Dissipation, P_D @ $T_A = 25^\circ C$
 SOP-8 (Exposed Pad) ----- 3.44W
- Package Thermal Resistance (Note 2)
 SOP-8 (Exposed Pad), θ_{JA} ----- $29^\circ C/W$
 SOP-8 (Exposed Pad), θ_{JC} ----- $2^\circ C/W$
- Junction Temperature ----- $150^\circ C$
- Lead Temperature (Soldering, 10 sec.) ----- $260^\circ C$
- Storage Temperature Range ----- $-65^\circ C$ to $150^\circ C$
- ESD Susceptibility (Note 3)
 HBM (Human Body Model) ----- 2kV
 MM (Machine Model) ----- 200V

Recommended Operating Conditions (Note 4)

- Input Voltage, V_{IN} ----- 1V to 5.5V
- Control Voltage, V_{CNTL} ----- $5V \pm 5\%$
- Junction Temperature Range ----- $-40^\circ C$ to $125^\circ C$
- Ambient Temperature Range ----- $-40^\circ C$ to $85^\circ C$

Electrical Characteristics

($V_{IN} = 1.8V / 1.5V$, $V_{CNTL} = 5V$, $V_{REFEN} = 0.9V / 0.75V$, $C_{OUT} = 10\mu F$ (Ceramic), $T_A = 25^\circ C$, unless otherwise specified)

Parameter	Symbol	Test Conditions	Min	Typ	Max	Unit
Input						
VCNTL Operation Current	I_{CNTL}	$I_{OUT} = 0A$	--	0.7	2.5	mA
VCNTL Power on Reset	V_{POR}	VCNTL Rising	--	3.6	--	V
Standby Current (Note 5)	I_{STBY}	$V_{REFEN} < 0.2V$ (Shutdown), $R_{LOAD} = 180\Omega$	--	20	90	μA
Output						
Output Offset Voltage (Note 6)	V_{OS}	$I_{OUT} = 0A$	-13	--	13	mV
Load Regulation (Note 7)	ΔV_{LOAD}	$V_{IN} = 1.8V$, $V_{REFEN} = 0.9V$, $I_{OUT} = \pm 1.8A$	-13	--	13	mV
		$V_{IN} = 1.5V$, $V_{REFEN} = 0.75V$, $I_{OUT} = \pm 1.5A$				
		$V_{IN} = 1.35V$, $V_{REFEN} = 0.675V$, $I_{OUT} = \pm 1.2A$				
		$V_{IN} = 1.2V$, $V_{REFEN} = 0.6V$, $I_{OUT} = \pm 1.2A$				
Start Up						
Soft-Start Time	T_{SS}	From REFEN pin High to V_{OUT} ready $V_{REFEN} = 0.6V$, $C_{OUT} = 10\mu F$, No Load	--	--	30	μs

Parameter		Symbol	Test Conditions	Min	Typ	Max	Unit
Protection							
Current Limit	Source	$I_{LIMITsr}$	$V_{IN} = 1.8V, V_{REFEN} = 0.9V$	1.8	--	3.5	A
			$V_{IN} = 1.5V, V_{REFEN} = 0.75V$				
	Sink	$I_{LIMITsk}$	$V_{IN} = 1.8V, V_{REFEN} = 0.9V$	1.8	--	3.5	A
			$V_{IN} = 1.5V, V_{REFEN} = 0.75V$				
Short Circuit Current			$V_{IN} = 1.8V / 1.5V / 1.35V / 1.2V, V_{OUT} < 0.2V$	--	1.5	--	A
Thermal Shutdown Temperature		T_{SD}	$V_{CNTL} = 5V$	125	170	--	°C
Thermal Shutdown Hysteresis		ΔT_{SD}	$V_{CNTL} = 5V$	--	35	--	°C
Short Circuit Current			$V_{IN} = 1.8V / 1.5V / 1.35V / 1.2V, V_{OUT} < 0.2V$	--	1.5	--	A
Thermal Shutdown Temperature		T_{SD}	$V_{CNTL} = 5V$	125	170	--	°C
Thermal Shutdown Hysteresis		ΔT_{SD}	$V_{CNTL} = 5V$	--	35	--	°C
REFEN Shutdown							
Shutdown Threshold		V_{IH}	Enable	0.4	--	--	V
		V_{IL}	Shutdown	--	--	0.15	

Note 1. Stresses beyond those listed “Absolute Maximum Ratings” may cause permanent damage to the device. These are stress ratings only, and functional operation of the device at these or any other conditions beyond those indicated in the operational sections of the specifications is not implied. Exposure to absolute maximum rating conditions may affect device reliability.

Note 2. θ_{JA} is measured in the natural convection at $T_A = 25^\circ C$ on a high effective thermal conductivity test board (4 Layers, 2S2P) of JEDEC 51-7 thermal measurement standard. The case point of θ_{JC} is on the exposed pad for package.

Note 3. Devices are ESD sensitive. Handling precaution is recommended.

Note 4. The device is not guaranteed to function outside its operating conditions.

Note 5. Standby current is the input current drawn by a regulator when the output voltage is disabled by a shutdown signal on REFEN pin ($V_{IL} < 0.15V$). It is measured with $V_{IN} = 1.8V, V_{CNTL} = 5V$.

Note 6. V_{OS} offset is the voltage measurement defined as V_{OUT} subtracted from V_{REFEN} .

Note 7. Regulation is measured at constant junction temperature by using a 5ms current pulse. Devices are tested for load regulation in the load range from 0A to 1.8A peak.

Typical Operating Characteristics

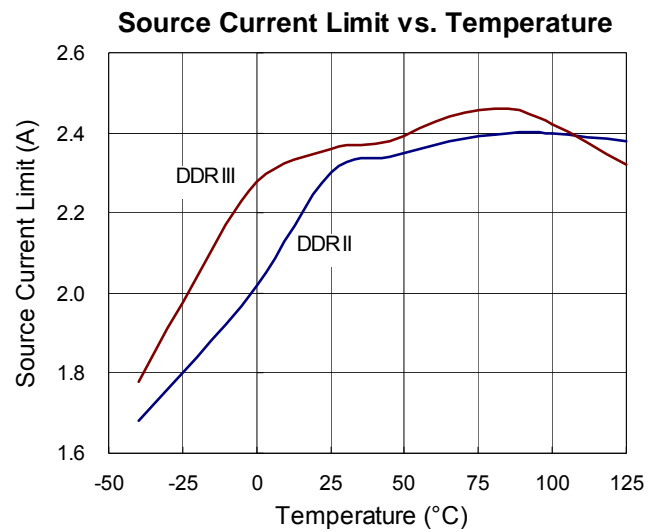
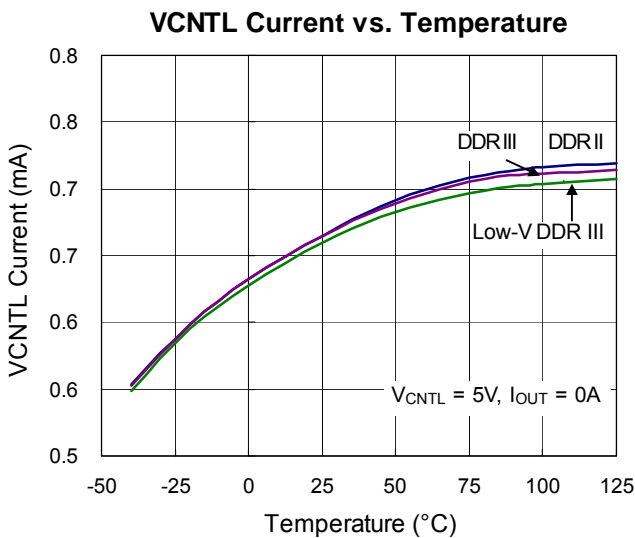
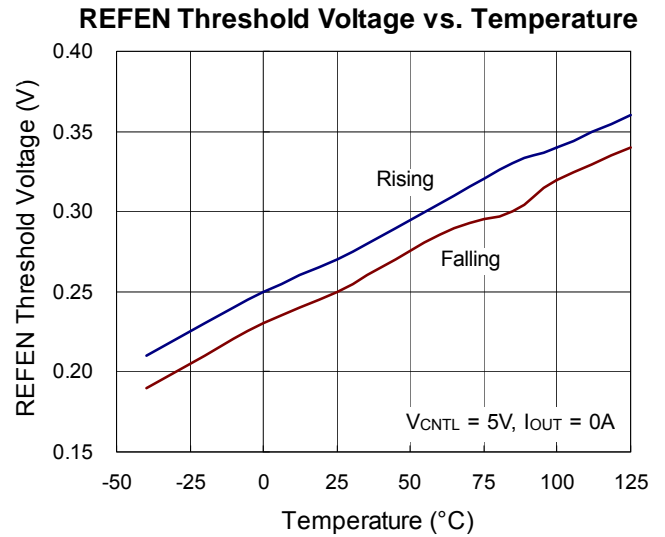
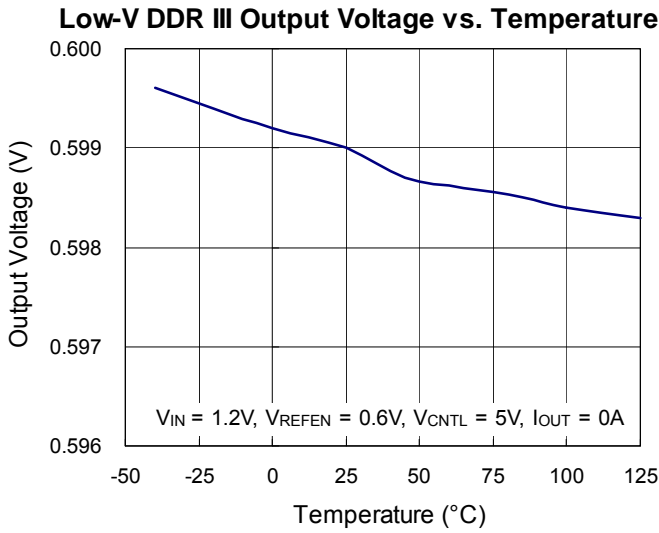
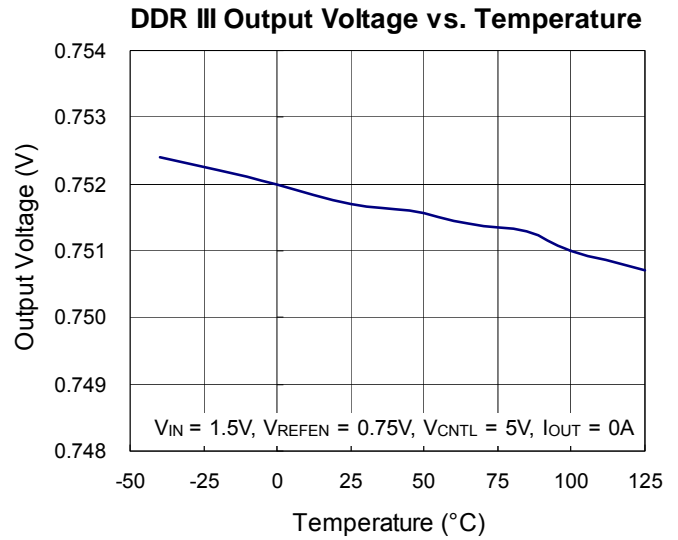
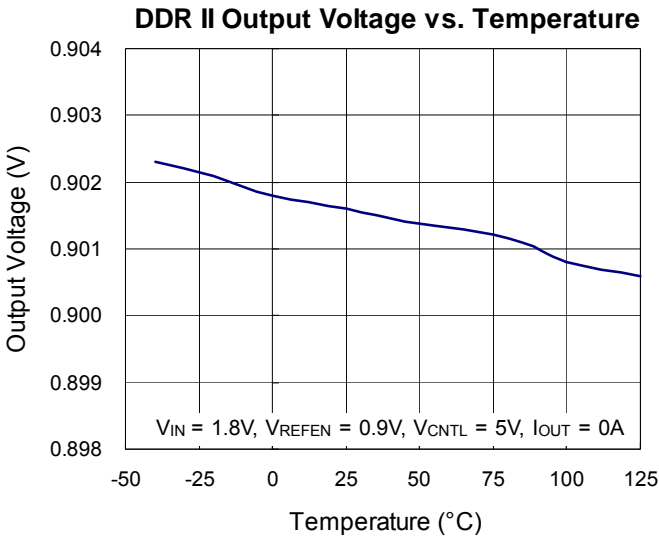

Sink Current Limit vs. Temperature

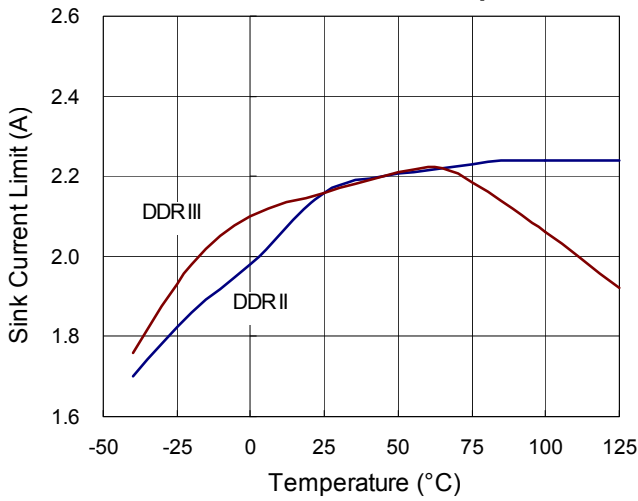

0.9V_{TT} @ 1.8A Transient Response

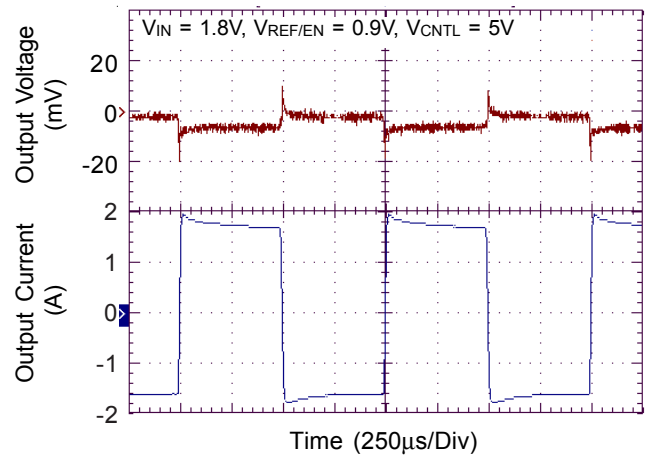

0.75V_{TT} @ 1.5A Transient Response

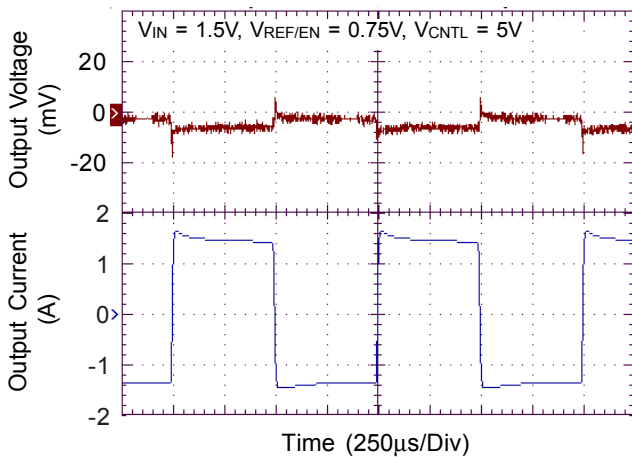

0.6V_{TT} @ 1.2A Transient Response

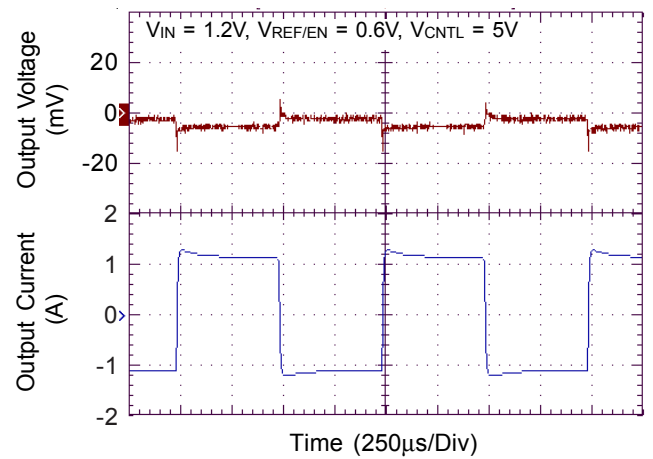

Application Information

Output Voltage Setting

The RT9045A is a high-speed linear regulator designed to generate termination voltage in Double Data Rate (DDR) memory system. Besides, the RT9045A could also serves as a general linear regulator. The RT9045A accepts an external reference voltage at the REFEN pin and provides an output voltage regulated to this reference voltage level as shown in Figure 6, where

$$V_{OUT} = V_{IN} \times R2 / (R1 + R2)$$

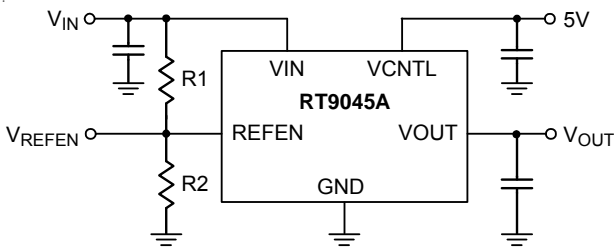

Figure 6. RT9045A Operating as a Linear Regulator

General Regulator

Like other linear regulator, dropout voltage and thermal issue should be specially considered. Figure 7 shows the $R_{DS(ON)}$ vs. Temperature curve of RT9045A. The minimum dropout voltage could be obtained by the product of $R_{DS(ON)}$ and output current. For thermal consideration, please refer to the relative section.

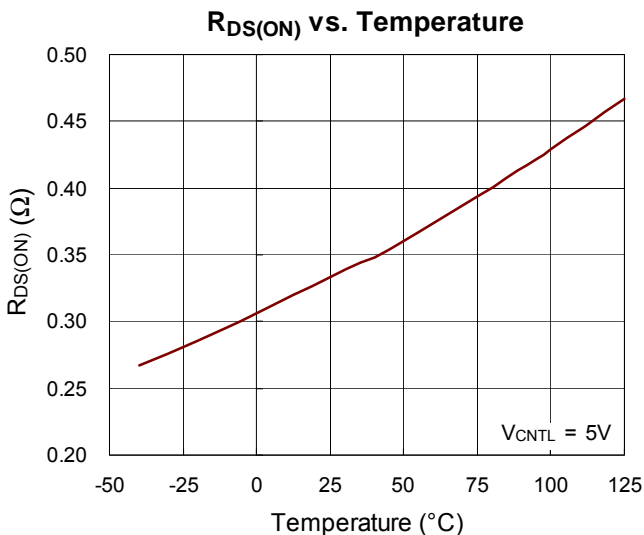

Figure 7. $R_{DS(ON)}$ vs. Temperature

Shutdown Control

Refer to the "Typical Application Circuit". Make sure the current sinking capability of pull-down N-MOSFET is enough for the chosen voltage divider to pull-down the voltage at REFEN pin below 0.15V to shutdown the device.

In addition, the capacitor C_{SS} and voltage divider form the low-pass filter.

Soft-Start

The RT9045A builds in an internal soft-start circuit to prevent inrush current during start-up. The internal soft-start time depends on REFEN voltage. For DDRIV application (REFEN = 0.6V), The soft-start time is within 30μs.

Current Limit & Short Circuit Protection

The RT9045A implements the current limit and output short protection circuit against the unexpected applications. The current limit circuit monitors and controls the pass transistor's gate voltage, providing the load current up to at least 1.8A. If the load current exceeds the current limit trip point, RT9045A will soon reduce the load current to around 1.5A constantly, refer to Figure 8.

If the output voltage is abruptly pulled down to less than 0.2V, the short circuit protection is triggered and then maintains the load current at 1.5A. It prevents RT9045A from being damaged in case an output short to ground event occurs.

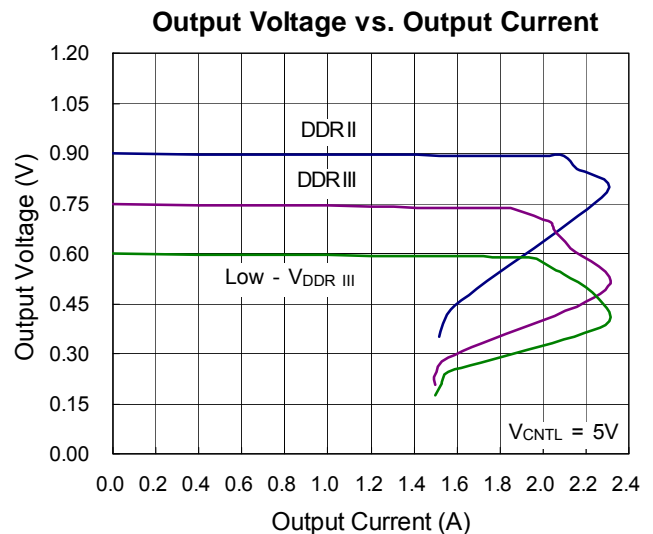

Figure 8. Output Voltage vs. Output Current

Input Capacitor and Layout Consideration

Place the input bypass capacitor as close as possible to the RT9045A. A low ESR capacitor larger than 20μF is recommended for the input capacitor. Use short and wide traces to minimize parasitic resistance and inductance. Inappropriate layout may result in large parasitic inductance and cause undesired oscillation between the RT9045A and the proceeding power converter.

Thermal Considerations

For continuous operation, do not exceed absolute maximum junction temperature. The maximum power dissipation depends on the thermal resistance of the IC package, PCB layout, rate of surrounding airflow, and difference between junction and ambient temperature. The maximum power dissipation can be calculated by the following formula :

$$P_{D(MAX)} = (T_{J(MAX)} - T_A) / \theta_{JA}$$

where $T_{J(MAX)}$ is the maximum junction temperature, T_A is the ambient temperature, and θ_{JA} is the junction to ambient thermal resistance.

For recommended operating condition specifications, the maximum junction temperature is 125°C. The junction to ambient thermal resistance, θ_{JA} , is layout dependent.

For SOP-8 (Exposed Pad) packages, the thermal resistance, θ_{JA} , is 29°C/W on a standard JEDEC 51-7 four-layer thermal test board.

The maximum power dissipation at $T_A = 25^\circ\text{C}$ can be calculated by the following formula :

$$P_{D(MAX)} = (125^\circ\text{C} - 25^\circ\text{C}) / (29^\circ\text{C/W}) = 3.44\text{W for SOP-8 (Exposed Pad) package}$$

The maximum power dissipation depends on the operating ambient temperature for fixed $T_{J(MAX)}$ and thermal resistance, θ_{JA} . The derating curve in Figure 9 allows the designer to see the effect of rising ambient temperature on the maximum power dissipation.

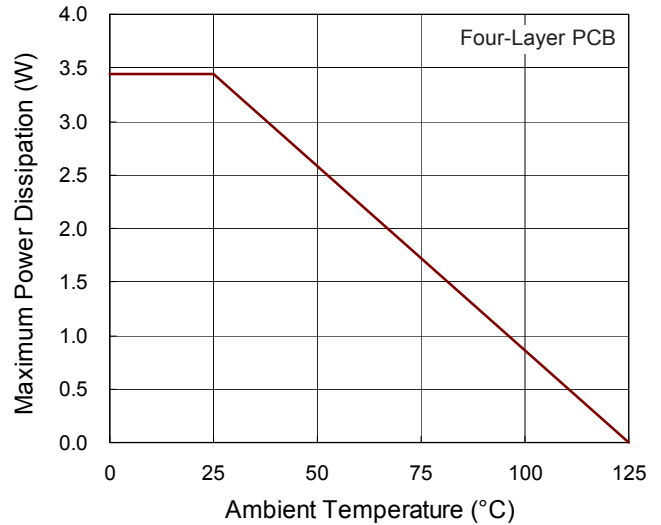
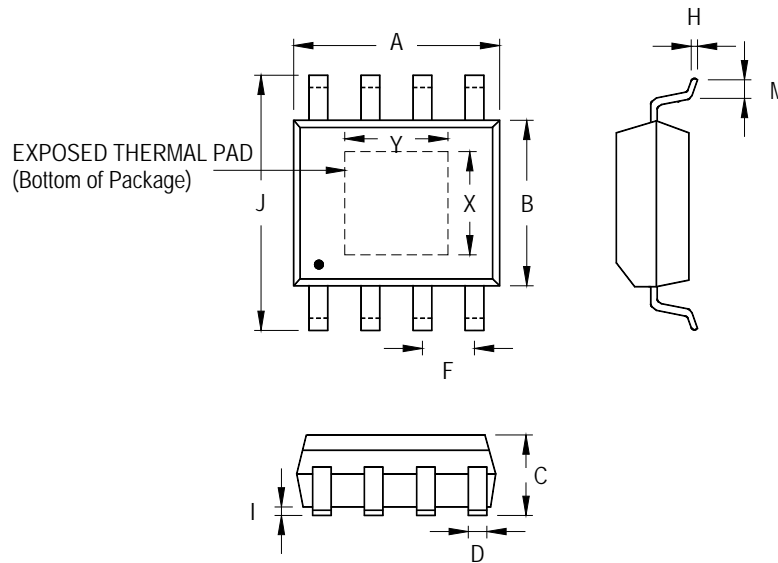

Figure 9. Derating Curve of Maximum Power Dissipation

Outline Dimension



Symbol	Dimensions In Millimeters		Dimensions In Inches		
	Min	Max	Min	Max	
A	4.700	5.100	0.185	0.200	
B	3.800	4.000	0.150	0.157	
C	1.346	1.753	0.053	0.069	
D	0.330	0.510	0.013	0.020	
F	1.194	1.346	0.047	0.053	
H	0.170	0.254	0.007	0.010	
I	0.000	0.152	0.000	0.006	
J	5.790	6.200	0.228	0.244	
M	0.400	1.270	0.016	0.050	
Option 1	X	2.000	2.300	0.079	0.091
	Y	2.000	2.300	0.079	0.091
Option 2	X	2.100	2.513	0.083	0.099
	Y	3.000	3.500	0.118	0.138

8-Lead SOP (Exposed Pad) Plastic Package

Richtek Technology Corporation

14F, No. 8, Tai Yuen 1st Street, Chupei City
 Hsinchu, Taiwan, R.O.C.
 Tel: (8863)5526789

Richtek products are sold by description only. Richtek reserves the right to change the circuitry and/or specifications without notice at any time. Customers should obtain the latest relevant information and data sheets before placing orders and should verify that such information is current and complete. Richtek cannot assume responsibility for use of any circuitry other than circuitry entirely embodied in a Richtek product. Information furnished by Richtek is believed to be accurate and reliable. However, no responsibility is assumed by Richtek or its subsidiaries for its use; nor for any infringements of patents or other rights of third parties which may result from its use. No license is granted by implication or otherwise under any patent or patent rights of Richtek or its subsidiaries.