

Switch-Mode Single Cell Li-ion Battery Charger with USB OTG

General Description

The RT9451 integrates a high efficiency USB friendly switch mode charger with On-The-Go (OTG) support for single cell Li-ion and Li-polymer batteries, D+D- detection, and a 50mA LDO regulator into a single chip.

The charger features a synchronous 375kHz PWM controller with integrated power MOSFETs, input current sensing and regulation, Minimum Input Voltage Regulation (MIVR), high accuracy charge current and voltage regulation, and charge termination. It charges the battery in three phases : low current pre-charge, constant current fast charge, and constant voltage trickle charge. The input current is automatically limited to the value set by the host. The charger can be configured to terminate charge based on user-selectable minimum current level and automatically restart the charge cycle if the battery voltage falls below the recharge threshold. A safety timer with reset control provides a safety backup for I²C interface. The charger automatically enters sleep mode or high impedance mode when the input supply is removed. The charge status is reported to the host using the I²C interface and the STAT pin. The D+D- detection circuit allows automatic detection of a USB wall charger. If a wall charger is detected, the input current limit will automatically increase from 500mA to 975mA.

In OTG mode, the PWM controller boosts the battery voltage to 5V and provides up to 1.6A of current to the USB output. At very light load, the Boost operates in burst mode to optimize efficiency. OTG mode can be enabled either through I²C interface or GPIO control.

Applications

- Mobile Phones and Smart Phones
- MP3 Players
- Handheld Devices

Ordering Information

RT9451 □ □

- Package Type
QW : WQFN-32L 4x4 (W-Type)
- Lead Plating System
G : Green (Halogen Free and Pb Free)

Note :

Richtek products are :

- ▶ RoHS compliant and compatible with the current requirements of IPC/JEDEC J-STD-020.
- ▶ Suitable for use in SnPb or Pb-free soldering processes.

Simplified Application Circuit

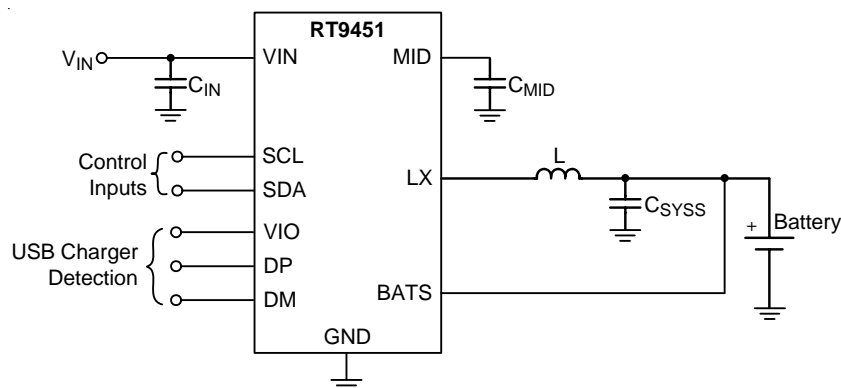

Features

- Integrated Switching Charger and 50mA LDO in a Single Package
- Charges Faster Than Linear Chargers
- High Accuracy Voltage and Current Regulation
 - Charge Voltage Regulation Accuracy : $\pm 1\%$
 - Charge Current Regulation Accuracy : $\pm 5\%$
- Minimum Input Voltage Regulation : 4.2V to 4.76V with Step of 80mV
- Bad Adaptor Detection and Rejection
- Safety Limit Register for Maximum Charge Voltage and Current Limiting
- High Efficiency Mini-USB/AC Battery Charger for Single Cell Li-Ion and Li-Polymer Battery Packs
- 28V Absolute Maximum Input Voltage Rating
- 12V Maximum Operating Input Voltage
- Built-In Input Current Sensing and Limiting
- Integrated Power FETs for Up to 4A Charge Rate
- Programmable Charge Parameters through I²C Interface (up to 400 Kbps) :
 - Input Current
 - Fast Charge/Termination Current
 - Charge Voltage (3.5V to 4.44V)
 - Safety Timer
 - Termination Enable
- Synchronous Fixed Frequency PWM Controller Operating at 375kHz With 0% to 99% Duty Cycle
- Automatic High Impedance Mode for Low Power Consumption
- Safety Timer with Reset Control
- Thermal Regulation and Protection
- Input/Output Over-Voltage Protections
- Status Output for Charging and Faults
- USB Friendly Boot-Up Sequence
- Automatic Charging
- Boost Mode Operation for USB OTG
 - Input Voltage Range (BATS) : 2.5V to 4.5V
 - Output Voltage for VIN : 4.425V to 5.506V
- RoHS Compliant and Halogen Free

Marking Information

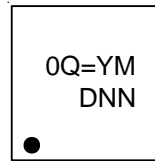

0Q= : Product Code
 YMDNN : Date Code

Pin Configurations

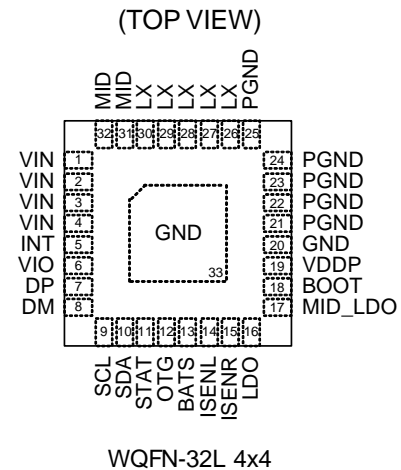

Functional Pin Description

Pin No.	Pin Name	Pin Function
1 to 4	VIN	Power Input. Bypass to PGND with a 10 μ F ceramic capacitor. It also provides power to the load in boost mode.
5	INT	Interrupt Pin (Open-Drain). This pin is pulled low when a fault occurs.
6	VIO	I/O Reference Voltage. A VIO level above 0.6V disables automatic D+/D- detection.
7	DP	USB Port D+ Input Connection.
8	DM	USB Port D- Input Connection.
9	SCL	I ² C Interface Clock Input. Open-drain output, connect a 10k Ω pull-up resistor.
10	SDA	I ² C Interface Data Input. Open-drain output, connect a 10k Ω pull-up resistor.
11	STAT	Charge Status Indicator. Pull low when charge is in progress. Open-drain for other conditions. This pin can also be controlled through I ² C register. The STAT can be used to drive a LED or communicate with a host processor.
12	OTG	Boost Mode Enable Control. Boost mode is turned on whenever this pin is active. Polarity is user defined through I ² C register. The pin is disabled by default and can be enabled through I ² C register bit.
13	BATS	Auxiliary Power Supply. Connect to the battery pack to provide power in high impedance mode. Bypass to GND with a 1 μ F ceramic capacitor.
14	ISENL	Charge Current Sense Input. Battery current is sensed via the voltage drop across an external sense resistor. A 0.1 μ F ceramic capacitor to PGND is required.
15	ISENR	Battery Voltage and Current Sense Input. Bypass to PGND with a ceramic capacitor (minimum 0.1 μ F) if there are long inductive leads to battery.
16	LDO	LDO Output. LDO is regulated to 4.9V and drives 60mA of current. Bypass LDO to GND with a minimum 1 μ F ceramic capacitor. LDO is enabled when VIN is above the VIN UVLO threshold.
17	MID_LDO	LDO Input Voltage. Please connect to MID.
18	BOOT	Bootstrap Supply for High-Side Gate Driver. Connect a 100nF ceramic capacitor (voltage rating above 10V) from BOOT pin to LX pin.
19	VDDP	Internal Bias Regulator Voltage for Driver. Connect a 1 μ F ceramic capacitor from this output to PGND. External loads on VDDP is not allowed.
20, 33 (Exposed Pad)	GND	Pure Ground. The exposed pad must be soldered to a large PCB and connected to GND for maximum thermal dissipation.
21 to 25	PGND	Power Ground.
26 to 30	LX	Switch Node.
31, 32	MID	Connection Point Between Reverse Blocking MOSFET and High-Side MOSFET. Bypass to PGND with a minimum of 10 μ F capacitor. No other circuits are recommended to connect at MID pin.

Function Block Diagram

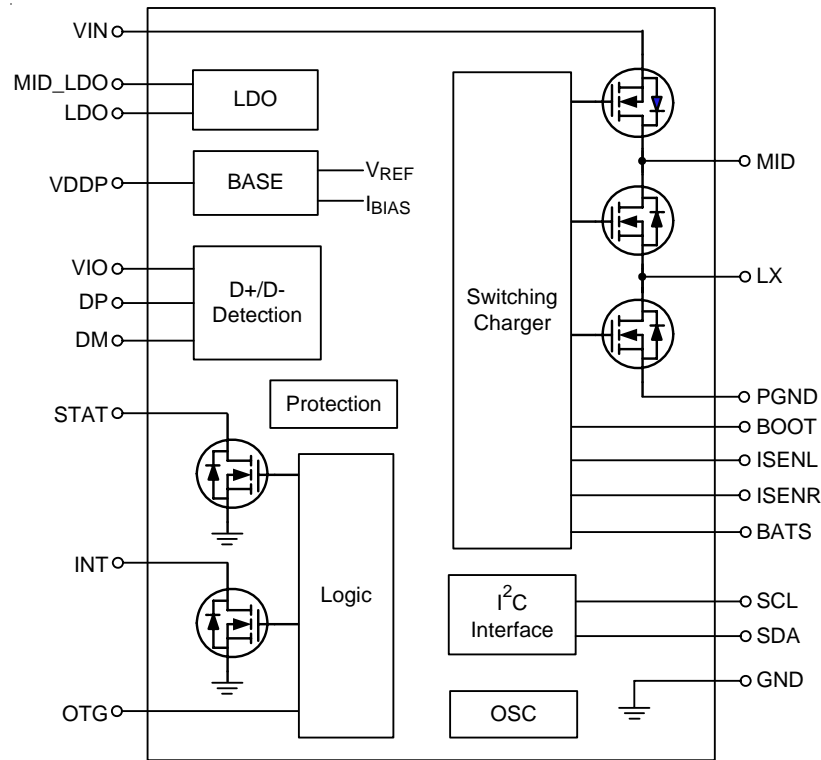

Operation

The RT9451 is designed for single cell Li-Ion battery charger in portable applications.

Base Circuits

Base circuits provide the internal power, VDD and reference voltage and bias current.

Protection Circuits

The protection circuits include the OVP, UVLO and OTP circuits. The protection circuits turn off the charging when the input power or die temperature is in abnormal level.

Switching Charger

The switching charger controls the operation during the charging process. The controller will make sure the battery is well charged in a suitable current, voltage, and die temperature.

Logic Circuits

The STAT and INT indicate the charger and interrupt condition. During the charging process, the STAT pin is

pulled low and pulled high when the charger is under abnormal condition or charge done. The INT pin indicates the fault condition. When any fault occurs, the INT is pulled low.

LDO

The RT9451 provides a 50mA LDO to support the peripheral circuits. The output voltage is regulated to 4.9V and the maximum output current is 120mA.

OSC

The oscillator runs at fixed 375kHz frequency for the PWM control of switching charger.

I²C Interface

The I²C interface is used to program battery voltage, charge current, termination current, MIVR level, and OTG voltage.

D+/D- Detection

The D+/D- detection can detect the devices which are inserted to the USB connector.

Absolute Maximum Ratings (Note 1)

- Supply Voltage V_{IN} ----- -0.3V to 28V
- MID, BOOT to PGND ----- -0.3V to 28V
- Other Pins ----- -0.3V to 6V
- V_{ISENL} to V_{ISENR} ----- $\pm 6V$
- Output Current (average) LX ----- 4A
- Output Current (continuous) LDO ----- 100mA
- Power Dissipation, P_D @ $T_A = 25^\circ C$
- WQFN-32L 4x4 ----- 3.59W
- Package Thermal Resistance (Note 2)
- WQFN-32L 4x4, θ_{JA} ----- $27.8^\circ C/W$
- WQFN-32L 4x4, θ_{JC} ----- $7^\circ C/W$
- Junction Temperature ----- $150^\circ C$
- Lead Temperature (Soldering, 10 sec.) ----- $260^\circ C$
- Storage Temperature Range ----- $-65^\circ C$ to $150^\circ C$
- ESD Susceptibility (Note 3)
- HBM (Human Body Model) ----- 2kV
- MM (Machine Model) ----- 200V

Recommended Operating Conditions (Note 4)

- Supply Input Voltage Range, V_{IN} ----- 4.3V to 12V
- Junction Temperature Range ----- $-40^\circ C$ to $125^\circ C$
- Ambient Temperature Range ----- $-40^\circ C$ to $85^\circ C$

Electrical Characteristics

($V_{BATS} = 3.6V \pm 5\%$, $T_A = 25^\circ C$, unless otherwise specified)

Parameter	Symbol	Test Conditions	Min	Typ	Max	Unit
Input Currents						
Battery Discharge Current in High Impedance Mode (ISENL, ISENR, LX, BATS Pins)	$I_{DISCHARGE}$	$V_{BATS} = 4.2 V$	High Impedance Mode, SDA = SCL = 0	--	2	30 μA
VIN Supply Current	I_Q	$V_{IN} > V_{IN(MIN)}$	Charger PWM ON	--	10000	-- μA
			Charger PWM OFF	--	--	5000 μA
Voltage Regulation						
Output Charge Voltage	V_{OREG}	Operating in voltage regulation, programmable		3.5	--	4.44 V
Voltage Regulation Accuracy		0 to $85^\circ C$		-1	--	1 %

Parameter	Symbol	Test Conditions	Min	Typ	Max	Unit
Current Regulation Fast Charge						
Output Charge Current	I _{CHRG}	V _{SHORT} ≤ V _{BATS} < V _{OREG} V _{IN} > 5V, R _{SENSE} = 20mΩ, LOW_CHG = 0, Programmable	1000	--	4000	mA
		V _{BATS} < V _{OREG} , V _{IN} > 5V, R _{SENSE} = 20mΩ, LOW_CHG = 1	--	150	--	
Charge Termination Detection						
Termination Charge Current	I _{EOC}	V _{BATS} > V _{OREG} - V _{RECH} , V _{IN} > 5V, R _{SENSE} = 20mΩ, Programmable	50	--	400	mA
Deglitch Time for Charge Termination		Both Rising and Falling, 2mV Overdrive, t _{RISE} , t _{FALL} = 100ns	--	43	--	μs
Charge Current Accuracy						
Offset Voltage, Sense Voltage Amplifier		V _{SHORT} ≤ V _{BATS} < V _{OREG} V _{IN} > 5V, R _{SENSE} = 20mΩ, LOW_CHG = 0, Programmable	-1	--	1	mV
BAD Adaptor Detection						
Input Voltage Lower Limit	V _{IN(MIN)}	Bad adaptor detection, V _{IN} falling	3.5	3.7	3.9	V
Deglitch Time for V _{IN} Rising above V _{IN(MIN)}		Rising voltage, 2mV over drive, t _{RISE} = 100ns	--	30	--	ms
Hysteresis for V _{IN(MIN)}	ΔV _{IN(MIN)}	V _{IN} Rising	100	--	200	mV
Current Source to GND		During bad adaptor detection	20	30	40	mA
Detection Interval	T _{INT}	Input power source detection	--	2	--	s
Minimum Input Voltage Regulation						
Minimum Input Voltage Regulation Threshold	V _{MIVR}	Charge Mode, Programmable	4.2	--	4.76	V
V _{MIVR} Accuracy			-2	--	2	%
Active Input Current Regulation						
AICR		AICR = 100mA	80	90	100	mA
		AICR = 500mA	400	450	500	
VDDP Regulator						
Internal Bias Regulator Voltage	V _{DDP}	V _{IN} > V _{IN(min)} or V _{BATS} > V _{BATMIN} , I _{VDDP} = 1mA, C _{VDDP} = 1μF	2	--	6	V
VDDP Output Short Current Limit			--	60	--	mA
Voltage from BOOT to LX Pin		During charge or boost operation	--	--	6	V
Battery Recharge Threshold						
Recharge Threshold Voltage	V _{RECH}	Below V _{OREG}	100	130	160	mV
Deglitch Time		V _{BATS} decreasing below threshold, t _{FALL} = 100ns, 10mV overdrive	--	130	--	ms

Parameter	Symbol	Test Conditions	Min	Typ	Max	Unit	
Stat Output							
Low Level Output Saturation Voltage		$I_O = 10\text{mA}$, Sink Current	--	--	0.4	V	
High Level Leakage Current		Voltage on STAT pin is 5V	--	--	1	μA	
Reverse Protection Comparator							
Reverse Protection Threshold, $V_{IN} - V_{BATS}$	V_{SLP}	$2.3\text{V} \leq V_{BATS} \leq V_{OREG}$, VIN Falling	0	40	100	mV	
Reverse Protection Exit Hysteresis	$V_{SLP-EXIT}$	$2.3\text{V} \leq V_{BATS} \leq V_{OREG}$	40	100	200	mV	
Deglitch Time for VIN Rising above $V_{SLP} + V_{SLP-EXIT}$		Rising Voltage	--	30	--	ms	
VIN UVLO							
Under-Voltage Lockout Threshold	V_{UVLO}	VIN Rising	3.05	3.3	3.55	V	
Under-Voltage Lockout Threshold Hysteresis	ΔV_{UVLO}	VIN falling from above V_{UVLO}	120	150	--	mV	
PWM							
Internal N-MOSFET On-Resistance	High-Side	R_{DSON_UG}	AICR = None, from VIN to LX		--	80	m Ω
	Low-Side	R_{DSON_LG}	from LX to PGND		--	60	
Maximum Duty Cycle		D_{MAX}	--	99.5	--	%	
Minimum Duty Cycle		D_{MIN}	0	--	--	%	
Boost Mode Operation for VIN							
Boost Output Voltage Accuracy		$2.5\text{V} < V_{IN} < 4.5\text{V}$; Including line and load regulation over full temp range	-5	--	5	%	
Maximum Output Current for Boost		$V_{IN_B} = 5\text{V}$, $2.5\text{V} < V_{BATS} < 4.5\text{V}$	1600	--	--	mA	
Cycle-by-Cycle Current Limit for Boost		$V_{IN_B} = 5\text{V}$, $2.5\text{V} < V_{BATS} < 4.5\text{V}$	4	6	8	A	
Over-Voltage Protection Threshold for Boost (VIN Pin)	V_{IN_BOVP}	Threshold over VIN to turn off converter during boost	5.6	6	6.3	V	
Over-Voltage Protection Hysteresis	ΔV_{IN_BOVP}	VIN falling from above V_{IN_BOVP}	--	200	--	mV	
Maximum Battery Voltage for Boost	V_{BATMAX}	V_{BATS} rising edge during boost	4.5	4.75	5	V	
Maximum Battery Voltage Hysteresis	ΔV_{BATMAX}	V_{BATS} falling from above V_{BATMAX}	--	200	--	mV	
Minimum Battery Voltage for Boost (BATS pin)	V_{BATMIN}	During Boosting	--	2.5	--	V	
		Before boost Starts	--	2.9	3.05		

Parameter	Symbol	Test Conditions	Min	Typ	Max	Unit
Charger Protection						
Input V_{IN} Threshold Voltage	V_{IN_OVP}	Threshold over V_{IN} to turn off converter during charge	11	12	13	V
V_{IN} Hysteresis		V_{IN} falling from above V_{IN_OVP}	--	140	--	mV
Battery OVP Threshold Voltage	V_{OVP_BATS}	V_{BATS} threshold over V_{OREG} to turn off charger during charge (% V_{OREG})	110	117	121	%
OVP Hysteresis	ΔV_{OVP_BATS}	Lower limit for V_{BATS} falling from > V_{OVP} (% V_{OREG})	--	11	--	%
Cycle-by-Cycle Current Limit for Charge	I_{LIMIT}	Charge Mode Operation	5	7	9	A
Trickle to Fast Charge Threshold	V_{SHORT}	V_{BATS} rising, V_{SHORT} connected to V_{DDP}	1.9	2.1	2.2	V
V_{SHORT} Hysteresis	ΔV_{SHORT}	V_{BATS} falling from above V_{SHORT}	--	100	--	mV
Trickle Charge Charging Current	I_{SHORT}	$V_{BATS} \leq V_{SHORT}$	70	80	90	mA
Thermal Regulation Threshold		Charge current begins to taper down	--	120	--	°C
Time Constant for the 32-Second Timer	T_{32S}	32 Second Mode	--	32	--	s
LDO						
LDO Output Voltage	V_{LDO}	$V_{IN} = 5.5V$	4.8	4.9	5	V
PSRR		$f = 100Hz, C_{LDO} = 1\mu F$	--	60	--	dB
Maximum LDO Output Current	I_{LDO}		60	--	--	mA
Dropout Voltage	V_{DO}	$V_{IN} = 4.5V, I_{LDO} = 50mA$	--	100	250	mV
D+ / D- Detection						
D+ Voltage Source	V_{DP_SCR}		0.5	0.6	0.7	V
D+ Voltage Source Output Current			250	--	--	μA
D- Current Sink	I_{DM_SINK}		50	100	150	μA
Input Capacitance	C_I	DM Pin, Switch Open	--	4.5	5	pF
		DP Pin, Switch Open	--	4.5	5	
Input Leakage	I_I	DM Pin, Switch Open	-1	--	1	μA
		DP Pin, Switch Open	-1	--	1	
DP Low Comparator Threshold	V_{DP_LOW}		0.8	--	--	V
DM High Comparator Threshold	V_{DM_HIGH}		0.8	--	--	V
DM Low Comparator Threshold	V_{DM_LOW}		--	--	475	mV
Logic Levels and Timing Characteristics (SCL, SDA, INT)						
Output Low Threshold Level	V_{OL}	$I_O = 3mA$, Sink Current (SDA, INT)	--	--	0.4	V
Input Low Threshold Level			--	--	0.4	V

Parameter	Symbol	Test Conditions	Min	Typ	Max	Unit
Input High Threshold Level			1.2	--	--	V
Input Bias Current (SCL, SDA, INT)	$I_{(bias)}$	$V_{IO} = 1.8V$	--	--	1	μA
SCL Clock Frequency	f_{SCL}		--	--	400	kHz
Oscillator						
Oscillator Frequency	f_{OSC}		--	375	--	kHz
Frequency Accuracy			-10	--	10	%
Thermal Shutdown						
Thermal Shutdown Threshold	T_{SD}		--	165	--	$^{\circ}C$
Thermal Shutdown Hysteresis	ΔT_{SD}		--	10	--	$^{\circ}C$

Note 1. Stresses beyond those listed “Absolute Maximum Ratings” may cause permanent damage to the device. These are stress ratings only, and functional operation of the device at these or any other conditions beyond those indicated in the operational sections of the specifications is not implied. Exposure to absolute maximum rating conditions may affect device reliability.

Note 2. θ_{JA} is measured at $T_A = 25^{\circ}C$ on a high effective thermal conductivity four-layer test board per JEDEC 51-7. θ_{JC} is measured at the exposed pad of the package.

Note 3. Devices are ESD sensitive. Handling precaution is recommended.

Note 4. The device is not guaranteed to function outside its operating conditions.

Typical Application Circuit

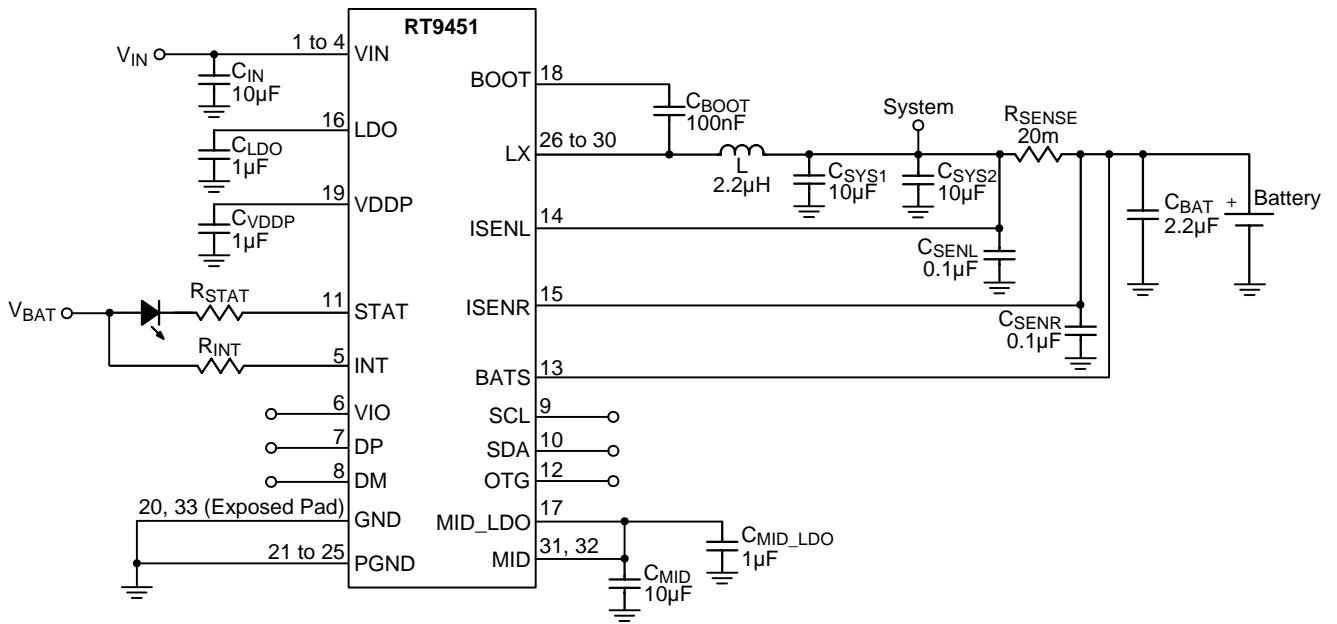

Typical Operating Characteristics
Charge Mode

Efficiency vs. Battery Voltage

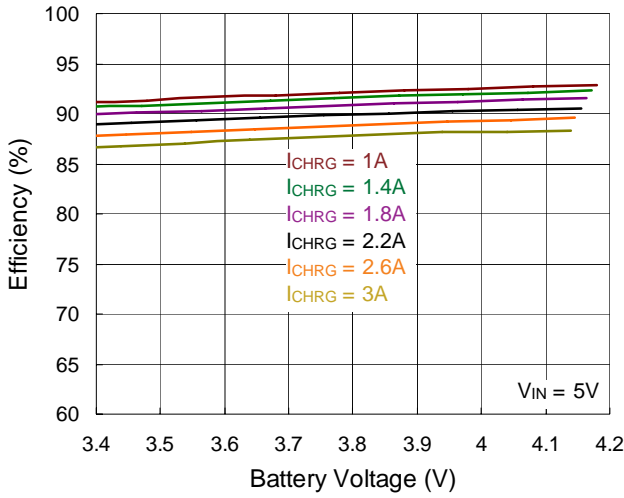

Efficiency vs. Battery Voltage

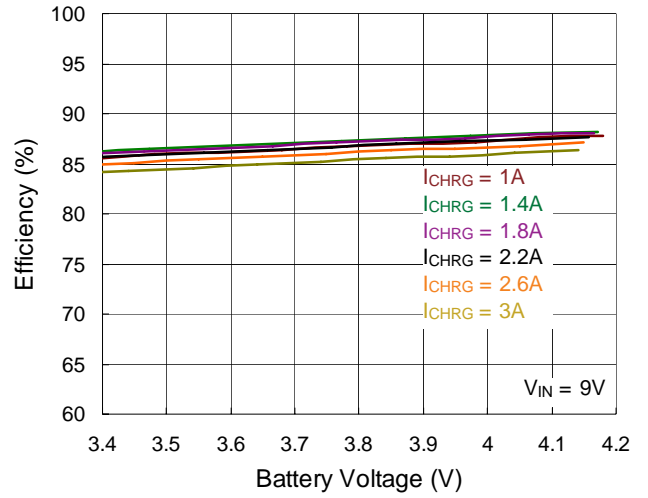

Adapter Insertion

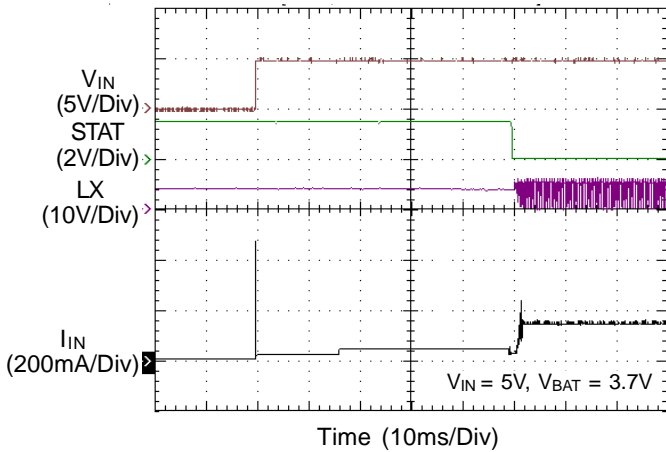

Battery Removal

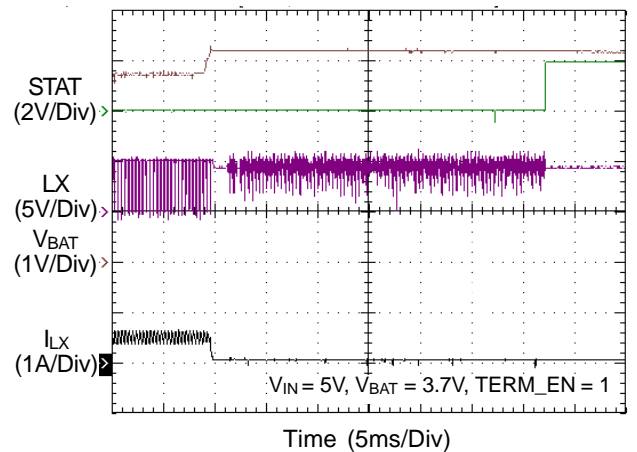

Bad Adapter

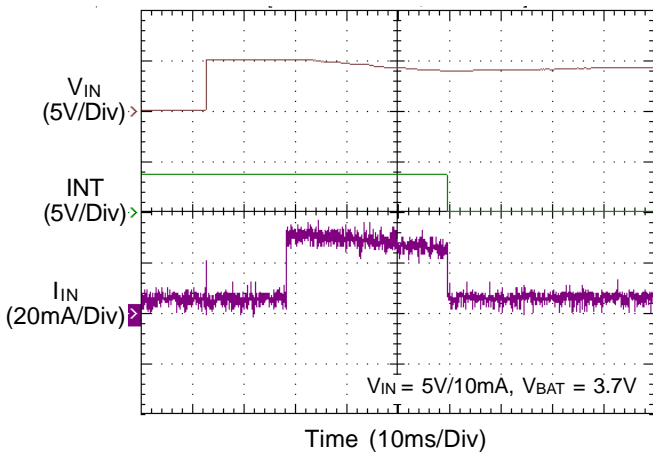

Minimum Input Voltage Regulation

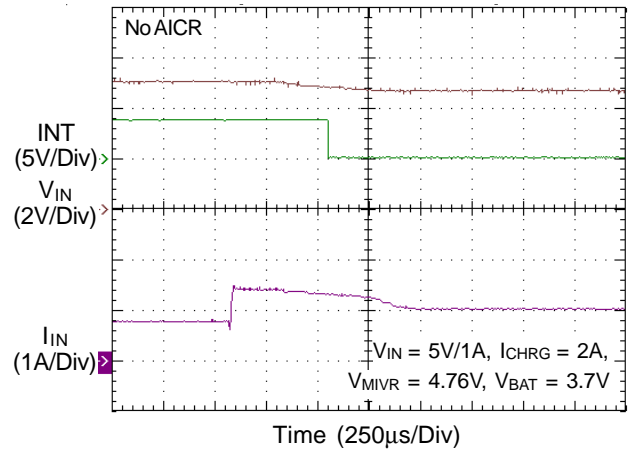

USB Charger Detection (DPDM Detection)

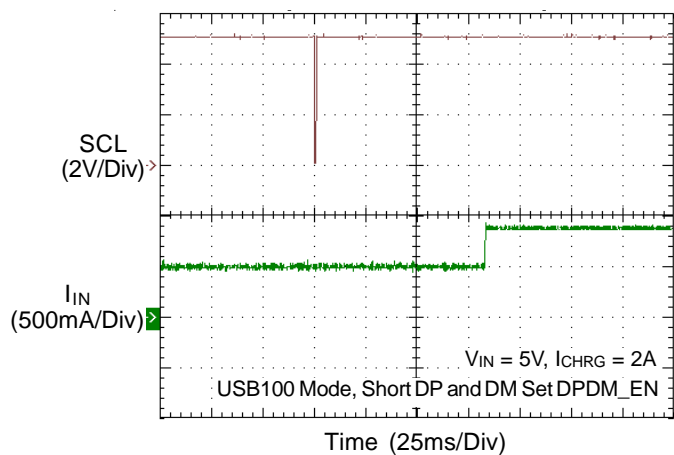

Boost Mode

Efficiency vs. Load Current

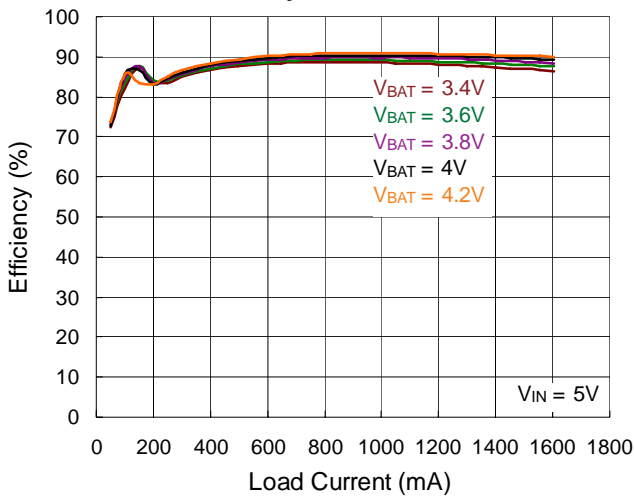

Line Regulation

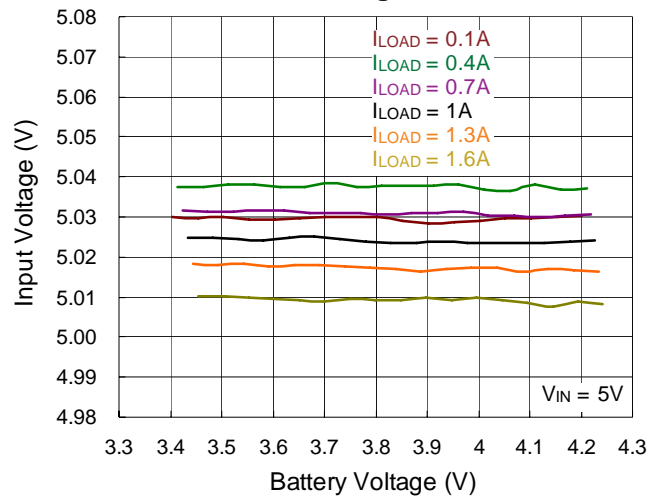

Load Regulation

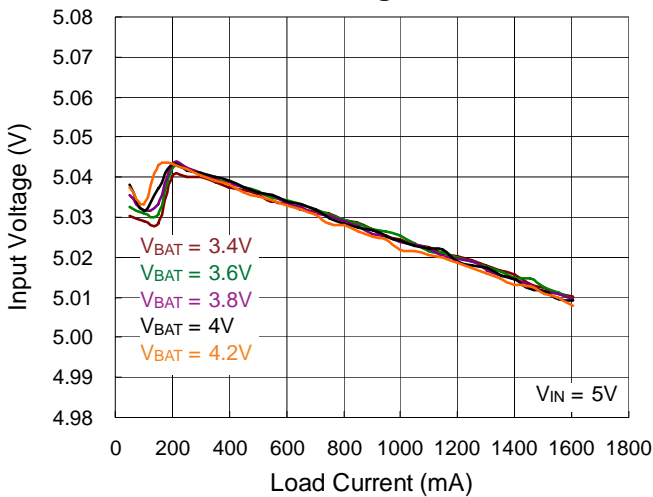

Battery Under-Voltage Protection

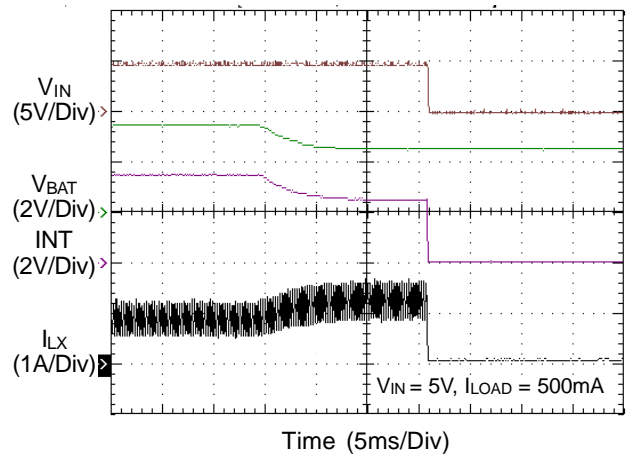

VIN Over-Voltage Protection

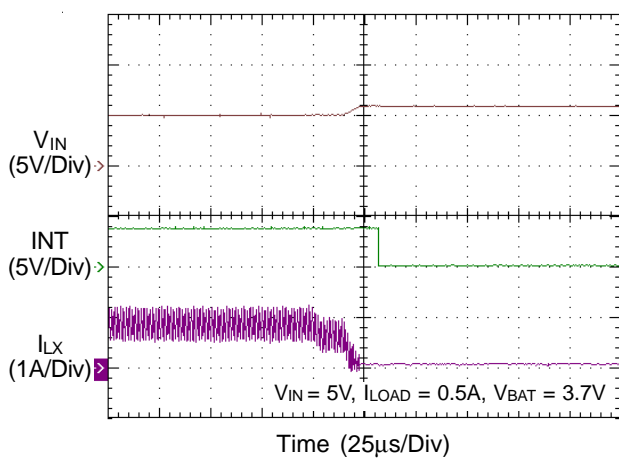

Load Transient Response

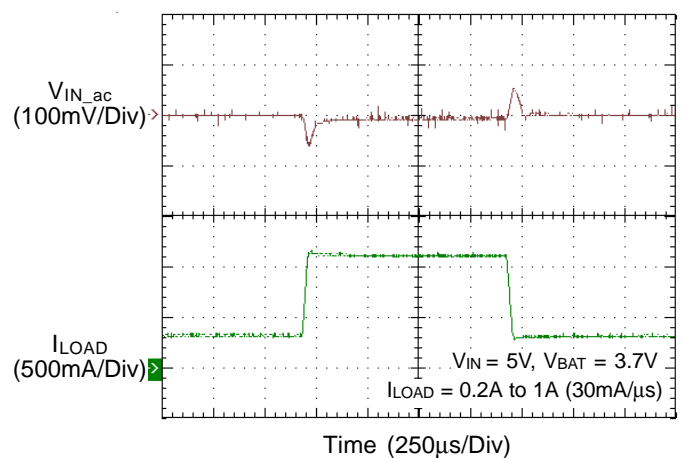

32-Second Safety Timer

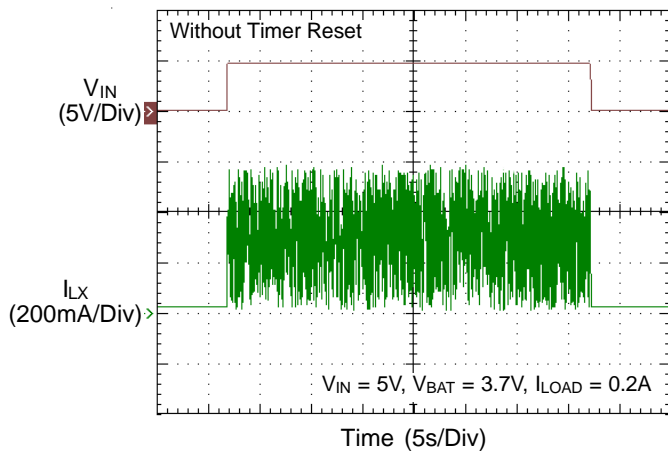

Application Information

The RT9451 is an integrated solution of single-cell Li-ion and Li-polymer battery charger for portable applications. The part integrates a synchronous PWM controller with power MOSFETs to provide MIVR (Minimum Input Voltage Regulation), input current sensing, high accuracy current and voltage regulation, and charge termination in a small package for space limited devices. The part also features USB OTG (On-The-Go) function and USB charger detection (DPDM detection) function.

The RT9451 provides three operation modes : charge mode, boost mode (USB OTG), and high impedance mode. In charge mode, the RT9451 supports a precision charging system for single cell. In boost mode, the RT9451 works as a Boost converter and boosts the voltage from battery to VIN pin for sourcing the OTG devices. In high impedance mode, the RT9451 stops charging or boosting and operates in a mode with low quiescent current from VIN or battery to reduce the power consumption when the portable device is in standby mode.

In charge mode, the RT9451 integrates USB charger detection for input current limit of 500mA and 1A. The detection is automatically triggered after each POR. The detection result can be ignored by the host via I²C interface. The slave address for the RT9451 is "1001010".

I²C Interface Timing Diagram

The RT9451 acts as an I²C -bus slave. The I²C-bus master configures the settings for charge mode and boost mode by sending command bytes to the RT9451 via the 2-wire I²C-bus. After the START condition, the I²C master sends a chip address. This address is seven bits long followed by an eighth bit which is a data direction bit (R/W). The second byte selects the register to which the data will be written. The third byte contains data to the selected register.

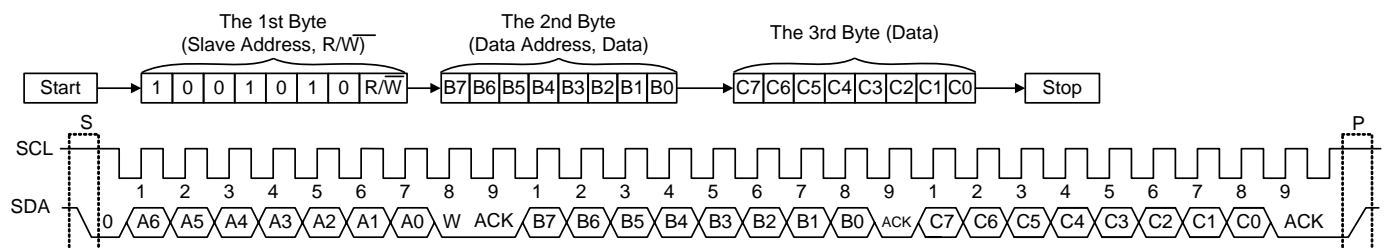

- S = Start Condition
- W = Write (SDA = "0")
- R = Read (SDA = "1")
- ACK = Acknowledge
- P = Stop Condition

I²C Information

Slave Address : 1001010

Table 1. Register Address Map

Register	Address (Hex)	Name	Default Value	Description
0	0	CONTROL	0000 1010	Enable control register
1	1	CONFIG_A	0000 0001	Charger current register
2	2	CONFIG_B	0001 1001	Charger voltage register
3	3	CONFIG_C	0000 0010	Special charger settings
4	4	CONFIG_D	0100 0000	Charger safety limits settings
6	6	STATUS_A	0000 0000	Status register A
7	7	STATUS_B	0000 0001	Status register B
8	8	INT1	0000 0000	Interrupt bits
9	9	INT2	0000 0000	Interrupt bits (charger)
10	0A	INT3	0000 0000	Interrupt bits (boost)
11	0B	MASK1	0000 0000	Interrupt masking bits
12	0C	MASK2	0000 0000	Interrupt masking bits
13	0D	MASK3	0000 0000	Interrupt masking bits
14	0E	CHIPID	0000 0001	Chip ID register

Control Register (Control)

Address - 0x00h

Data Bit	D7	D6	D5	D4	D3	D2	D1	D0
Field Name	STAT_EN [1:0]		Not Used	Not Used	LDO_EN	DPDM_EN	CH_EN [1:0]	
Read/Write	R/W	R/W	R/W	R/W	R/W	R/W	R/W	R/W
Reset Value	0	0	0	0	1	0	1	0

Field Name	Bit Definition
STAT_EN [1:0]	STAT enable bits 00 – AUTO (controlled by charger status) 01 – ON (low impedance) 10 – OFF (high impedance) 11 – not defined
LDO_EN	LDO enable bit 0 – Disabled 1 – Enabled
DPDM_EN	D+/D– detection enable 0 – Disabled 1 – Enabled Note : Bit is automatically reset after detection is completed.
CH_EN [1:0]	Charger enable bits 00 – Disabled / HiZ mode 01 – Boost mode 10 – Charge 11 – Charge with automatic recharge

Charger CONFIG Register A (CONFIG_A)

Address - 0x01h

Data Bit	D7	D6	D5	D4	D3	D2	D1	D0
Field Name	LMTSEL	VICHRG [3:0]				VITERM [2:0]		
Read/Write	R/W	R/W	R/W	R/W	R/W	R/W	R/W	R/W
Reset Value	0	0	0	0	0	0	0	1

Field Name	Bit Definition ⁽¹⁾
LMTSEL	Input current limit selection 0 – Input current limit is set to the higher of AICR [1:0] (CONFIG_B) and D+D– det. result 1 – AICR [1:0] (CONFIG_B) applied, D+D– detection result is ignored
VICHRG [3:0]	Charge current sense voltage (current equivalent for 20mΩ shunt) 0000 – 20mV (1000mA) 0001 – 24mV (1200mA) 0010 – 28mV (1400mA) 0011 – 32mV (1600mA) 0100 – 36mV (1800mA) 0101 – 40mV (2000mA) 0110 – 44mV (2200mA) 0111 – 48mV (2400mA) 1000 – 52mV (2600mA) 1001 – 56mV (2800mA) 1010 – 60mV (3000mA) 1011 – 64mV (3200mA) 1100 – 68mV (3400mA) 1101 – 72mV (3600mA) 1110 – 76mV (3800mA) 1111 – 80mV (4000mA)
VITERM [2:0]	Termination current sense voltage (current equivalent for 20mΩ shunt) 000 – 1mV (50mA) 001 – 2mV (100mA) 010 – 3mV (150mA) 011 – 4mV (200mA) 100 – 5mV (250mA) 101 – 6mV (300mA) 110 – 7mV (350mA) 111 – 8mV (400mA)

(1) During charging the lower value of VMCHRG [3:0] (CONFIG_D register) and VICHRG [2:0] applies.

Charger CONFIG Register B (CONFIG_B)

Address - 0x02h

Data Bit	D7	D6	D5	D4	D3	D2	D1	D0
Field Name	AICR [1:0]		VOREG [5:0]					
Read/Write	R/W	R/W	R/W	R/W	R/W	R/W	R/W	R/W
Reset Value	0	0	0	1	1	0	0	1

Field Name	Bit Definition ⁽¹⁾
AICR [1:0]	Input current limit setting 00 – 100mA 01 – 500mA 11 – No input current limit
VOREG [5:0]	Battery regulation voltage / boost output voltage 00 0000 – 3.50V / 4.425V 00 0001 – 3.52V / 4.448V 00 0011 – 3.56V / 4.471V ... 01 1000 – 3.98V / 4.977V 01 1001 – 4.00V / 5V 01 1010 – 4.02V / 5.023V ... 10 1111 – 4.44V / 5.506V ... 11 1111 – 4.44V / 5.506V

(1) During charging the lower value of VMCHRG [3:0] (CONFIG_D register) and VICHRG [5:0] applies.

Charger CONFIG Register C (CONFIG_C)

Address - 0x03h

Data Bit	D7	D6	D5	D4	D3	D2	D1	D0
Field Name	Not Used	OTG_PL	OTG_EN	TERM_EN	LOW_CHG	MIVR [2:0]		
Read/Write	R/W	R/W	R/W	R/W	R/W	R/W	R/W	R/W
Reset Value	0	0	0	0	0	0	1	0

Field Name	Bit Definition
OTG_PL	OTG pin polarity 0 – Active low 1 – Active high
OTG_EN	OTG pin enable 0 – Pin is disabled 1 – Pin is enabled
TERM_EN	Charge termination enable 0 – Disabled 1 – Enabled
LOW_CHG	Low charge current enable bit (current equivalent for 20mΩ shunt) 0 – Normal charge current sense voltage per register CONFIG_A 1 – 3mV (150mA)
MIVR [2:0]	Input voltage MIVR regulation voltage 000 – 4.20V 001 – 4.28V 010 – 4.36V 011 – 4.44V 100 – 4.52V 101 – 4.60V 110 – 4.68V 111 – 4.76V

Charger CONFIG Register D (CONFIG_D)

Address - 0x04h

Data Bit	D7	D6	D5	D4	D3	D2	D1	D0
Field Name	VMCHRG [3:0]				VMREG [3:0]			
Read/Write	R/W	R/W	R/W	R/W	R/W	R/W	R/W	R/W
Reset Value	0	1	0	0	0	0	0	0

Field Name	Bit Definition ⁽¹⁾
VMCHRG [3:0]	Maximum charge current sense voltage (current equivalent for 20mΩ shunt) 0000 – 20mV (1000mA) 0001 – 24mV (1200mA) 0010 – 28mV (1400mA) 0011 – 32mV (1600mA) 0100 – 36mV (1800mA) 0101 – 40mV (2000mA) 0110 – 44mV (2200mA) 0111 – 48mV (2400mA) 1000 – 52mV (2600mA) 1001 – 56mV (2800mA) 1010 – 60mV (3000mA) 1011 – 64mV (3200mA) 1100 – 68mV (3400mA) 1101 – 72mV (3600mA) 1110 – 76mV (3800mA) 1111 – 80mV (4000mA)
VMREG [3:0]	Maximum Battery Regulation Voltage / Maximum OTG Regulation Voltage 0000 – 4.20V / 5.230V 0001 – 4.22V / 5.253V 0010 – 4.24V / 5.276V ... 1100 – 4.44V / 5.506V ... 1111 – 4.44V / 5.506V

STATUS Register A (STATUS_A)

Address - 0x06h

Data Bit	D7	D6	D5	D4	D3	D2	D1	D0
Field Name	Not Used	STANDBY	Not Used	CHSTAT [2:0]			LDO	Not Used
Read/Write	R	R	R	R	R	R	R	R
Reset Value	0	0	0	0	0	0	0	0

Field Name	Bit Definition ⁽¹⁾
Not used	N/A
STANDBY	Standby status indicator 0 – Device is in ACTIVE mode 1 – Device is in STANDBY mode
Not used	N/A
CHSTAT [2:0]	Charger status bit 000 – High impedance mode or ready to charge 001 – Charge in progress (fast charge) 010 – Charge done 011 – Boost mode 100 – Charge in progress (pre charge) 101 – Not defined 110 – Not defined 111 – Not defined
LDO	LDO status bit 0 – LDO is disabled (OFF) 1 – LDO is enabled (ON), no fault
Not used	N/A

(1) Default values reflect state after Power On Reset, no charger plugged in, no faults present.

STATUS Register B (STATUS_B)

Address - 0x07h

Data Bit	D7	D6	D5	D4	D3	D2	D1	D0
Field Name	RESET	Not used	Not used	Not used	Not used	DPDM_D	DPDM_R	OTG
Read/Write	W	R	R	R	R	R	R	R
Reset Value	0	0	0	0	0	0	0	1

Field Name	Bit Definition ⁽¹⁾
RESET	Reset 0 – No effect 1 – Reset all parameters to default values Note : Read always returns “0”
Not used	N/A
Not used	N/A
Not used	N/A
Not used	N/A
DPDM_D	D+/D– detection done bit 0 – DPDM detection in progress or not started after initial power up reset 1 – DPDM detection is complete
DPDM_R	D+D– detection result 0 – Standard USB port (500mA current limit) 1 – USB charger (975mA current limit)
OTG	OTG pin status 0 – OTG pin at low level 1 – OTG pin at high level

(1) Default values reflect state after Power On Reset, no charger plugged in, no faults present, OTG pin high.

Interrupt Register 1 (INT1)

Address - 0x08h

Data Bit	D7	D6	D5	D4	D3	D2	D1	D0
Field Name	TSDI	VINOVPI	Not used	Not used	Not used	Not used	Not used	Not used
Read/Write	R	R	R	R/W	R/W	R/W	R/W	R
Reset Value	0	0	0	0	0	0	0	0

Field Name	Bit Definition
TSDI	Thermal shutdown fault. Set if die temperature exceeds thermal shutdown threshold. Reset when die temperature drops below TSD release threshold.
VINOVPI	VIN over-voltage protection. Set when $VIN > VIN_OVP$ is detected.
Not used	N/A
Not used	N/A
Not used	N/A
Not used	N/A
Not used	N/A
Not used	N/A

Interrupt Register 2 (INT2)

Address - 0x09h

Data Bit	D7	D6	D5	D4	D3	D2	D1	D0
Field Name	CHRVPI	CHBADI	CHBATOVI	CHTERMI	CHRCHGI	CH32MI	CHTREGI	CHMIVRI
Read/Write	R	R	R	R	R	R	R	R
Reset Value	0	0	0	0	0	0	0	0

Field Name	Bit Definition ⁽¹⁾
CHRVPI	Charger fault. Reverse protection ($VIN > V_{IN(MIN)}$ and $VIN < V_{BATS} + V_{SLP}$ (fault))
CHBADI	Charger fault. Bad adaptor ($VIN < V_{IN(MIN)}$ during power on detection)
CHBATOVI	Charger fault. Battery OVP
CHTERMI	Charge terminated
CHRCHGI	Recharge request ($V_{BATS} < V_{OREG} - V_{RECH}$)
CH32MI	Charger fault. 32 minutes time-out
CHTREGI	Charger warning. Thermal regulation loop active.
CHMIVRI	Charger warning. Input voltage MIVR loop active.

(1) All charger faults result in disabling the charger (CH_EN [1:0] = 00). Recharge request disables the charger only if CH_EN [1:0] = 10.

Interrupt Register 3 (INT3)

Address - 0x0Ah

Data Bit	D7	D6	D5	D4	D3	D2	D1	D0
Field Name	BSTVINOVI	BSTOLI	BSTLOWVI	BSTBATOVI	BST32SI	Not used	Not used	Not used
Read/Write	R	R	R	R	R	R	R	R
Reset Value	0	0	0	0	0	0	0	0

Field Name	Bit Definition ⁽¹⁾
BSTVINOVI	Boost fault. VIN OVP (VIN > VIN_BOVP)
BSTOLI	Boost fault. Over load.
BSTLOWVI	Boost fault. Battery voltage is too low.
BSTBATOVI	Boost fault. Battery over voltage.
BST32SI	Boost fault. 32s time-out fault.
Not used	N/A
Not used	N/A
Not used	N/A

(1) All charger faults result in disabling the charger (CH_EN [1:0] = 00).

Interrupt MASK Register 1 (MASK1)

Address - 0x0Bh

Data Bit	D7	D6	D5	D4	D3	D2	D1	D0
Field Name	TSDM	VINOVPM	Not used	Not used	Not used	Not used	Not used	Not used
Read/Write	R/W	R/W	R/W	R/W	R/W	R/W	R/W	R/W
Reset Value	0	0	0	0	0	0	0	0

Field Name	Bit Definition ⁽¹⁾
TSDM	TSD fault interrupt mask 0 – Interrupt not masked 1 – Interrupt masked
VINOVPM	VIN OVP fault interrupt mask 0 – Interrupt not masked 1 – Interrupt masked
Not used	N/A
Not used	N/A
Not used	N/A
Not used	N/A
Not used	N/A
Not used	N/A

(1) Setting any of the interrupt mask bits does not disable protection circuits. When set, the respective fault will not be signaled on the INT pin.

Interrupt MASK Register 2 (MASK2)

Address - 0x0Ch

Data Bit	D7	D6	D5	D4	D3	D2	D1	D0
Field Name	CHRVPM	CHBADM	CHBATOVM	CHTERMM	CHRCHGM	CH32MM	CHTREGM	CHMIVRM
Read/Write	R/W	R/W	R/W	R/W	R/W	R/W	R/W	R/W
Reset Value	0	0	0	0	0	0	0	0

Field Name	Bit Definition ⁽¹⁾
CHRVPM	Charger reverse protection interrupt mask 0 – Interrupt not masked 1 – Interrupt masked
CHBADM	Charger Bad adaptor interrupt mask 0 – Interrupt not masked 1 – Interrupt masked
CHBATOVM	Charger battery over voltage interrupt mask 0 – Interrupt not masked 1 – Interrupt masked
CHTERMM	Charge terminated interrupt mask 0 – Interrupt not masked 1 – Interrupt masked
CHRCHGM	Charger recharge request interrupt mask 0 – Interrupt not masked 1 – Interrupt masked
CH32MM	Charger 32m timeout interrupt mask 0 – Interrupt not masked 1 – Interrupt masked
CHTREGM	Charger thermal regulation loop active interrupt mask 0 – Interrupt not masked 1 – Interrupt masked
CHMIVRM	Charger input current MIVR active interrupt mask 0 – Interrupt not masked 1 – Interrupt masked

(1) Setting any of the interrupt mask bits does not disable protection circuits. When set, the respective fault will not be signaled on the INT pin.

Interrupt MASK Register 3 (MASK3)

Address - 0x0Dh

Data Bit	D7	D6	D5	D4	D3	D2	D1	D0
Field Name	BSTVINOVM	BSTOLM	BSTLOWVM	BSTBATOVM	BST32SM	Not used	Not used	Not used
Read/Write	R/W	R/W	R/W	R/W	R/W	R/W	R/W	R/W
Reset Value	0	0	0	0	0	0	0	0

Field Name	Bit Definition ⁽¹⁾
BSTVINOVM	Boost VIN over voltage interrupt mask 0 – Interrupt not masked 1 – Interrupt masked
BSTOLM	Boost over load interrupt mask 0 – Interrupt not masked 1 – Interrupt masked
BSTLOWVM	Boost low battery voltage interrupt mask 0 – Interrupt not masked 1 – Interrupt masked
BSTBATOVM	Boost battery over voltage interrupt mask 0 – Interrupt not masked 1 – Interrupt masked
BST32SM	Boost 32s time out interrupt mask 0 – Interrupt not masked 1 – Interrupt masked
Not used	N/A
Not used	N/A
Not used	N/A

(1) Setting any of the interrupt mask bits does not disable protection circuits. When set, the respective fault will not be signaled on the INT pin.

CHIP ID Register (CHIPID)

Address - 0x0Eh

Data Bit	D7	D6	D5	D4	D3	D2	D1	D0
Field Name	VENDOR_ID [3:0]				CHIP_REV [3:0]			
Read/Write	R	R	R	R	R	R	R	R
Reset Value	0	0	0	0	0	0	0	1

Charge Mode Operation

Minimum Input Voltage Regulation (MIVR)

The RT9451 features input voltage MIVR function to prevent input voltage drop due to insufficient current provided by the adaptor or USB input. If MIVR function is enabled, the input voltage decreases when the over current of the input power source occurs and is regulated at a predetermined voltage level which can be set from 4.20V to 4.76V with the step of 80mV by I²C interface to MIVR [2:0] in the register of address 0X03. The INT pin is pulled low to notify the host and the CHMIVR bit is set to high. At this time, the current drawn by the RT9451 equals to the maximum current value that the input power can provide at the predetermined voltage level, instead of the set value. And CHMIVR bit is set to "1" and INT pin is pulled low to notify the host. The MIVR function is initially set to 4.36V.

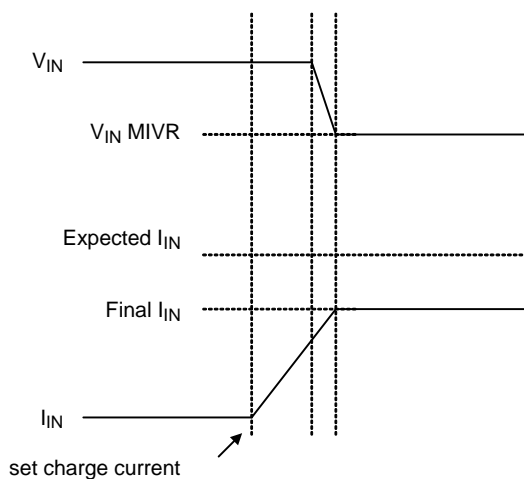

Figure 1

USB Power Source Detection (DPDM Detection)

An USB charger detection mechanism is integrated in RT9451 to detect between dedicated charger or not. The detection is triggered by VIN power on or DPDM_EN bit in the register address of 0x00h. The DPDM_EN bit is automatically reset to "0" after it is triggered. The DPDM detection status and result are reported in DPDM_D DPDM_R bits in the register address of 0x07h. The result is set to 975mA for dedicated charger (DP and DM pins short together) or 500mA for others. The detection mechanism can be disable by pulling VIO pin high.

Active Input Current Regulation (AICR)

The AICR setting is determined by both AICR [1:0] in register 0x02h, DPDM_R bit in register 0x07h and LMTSEL bit in register 0x01h. If LMTSEL bit is set to "0", the valid current limit is the maximum value of AICR [1:0] and DPDM_R result. If LMTSEL bit is set to "1", the AICR [1:0] dominates and DPDM_R result is ignored. For the latter, the input current limit of "00", "01" and "10" in AICR [1:0] corresponds to 100mA, 500mA and 975mA respectively. If the application does not need input current limit, write "11" into the AICR [1:0].

Charge Profile

The RT9451 provides a precision Li-ion or Li-polymer charging solution for single-cell applications. Input current limit, charge current, termination current, charge voltage and input voltage MIVR are all programmable via the I²C interface. In charge mode, the RT9451 has five control loops to regulate input current, charge current, charge voltage, input voltage MIVR and device junction temperature. During the charging process, all five loops are enabled and the dominant one will take over the control.

For normal charging process, the Li-ion or Li-polymer battery is charged in three charging modes depending on the battery voltage. At the beginning of the charging process, the RT9451 is in pre-charge mode. When the battery voltage rises above pre-charge threshold voltage (V_{PREC}), the RT9451 enters fast-charge mode. Once the battery voltage is close to the regulation voltage (V_{OREG}), the RT9451 enters constant voltage mode.

Pre-Charge Mode

For life-cycle consideration, the battery can not be charged with large current under low battery condition. When the BATS pin voltage is below pre-charge threshold voltage (V_{PREC}), the charger is in pre-charge mode with a weak charge current which equals to the pre-charge current (I_{PREC}). In pre-charge mode, the charger basically works as an LDO. The pre-charge current also acts as the current limit when the BATS pin is shorted.

Fast-Charge Mode and Settings

As the BATS pin rises above V_{PREC} , the charger enters fast-charge mode and the power MOSFETs starts switching. Unlike the linear charger, the switching charger is a current amplifier. The current drawn by the RT9451 is different from the current into the battery. The user can set the input current limit (I_{IN_LIMIT}) and output charge current (I_{CHRG}) respectively. The real charging current is determined by both I_{IN_LIMIT} [1:0] and V_{ICHRG} [3:0].

Cycle-by-Cycle Current Limit

The charger of the RT9451 has an embedded cycle-by-cycle current limit for inductor. Once the inductor current touches the threshold (5.5A min.), the charger stops charging immediately to prevent over current from damaging the device. Notice that, the mechanism can not be disabled by any way.

Low Current Charging (LOW_CHG)

The RT9451 has two charge current settings for the charge current in fast-charge mode. One is LOW_CHG bit, the other is V_{ICHRG} [3:0] bits. If LOW_CHG is set to "1", the charge current is limited to 150mA ($R_{SENSE} = 20m\Omega$). If LOW_CHG is set to "0", the charge current is determined by V_{ICHRG} [3:0] bits.

Charge Current (I_{CHRG})

The charge current into the battery is determined by the sense resistor (R_{SENSE}) and V_{ICHRG} [3:0] bits in the register of address 0x01. The voltage between the I_{SENL} and I_{SENR} pins is regulated to the voltage controlled by V_{ICHRG} [3:0]. The charge current equals to the voltage between the I_{SENL} and I_{SENR} pins (V_{ICHRG}) divided by R_{SENSE} :

$$I_{CHRG} = \frac{V_{ICHRG}}{R_{SENSE}}$$

For example, for a 20mΩ sense resistor, the charge current can be set from 1000mA (V_{ICHRG} [3:0] = "0000") to 4000mA (V_{ICHRG} [3:0] = "1111").

When input current limit and charge current are both set, the charge current in fast charge phase is calculated as below :

$$I_{CHRG} = \text{MIN} \left[\frac{V_{ICHRG}}{R_{SENSE}}, \left(\frac{I_{IN_LIMIT}}{D} \times \eta \right) \right]$$

where D is the duty cycle and η is the efficiency.

Constant Voltage Mode and Settings

The RT9451 enters constant voltage mode when the BATS voltage is close to the output-charge voltage (V_{OREG}). Once entering this mode, the charge current begins decreasing. For default settings (charge current termination is disabled, $TERM_EN = 0$), the RT9451 does not turn off and always regulates the battery voltage at V_{OREG} . However, once the charge current termination is enabled, the charger terminates if the charge current is below termination current (V_{ITERM} [2:0] / R_{SENSE}) in constant-voltage mode. The charge current termination function is controlled by $TERM_EN$ bit in the register of address 0x01 via the I²C interface. After termination, a new charge cycle restarts when one of the following conditions is detected :

- ▶ The BATS pin voltage falls below the $V_{OREG} - V_{RECH}$ threshold and CH_EN [1:0] = 11.
- ▶ V_{IN} Power On Reset (POR).
- ▶ CH_EN [1:0] is set from "0X" to "1X".

Output Charge Voltage (V_{OREG})

The output-charge voltage is set by the V_{OREG} [5:0] in the register 0x02h. Its range is from 3.5V to 4.45V. The default is 4V (011001).

Termination Current (I_{EOC})

If the charger current termination is enabled ($TERM_EN = "1"$), the end-of-charge current is determined by both the termination current sense voltage (V_{ITERM} [2:0]) and sense resistor (R_{SENSE}). V_{ITERM} range is from 1mV to 8mV with the step of 1mV. The end-of-charge current is calculated as below :

$$I_{EOC} = \frac{V_{ITERM}}{R_{SENSE}}$$

Recharge Behavior

There are two recharge behavior depending on CH_EN [1:0] setting. If CH_EN [1:0] = "11", the RT9451 will recharge automatically once BATS falls below $V_{OREG} - V_{RECH}$ threshold. If CH_EN [1:0] = "10", the RT9451 will not recharge automatically but set CHRECH flag and pull low INT pin to notify the host the battery need to be recharged.

Safety Timer in Charge Mode

To implement safety mechanism in charge mode, the RT9451 has a 32-minute timer. At the beginning of a charging operation, the RT9451 starts 32-minute timer that can be reset by any write or read action performed by the host through the I²C interface. Once 32-minute timer is expired, the RT9451 enters to high impedance mode. The I²C registers are all reset to default value and CH32M bit is set to "1" to prevent the charger against uncontrolled charging when the dead lock of the host occurs.

During normal charging process, the host needs to reset 32-minute timer periodically.

Input Voltage Protection in Charge Mode

During charge mode, there are three protection mechanisms against poor input power source and over-voltage condition : bad adapter detection, sleep mode and input over-voltage protection.

Bad Adapter Detection (CHBADI)

A mechanism is used to justify the power source capability when power on at the VIN pin. When VIN rises above $V_{IN(MIN)}$, a sink current of 30mA (typ.) is connected to VIN pin to detection adaptor status. After the detection period (30ms typ.), the sink current is removed. At the same time, if VIN is still above $V_{IN(MIN)}$, the detection passes and enters charge mode. If VIN is below $V_{IN(MIN)}$, the bad adapter condition occurs. The RT9451 stops working, sets CHBADI and repeats detection flow every 2 second (typ.).

Sleep Mode (VIN - VBATS < VSLP, CHRVP1)

The RT9451 enters sleep mode if the voltage drop between the VIN and BATS pins falls below V_{SLP} . In sleep mode,

the reverse blocking switch and PWM are all turned off. This function prevents battery drain during poor or no input power source.

Input Over-Voltage Protection (VINOVP1)

When VIN voltage raises above the input over-voltage threshold (V_{OVP_IN}), the RT9451 stops charging and then sets fault status bits and sends out fault pulse via the STAT pin. The condition is released when VIN falls below V_{OVP_IN} . The RT9451 then resumes charging operation.

Boost Mode Operation (OTG)

Trigger and Operation

The RT9451 features USB OTG support. There are two trigger method : One is to set CH_EN [1:0] = "01" (for I²C control), the other is to set OTG_EN, OTG_PL and OTG pin (for GPIO control). Notice that when using OTG pin to trigger boost mode, it needs an edge trigger and then keep it to the level defined by OTG_PL. When OTG function is enabled, the synchronous Boost control loop takes over the power MOSFETs and reverses the power flow from the battery to the VIN pin. In normal boost mode, the MID pin is regulated to the voltage level determined by VOREG [5:0] whose range is from 4.75 and provides up to 1.6A current to support other USB OTG devices connected to the USB connector.

Safety Timer in Boost Mode (BST32SI)

Initially, the RT9451 starts a 32-second timer that can be reset by any write or read action performed by the host through the I²C interface. Once 32-second timer is expired, the RT9451 enters to high impedance mode, the I²C registers are all reset to default value and BST32S bit is set to "1" to prevent the charger against uncontrolled discharging when the dead lock of the host occurs.

During normal discharging process, the host needs to reset 32-second timer periodically.

Output Over-Voltage Protection (VIN pin, BSTVINOVI)

In boost mode, the output over-voltage protection is triggered when the VIN voltage is above the output OVP

threshold (6V typ.). When OVP occurs, the RT9451 stop switching then enters high impedance mode.

Output Overload Protection (BSTOL)

The RT9451 provides an overload protection to prevent the device and battery from damage when VIN is in overload. Once the inductor current reaches cycle-by-cycle current limit, the reverse blocking switch operates in linear region to limit the output current while the MID voltage remains in voltage regulation. If the overload condition lasts for more than 30ms, the RT9451 determines the overload fault condition and resets registers to the default settings.

Status Output (STAT pin)

The STAT pin is used to indicate operating conditions of the RT9451 and is enabled by writing “00” to the EN_STAT [1:0] in the register of address 0x00. When charging is in progress, the STAT pin is pulled low. In other conditions, the STAT pin acts as a high impedance output. The STAT pin can also be always pulled low or high impedance by writing “01” and “10” respectively.

Battery Protection

Battery Over-Voltage Protection in Charge Mode (CHBATOVI)

The RT9451 monitors BATS voltage for output over-voltage protection. In charge mode, if the BATS voltage rises above $V_{OVP_BAT} \times V_{OREG}$, for example, when the battery is suddenly removed, the RT9450A stops charging and then sets fault status bits and pull low INT pin. The condition is released when BATS falls below $(V_{OVP_BAT} - \Delta V_{OVP_BAT}) \times V_{OVP_BAT}$. The RT9451 then resumes charging process with default settings and the fault is cleared.

Battery Over/Under-Voltage Protection in Boost Mode (BSTBATOVI, BSTLOWVI)

In boost mode, if the BATS voltage rises above the BATS maximum input voltage (4.75V typ.) or below BATS minimum input voltage (2.5V typ. for operating, 3V typ. for start), battery over/under-voltage protection is triggered. The RT9451 stops switching, and then enters high impedance mode.

Thermal Considerations

For continuous operation, do not exceed absolute maximum junction temperature. The maximum power dissipation depends on the thermal resistance of the IC package, PCB layout, rate of surrounding airflow, and difference between junction and ambient temperature. The maximum power dissipation can be calculated by the following formula :

$$P_{D(MAX)} = (T_{J(MAX)} - T_A) / \theta_{JA}$$

where $T_{J(MAX)}$ is the maximum junction temperature, T_A is the ambient temperature, and θ_{JA} is the junction to ambient thermal resistance.

For recommended operating condition specifications, the maximum junction temperature is 125°C. The junction to ambient thermal resistance, θ_{JA} , is layout dependent. For WQFN-32L 4x4 package, the thermal resistance, θ_{JA} , is 27.8°C/W on a standard JEDEC 51-7 four-layer thermal test board. The maximum power dissipation at $T_A = 25^\circ\text{C}$ can be calculated by the following formula :

$$P_{D(MAX)} = (125^\circ\text{C} - 25^\circ\text{C}) / (27.8^\circ\text{C/W}) = 3.59\text{W for WQFN-32L 4x4 package}$$

The maximum power dissipation depends on the operating ambient temperature for fixed $T_{J(MAX)}$ and thermal resistance, θ_{JA} . The derating curve in Figure 2 allows the designer to see the effect of rising ambient temperature on the maximum power dissipation.

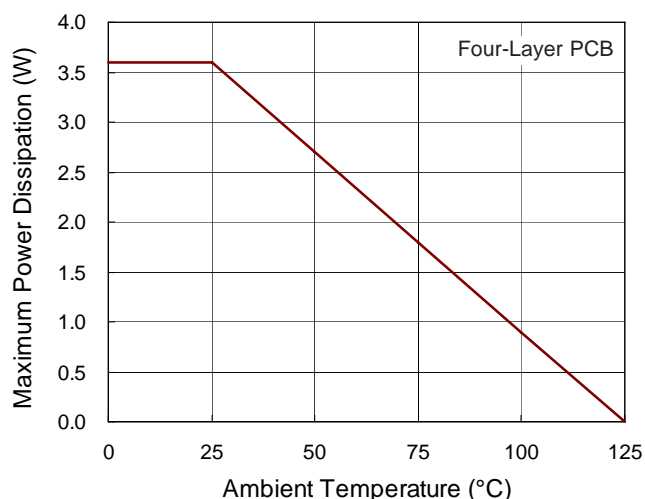

Figure 2. Derating Curve of Maximum Power Dissipation

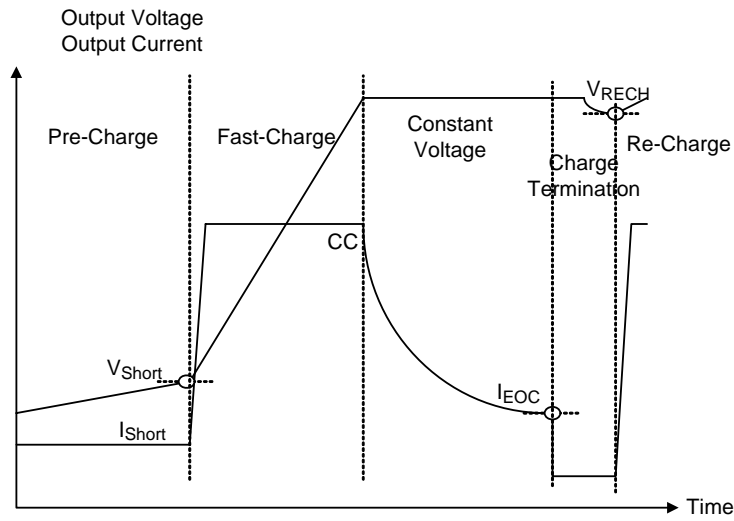

Figure 3. Charging I-V Curve

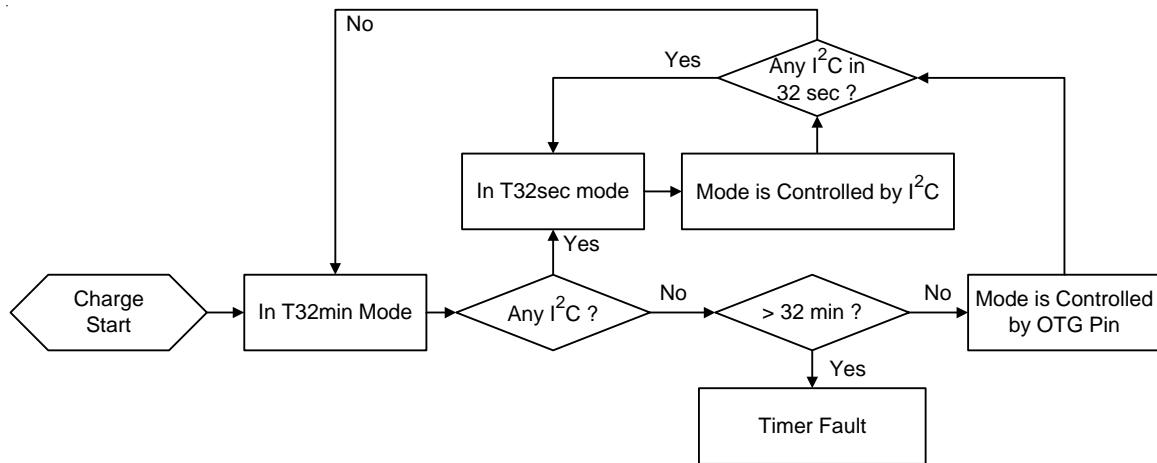

Figure 4. Safety Timer

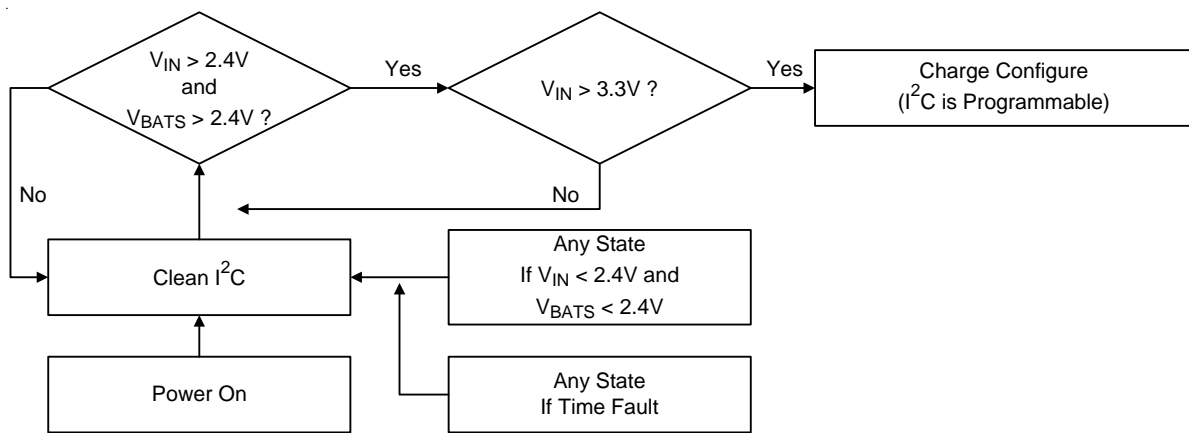

Figure 5. POR Reset

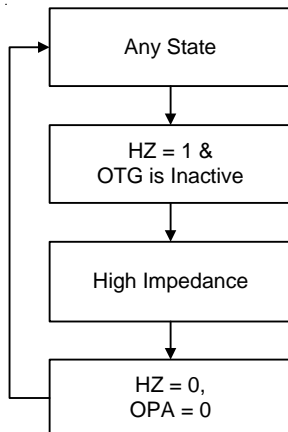

Figure 6. High Impedance Mode

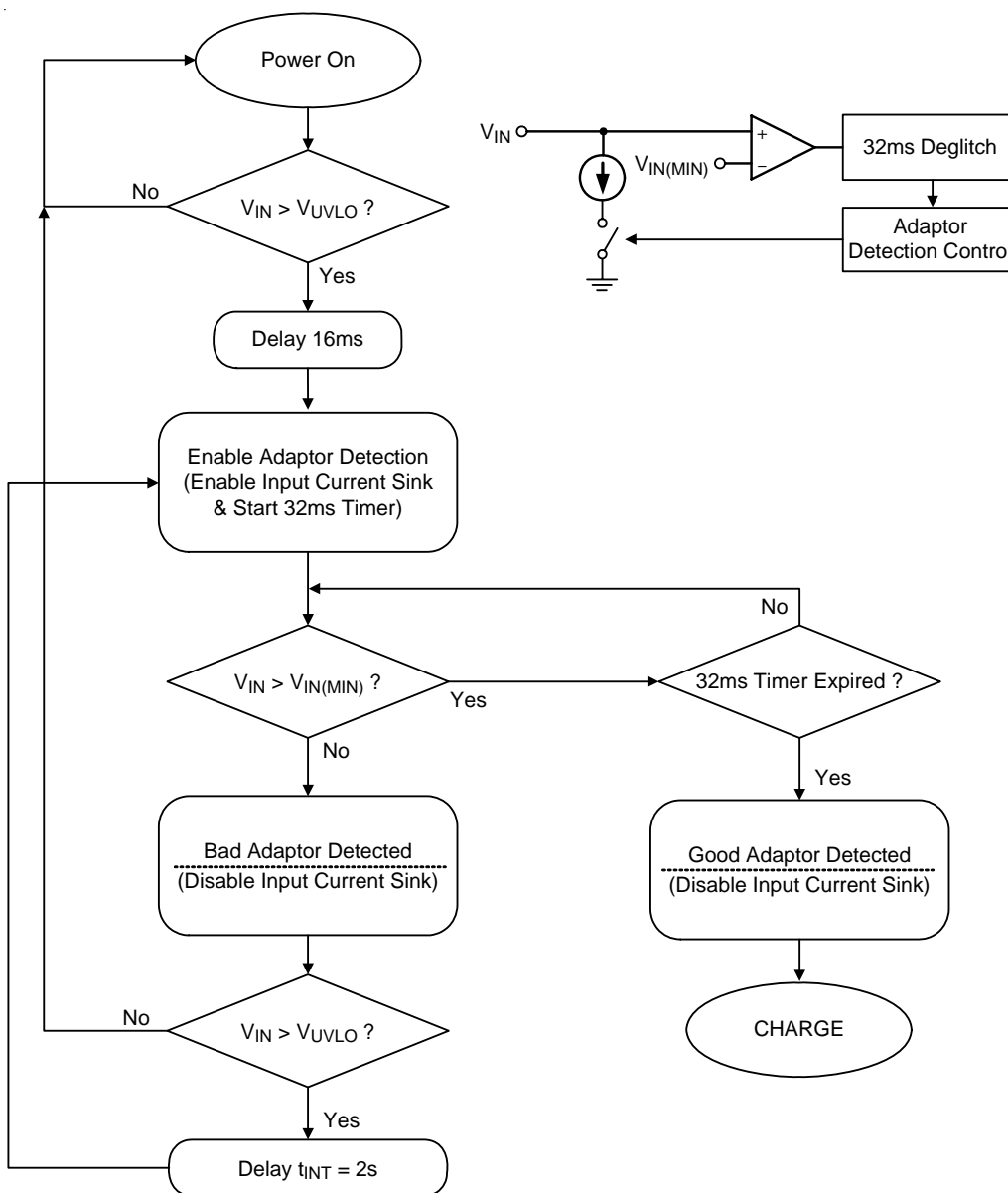

Figure 7. Input Power Source Detection

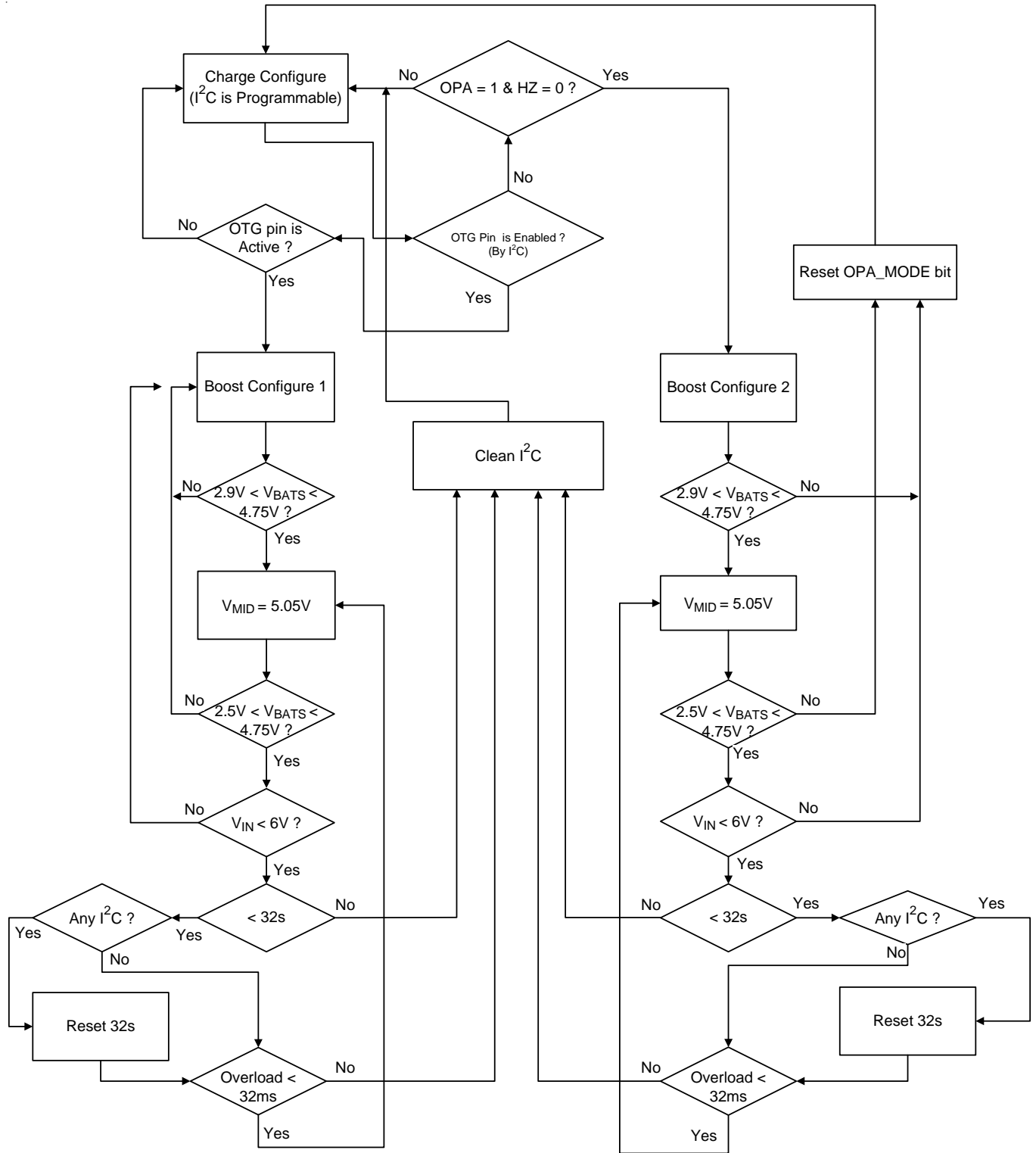

Figure 8. OTG Mode

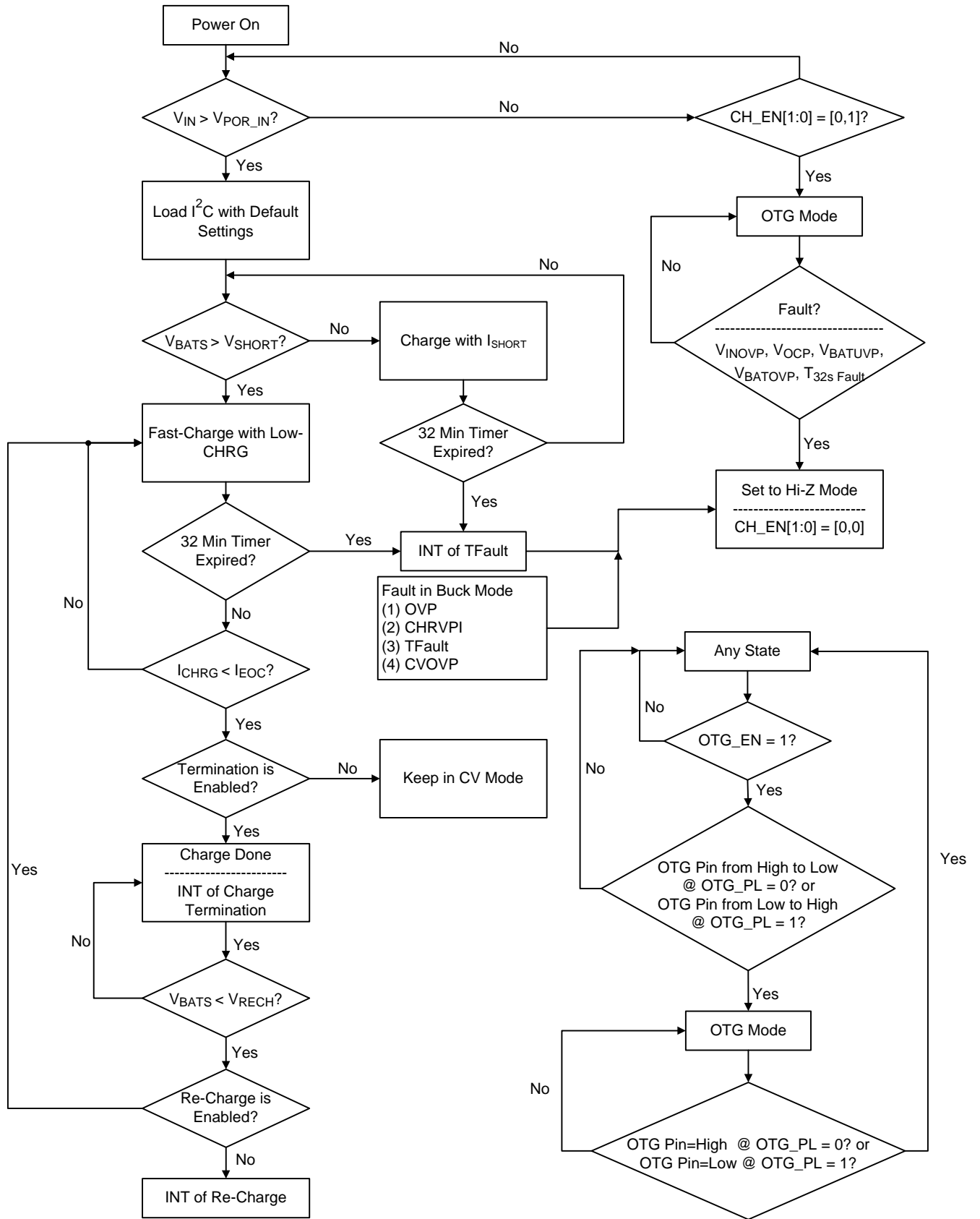

Figure 9. Operation Flow Chart

Layout Considerations

Place the input and output capacitors as close to the input and output pins as possible.

- ▶ Keep the main power traces as wide and short as possible.
- ▶ The output inductor and bootstrap capacitor should be placed close to the chip and LX pins.
- ▶ To optimize current sense accuracy, connect the traces to R_{SENSE} with Kelvin sense connection.

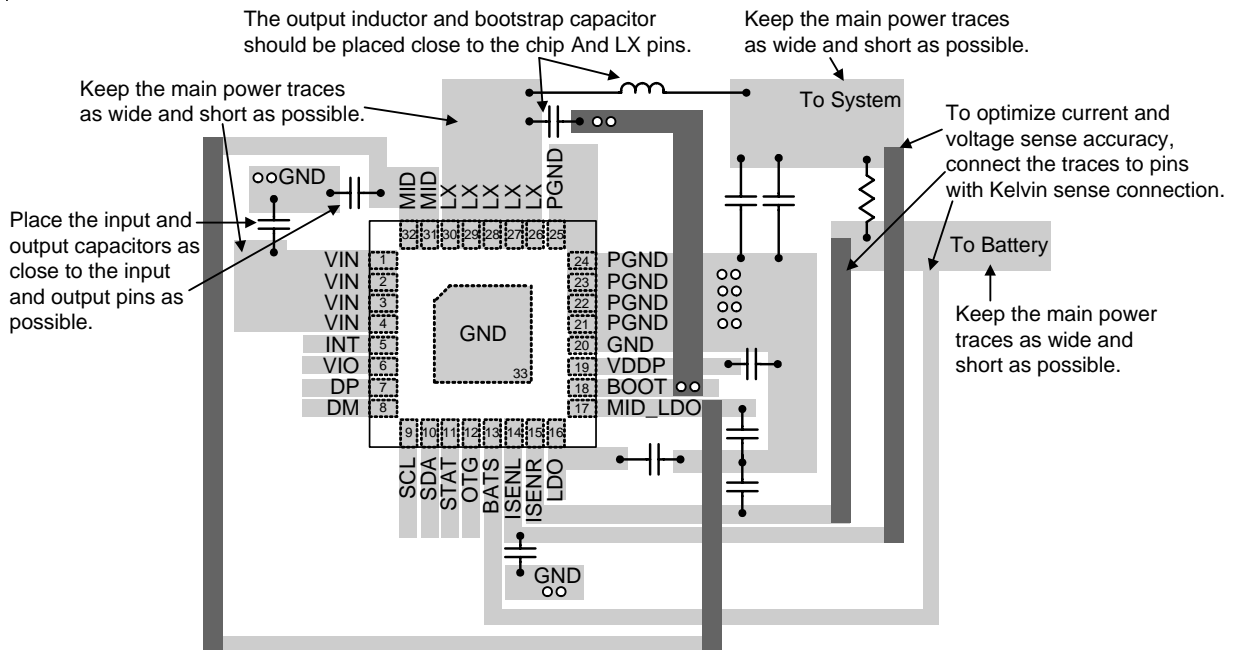
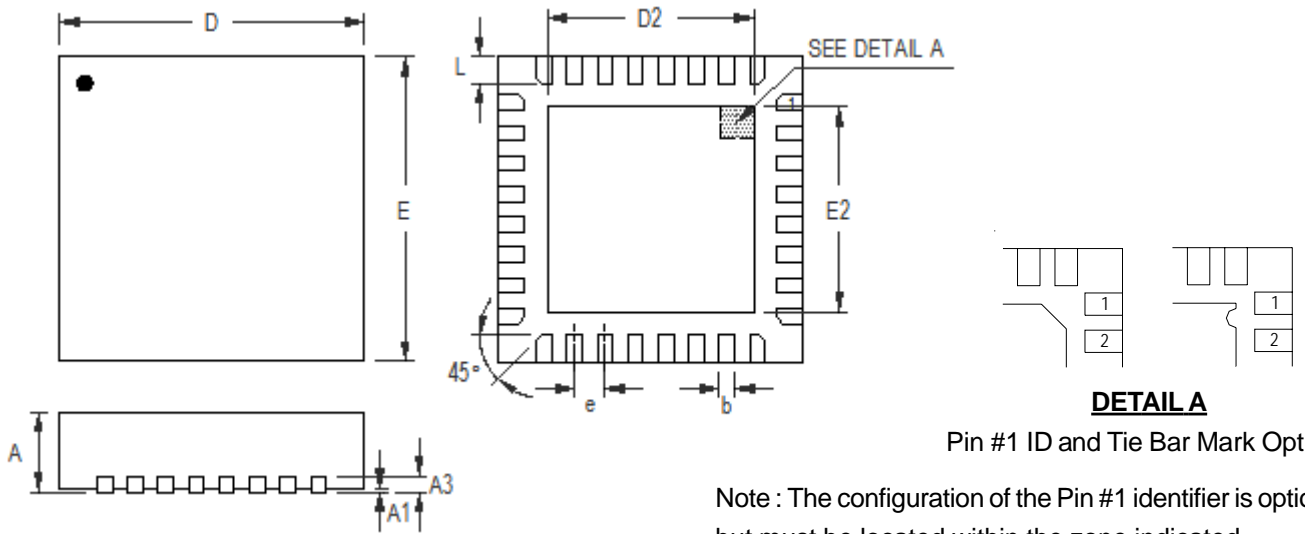

Figure 10. PCB Layout Guide

Outline Dimension



DETAIL A
Pin #1 ID and Tie Bar Mark Options

Note : The configuration of the Pin #1 identifier is optional, but must be located within the zone indicated.

Symbol	Dimensions In Millimeters		Dimensions In Inches	
	Min	Max	Min	Max
A	0.700	0.800	0.028	0.031
A1	0.000	0.050	0.000	0.002
A3	0.175	0.250	0.007	0.010
b	0.150	0.250	0.006	0.010
D	3.900	4.100	0.154	0.161
D2	2.650	2.750	0.104	0.108
E	3.900	4.100	0.154	0.161
E2	2.650	2.750	0.104	0.108
e	0.400		0.016	
L	0.300	0.400	0.012	0.016

W-Type 32L QFN 4x4 Package

Richtek Technology Corporation

5F, No. 20, Taiyuen Street, Chupei City
Hsinchu, Taiwan, R.O.C.
Tel: (8863)5526789

Richtek products are sold by description only. Richtek reserves the right to change the circuitry and/or specifications without notice at any time. Customers should obtain the latest relevant information and data sheets before placing orders and should verify that such information is current and complete. Richtek cannot assume responsibility for use of any circuitry other than circuitry entirely embodied in a Richtek product. Information furnished by Richtek is believed to be accurate and reliable. However, no responsibility is assumed by Richtek or its subsidiaries for its use; nor for any infringements of patents or other rights of third parties which may result from its use. No license is granted by implication or otherwise under any patent or patent rights of Richtek or its subsidiaries.