

5A Single Cell Li-Ion Switching Battery Charger with Direct Charge, Power Path Management and USB OTG Boost Mode

General Description

The RT9468 is a switch-mode single cell Li-Ion/Li-Polymer battery charger for portable applications. It integrates a synchronous PWM controller, power MOSFETs, input current sensing and regulation, high-accuracy voltage regulation, and charge termination. The charge current is regulated through integrated sensing resistors. The RT9468 also features USB On-The-Go (OTG) support. The RT9468 integrates an easy-to-use direct charge function, simply driving an external MOSFET to enable a direct charge path, as well as over-voltage protection, over-current protection, and watchdog functions.

The RT9468 optimizes for charging task by using a control algorithm to vary the charge rate for different modes, including pre-charge mode, fast charge mode (constant voltage and constant current). The key charge parameters are programmable through an I²C interface. The RT9468 will resume the charge cycle whenever the battery voltage falls below an internal recharge threshold, and can automatically enter sleep mode if the input power supply is removed.

Other features include under-voltage protection, over-voltage protection, thermal regulation and reverse leakage protection.

The RT9468 is available in a WQFN-32L 4x4 package.

Applications

- Cellular Telephones
- Personal Information Appliances
- Tablet PC, Power Bank
- Portable Instruments

Features

- **Direct Charge with Over-Voltage Protection, Over-Current Protection and Watchdog**
- **High Efficiency 5A, 1.5MHz Switching Charger with Output Inductor DFE252012F, TOKO**
 - ▶ Charging Efficiency 90.25% at ICHG = 2A
 - ▶ Charging Efficiency 88.86% at ICHG = 3A
 - ▶ Charging Efficiency 84.2% at ICHG = 5A
- **Synchronous 1.5MHz/0.75MHz Fixed-Frequency PWM Controller with Up to 95% Duty Cycle**
- **Power Path Management by BATFET Control**
- **Support High Voltage Input (9V/12V)**
- **Support High Voltage Input Adapter (Pump Express 1.0/2.0/3.0)**
- **Support IR Compensation Function from Charger Output to Cell Terminal**
- **Optimize Input Sourcing Capability to Prevent Overload**
 - ▶ AICR Current Limit Setting via I²C
 - ▶ ILIM Pin for Current Limit Setting
 - ▶ Average Input Current Limit Measurement
- **Shipping Mode for Battery Leakage Reduction**
 - ▶ Wake Up System, Exit Shipping Mode, and Reset System by QON Pin
- **Automatic Charging**
- **Average Input Current Regulation (AICR) : 0.1A to 3.25A in 50mA Steps**
- **Charge Current Regulation Accuracy : ±7%**
- **Charge Voltage Regulation Accuracy : ±1% (0 to 85°C)**
- **Protection for Overall System Considerations**
 - ▶ Thermal Regulation for Current Reduction and Over-Temperature Protection
 - ▶ Input Over-Voltage Protection
 - ▶ Input Bad Adapter Protection
 - ▶ Battery Over-Voltage Protection
- **Support ADC Conversion for**
 - ▶ VBUS, VBAT, VSYS, REGN, TS_BAT, IBUS, IBAT, TEMP_JC, TS_BUS,VBATS, IBATS
- **INT Output for Communication with Host Through I²C (Watch Dog / Polling Function)**

Ordering Information

RT9468 □ □

- Package Type
QW : WQFN-32L 4x4 (W-Type)
- Lead Plating System
G : Green (Halogen Free and Pb Free)

Note :

Richtek products are :

- ▶ RoHS compliant and compatible with the current requirements of IPC/JEDEC J-STD-020.
- ▶ Suitable for use in SnPb or Pb-free soldering processes.

Marking Information

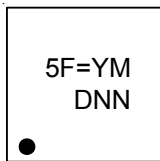

5F= : Product Code
YMDNN : Date Code

Pin Configuration

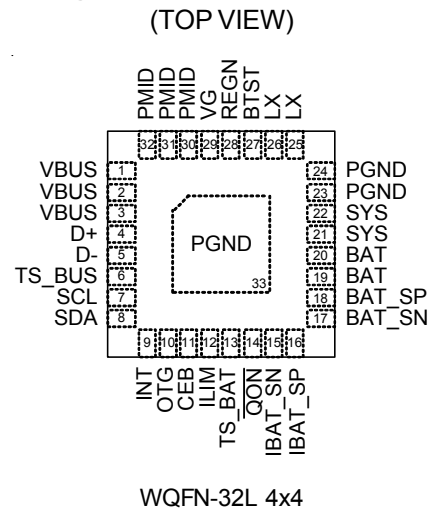

Typical Application Circuit

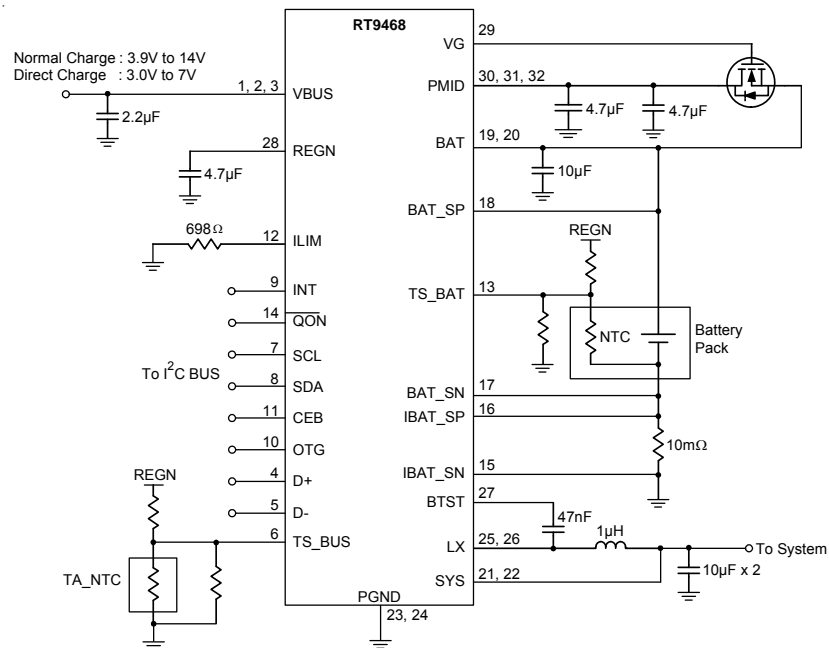

Below are recommended components information

Pin	Description	Part Number	Package	Manufacturer
VBUS	2.2µF/25V/X5R	GRM155R61E225KE11	0402	muRata
PMID	4.7µF/25V/X5R	GRM188R61E475KE11	0603	muRata
BTST	47nF/16V/X5R	GRM033R61C473KE84	0201	muRata
SYS	10µF/6.3V/X5R	GRM185R60J106ME15	0603	muRata
REGN	4.7µF/6.3V/X5R	GRM155R60J475ME47	0402	muRata

Pin	Description	Part Number	Package	Manufacturer
BAT	10 μ F/6.3V/X5R	GRM185R60J106ME15	0603	muRata
LX	1 μ H/20%	DFE252012F-1R0	2.5 x 2.0mm	TOKO
VG	NMOS	DMT2004UFDF_R0	2.0 x 2.0mm	DIODES
ILIM	698 Ω /1%	RR0306S-6980-FNH	0201	CYNTEC

Functional Pin Description

Pin No.	Pin Name	Pin Description
1, 2, 3	VBUS	Power input.
4	D+	USB D+ Port Connected to USB Receptacle.
5	D-	USB D- Port Connected to USB Receptacle.
6	TS_BUS	BUS temperature-sense input, connected to a resistor divider for temperature programming. If there is no need for the battery temperature-sense function, a 50k Ω resistor is connected to REGN and another 50k Ω resistor to ground.
7	SCL	I ² C interface serial clock input. Open-drain. An external pull-up resistor is required.
8	SDA	I ² C interface serial data input/output. Open-drain. An external pull-up resistor is required.
9	INT	Interrupt output, active-low open-drain. Indicator of the charger/boost event for system processor.
10	OTG	OTG boost mode enable control, active-high. Act with OTG_PIN_EN (0x01[1]).
11	CEB	Charger enable input, active-low.
12	ILIM	Input current limit setting pin. A resistor is connected from ILIM pin to ground to set the maximum input current limit. The actual input current limit is the lower value set through the ILIM pin and IAICR register bits.
13	TS_BAT	Battery temperature-sense input, connected to a resistor divider for temperature programming. If there is no need for the battery temperature-sense function, a 50k Ω resistor is connected to REGN and another 50k Ω resistor to ground.
14	\overline{QON}	Internal BATFET enable control input. In shipping mode, \overline{QON} is pulled Low for the duration of t _{SHIPMODE} (typical 0.9s) to exit shipping mode.
15	IBAT_SN	Negative battery current sense.
16	IBAT_SP	Positive battery current sense.
17	BAT_SN	Negative battery voltage sense.
18	BAT_SP	Positive battery voltage sense.
19, 20	BAT	Battery connection node. Charging current output node. Internal BATFET is connected between SYS and BAT.
21, 22	SYS	System connection node. The internal BATFET is connected between SYS and BAT. Connect a 20 μ F ceramic capacitor between SYS and ground.
23, 24	PGND	Power ground connection.
25, 26	LX	Switch node for output inductor connection.
27	BTST	Bootstrap capacitor connection for high-side gate driver. Connect a capacitor from BTST to LX to power the internal gate driver.

Pin No.	Pin Name	Pin Description
28	REGN	Regulated output voltage to supply for the PWM low-side gate driver and the bootstrap capacitor. Connect a 4.7 μ F ceramic capacitor from REGN to GND. 1.If VBUS is plugged in, REGN will be powered by VBUS and regulated to 4.9V. 2.If VBUS is unplugged, the charger will operate in sleep mode and the REGN voltage will be 0V. * For #2. : Since the REGN voltage is also used to power the TS resistor, when the charger is in sleep mode, the REGN will be woken up (be reactivated) if VBAT is greater than forward voltage (V _F) of the internal high-side (HS) MOS diode by V _{SLEEP_EXIT} with all function of the internal ADC being activated and I ² C R/W. The REGN wake-up time is 500ms.
29	VG	Gate driver output for external N-MOSFET.
30, 31, 32	PMID	Connection point between the reverse blocking MOSFET and the high-side switching MOSFET.
33 (Exposed Pad)	PGND	Power ground. The exposed pad must be connected to GND and well soldered to a large PCB copper area for maximum power dissipation.

Functional Block Diagram

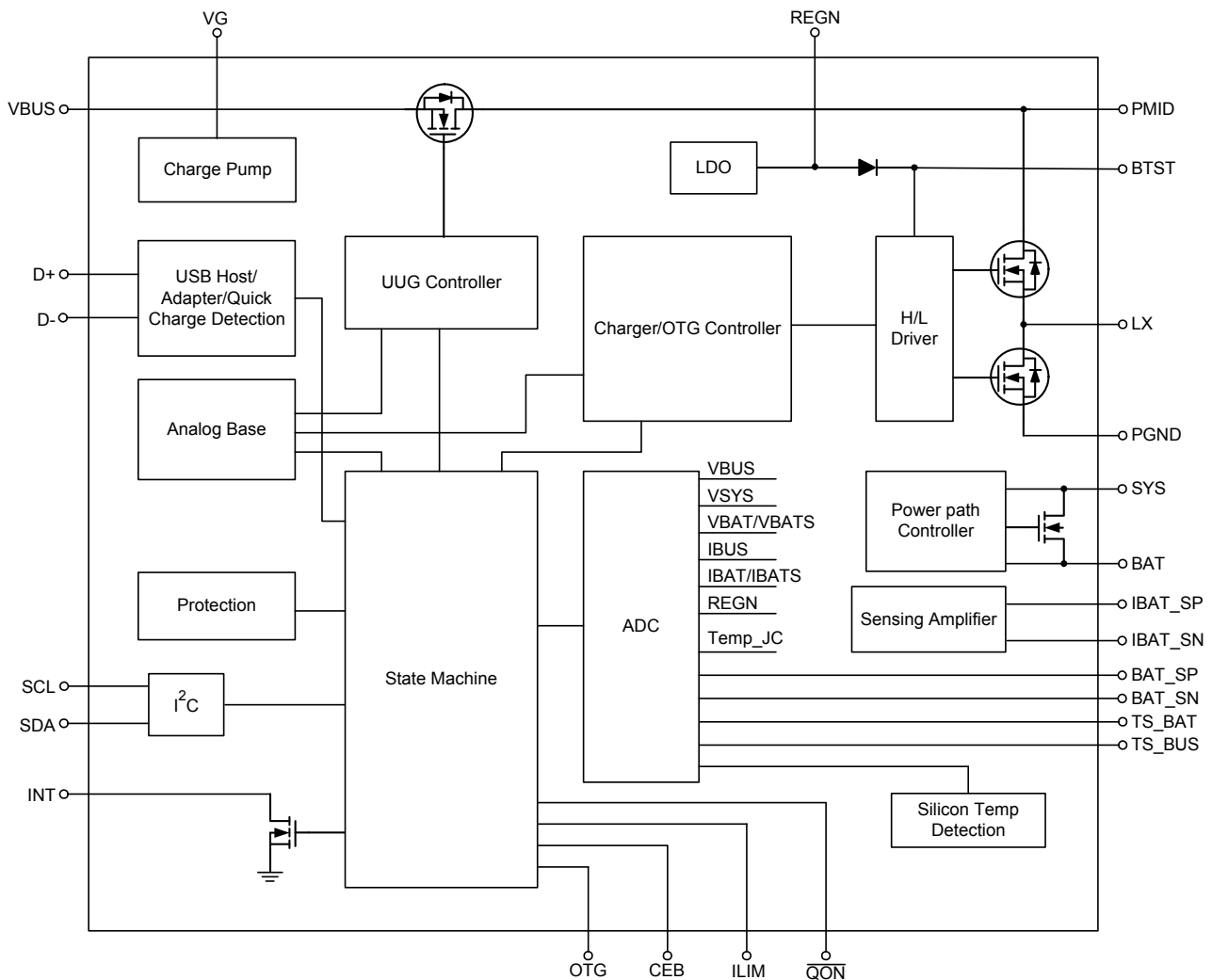

Operation

The RT9468 is an integrated single cell Li-ion battery switching charger with power path controller.

Base Circuits

Base circuits provide the internal power, VREGN and reference voltage and bias current.

Protection Circuits

The protection circuits include the VINOVP, VINUVLO, BATOVP and OTP circuits. The protection circuits turn off the charging when the input power or die temperature is in abnormal level.

Buck Regulator for Charging and Boost Regulator as OTG

The multi-loop controller controls the operation of charging process and current supply to the system. It also controls the circuits as a Boost converter for OTG applications.

Battery Detection

The RT9468 is capable of doing the battery absence detection. The detection protects the charger when battery is removed accidentally.

Adapter Detection

If the poor input power source is connected to the RT9468, the operation will be shut down by the adapter detection.

Power Path Management and Control

Once the battery voltage increases to a defined system minimum regulation voltage, the internal path between SYS and BAT will be fully turned on. That is, a better charging efficiency can be achieved. When end of charge occurs, the charging will stop and the internal path will be turned off.

USB Charger Detection

The RT9468 can detect and distinguish Standard Downstream Port, Charging Downstream Port and Dedicated Charging Port via DP and DM pins.

TS Detection

The RT9468 detects the temperature of the battery pack via REGN and TS pins. The REGN pin provides a constant voltage source to drive the voltage divider composed of a pulled-high resistor and a NTC resistor. The RT9468 reports the sensing results via IRQ and status bits for COLD, COOL, WARM and HOT.

I²C Controller

The key parameters of charging and OTG are programmable through I²C commands.

Absolute Maximum Ratings (Note 1)

• Supply Input Voltage, V _{BUS} -----	-0.3V to 22V
• Supply Input Voltage, V _{BUS} (Peak <100ns duration) -----	-2V
• PMID, BTST -----	-0.3V to 22V
• LX -----	-0.3V to 16V
• LX (Peak < 100ns duration) -----	-2V
• PMID – V _{BUS} , BTST – LX -----	-0.3V to 6V
• Other Pins-----	-0.3V to 6V
• Power Dissipation, P _D @ T _A = 25°C	
WQFN-32L 4x4 -----	3.59W
• Package Thermal Resistance (Note 2)	
WQFN-32L 4x4, θ _{JA} -----	27.8°C/W
WQFN-32L 4x4, θ _{JC} -----	7°C/W
• Lead Temperature (Soldering, 10 sec.)-----	260°C
• Junction Temperature-----	150°C
• Storage Temperature Range -----	-65°C to 150°C
• ESD Susceptibility (Note 3)	
HBM (Human Body Model)-----	2kV

Recommended Operating Conditions (Note 4)

• Supply Input Voltage-----	4V to 14V
• Maximum Input Current (V _{BUS}), I _{AICR} -----	3.25A
• Maximum V _{BUS} to PMID Current-----	6A
• Maximum SYS Output Current (SW), I _{SYS} -----	5A
• Maximum Battery Voltage, V _{BAT} -----	4.71V
• Maximum I _{BAT} Fast Charging Current -----	5A
• Maximum I _{BAT} Discharging Current -----	6A
• Maximum I _{BAT} Discharging Current peak, 1sec duration -----	9A
• Junction Temperature Range-----	-40°C to 125°C
• Ambient Temperature Range-----	-40°C to 85°C

Electrical Characteristics

(V_{BUS} = 5V, V_{BAT} = 4.2V, L = 1μH, C_{IN} = 2.2μF, C_{BATS} = 10μF, T_A = 25°C, unless otherwise specified)

Parameter	Symbol	Test Conditions	Min	Typ	Max	Unit
Quiescent Current						
V _{BUS} Supply Current	I _{VBUS_SW}	V _{LX} is switching, V _{BUS} = 5V, V _{SYS} = 3.8V	--	8	--	mA
	I _{VBUS_NON_SW}	V _{LX} is non-switching, V _{BUS} = 5V, V _{SYS} = 4.4V	--	--	5	mA
	I _{VBUS_HZ}	V _{LX} is in high-impedance mode, V _{BUS} = 5V, V _{SYS} = 3.8V	--	--	150	μA
Battery Leakage Current	I _{BAT_LEAK}	Power path is off, V _{BAT} = 4.2V	--	--	25	μA
Boost-Mode Battery Discharge Current	I _{BAT_BOOST_SW}	V _{BAT} = 4.2V, boost mode, I _{VBUS} = 0A, V _{LX} is switching	--	5	--	mA

Parameter	Symbol	Test Conditions	Min	Typ	Max	Unit
V_{BUS} / V_{BAT} Power-Up						
Sleep-Mode Entry Threshold, V _{BUS} -V _{BAT}	V _{SLEEP_ENTER}	2.5V < V _{BAT} < V _{OREG} , V _{BUS} falling	0	40	100	mV
Sleep-Mode Exit Threshold, V _{BUS} -V _{BAT}	V _{SLEEP_EXIT}	2.5V < V _{BAT} < V _{OREG} , V _{BUS} rising	40	100	200	mV
Direct Charge Sleep-Mode Entry Threshold, V _{BUS} -V _{BAT}	V _{SLEEP_ENTER_DC}		--	--	40	mV
Direct Charge Sleep-Mode Exit Threshold, V _{BUS} -V _{BAT}	V _{SLEEP_EXIT_DC}		40	--	--	mV
Sleep-Mode Exit Deglitch Time	t _{D_SLEEP_EXIT}	Exit sleep-mode	--	120	--	ms
V _{BUS} Bad Adapter Threshold	V _{BAD_ADP}		--	3.8	--	V
V _{BUS} Bad Adapter Hysteresis	V _{BAD_ADP_HYS}		--	150	--	mV
V _{BUS} Bad Adapter Sink Current	I _{BAD_ADP_SINK}		--	50	--	mA
V _{BUS} Bad Adapter Detection Time	t _{BAD_ADP_DET}		--	30	--	ms
Input Current Limit Factor	K _{ILIM}	Input current regulation 508mA by ILIM pin with resistance = 698Ω	320	355	390	AΩ
Input Current Limit Regulation	I _{ILIM_MIN}	Minimum input current for regulation on ILIM pin	0.5	--	--	A
Input Power Regulation						
Minimum Input Voltage Regulation (MIVR) Threshold Range	V _{MIVR}	I ² C programmable in 0.1V steps	3.9	--	13.4	V
Default Minimum Input Voltage Regulation Threshold	V _{MIVR_DEF}	Default	--	4.4	--	V
Minimum Input Voltage Regulation Accuracy	V _{MIVR_ACC}	V _{MIVR} = 4.4V, 9V	-3	--	3	%
Average Input Current Regulation Accuracy	I _{AICR_ACC}	USB charge mode, I _{AICR} = 100mA	86	93	100	mA
		USB charge mode, I _{AICR} = 500mA	440	470	500	
		USB charge mode, I _{AICR} = 1000mA	880	940	1000	mA
		Adapter 1.5A charge mode, I _{AICR} = 1500mA	1300	1400	1500	mA
Direct Charge						
Direct Charge UC Level	I _{DIRCHG_UC}		--	650	--	mA
Direct Charge OV Level	V _{DIRCHG_OV}	(V _{DIRCHG_Rising} - V _{OREG})/V _{OREG}	104	108	112	%
Direct Charge OC Setting Range	I _{DIRCHG_OC}		4	--	6.5	A
Direct Charge V _{BUSOV} Setting Range	V _{DIRCHG_VBUSOV}		3.9	--	7	V

Parameter	Symbol	Test Conditions	Min	Typ	Max	Unit
Direct charge Watch Dog Timer Range	t _{DIRCHG_WDT}		0	--	8	s
Deviation between VG and Battery (V _{VG} – V _{BAT})	V _{VG} – V _{BAT}	V _{BAT} > 3.4V, (0x18,bit[1] = 0)	4.5	5	7	V
		V _{BAT} > 3.4V, (0x18,bit[1] = 1)	8	10	12	V
Protection						
V_{BUS}						
V _{BUS} Under-Voltage Protection Threshold	V _{UVLO}	V _{BUS} rising	3.05	3.3	3.55	V
V _{BUS} Under-Voltage Protection Hysteresis	V _{UVLO_HYS}	V _{BUS} falling from UVLO	--	150	--	mV
V _{BUS} Over-Voltage Protection Threshold	V _{BUS_OVP}	V _{BUS} rising	14	14.5	15	V
V _{BUS} Over-Voltage Protection Hysteresis	V _{BUS_OVP_HYS}	V _{BUS} falling	--	250	--	mV
V_{BAT}						
Battery Over-Voltage Protection Threshold	V _{BAT_OVP}	V _{BAT} rising, as percentage of V _{OREG} , as (V _{BAT_OVP} -V _{OREG})/V _{OREG}	106	108	110	%
Battery Over-Voltage Protection Hysteresis	V _{BAT_OVP_HYS}	V _{BAT} falling, as (V _{BAT_OVP_HYS})/V _{OREG}	--	4	--	%
Thermal Protection						
Over-Temperature Protection Threshold	T _{OTP}	Thermal shutdown threshold temperature	--	160	--	°C
Over-Temperature Protection Hysteresis	T _{OTP_HYS}	Thermal shutdown hysteresis temperature	--	30	--	°C
Thermal Regulation Threshold	T _{TR}	Charge current starts decreasing	--	120	--	°C
V_{sys}						
V _{sys} Over-Voltage Protection Threshold	V _{sys_OVP}	V _{sys} rising	--	5.25	--	V
V _{sys} Under-Voltage Protection Threshold	V _{sys_UVP}	V _{sys} falling	--	2.4	--	V
Battery Charging Stages						
End of Charge						
Regulated Battery Voltage Range	V _{OREG}	I ² C programmable in 10mV steps	3.9	--	4.71	V
Regulated Battery Voltage	V _{OREG_DEF}	Default	--	4.2	--	V
Regulated Battery Voltage Accuracy	V _{OREG_ACC}	Temperature = 0 to 85°C	-1	--	1	%
Re-Charge Mode Threshold	V _{RECH}	V _{BAT} falling, the difference below V _{OREG} , (0x0B[2:0] = 00)	50	100	150	mV
Re-Charge Deglitch Time	t _{D_RECH}		--	120	--	ms

Parameter	Symbol	Test Conditions	Min	Typ	Max	Unit	
End-of-Charge Current	I _{EOC}	I ² C programmable in 50mA steps	100	--	850	mA	
Default End-of-Charge Current	I _{EOC_DEF}	Default	--	250	--	mA	
End-of-Charge Current Accuracy	I _{EOC_ACC}		-20	--	20	%	
Default End-of-Charge Deglitch Time	t _{D_EOC}	Default	--	2	--	ms	
Fast Charge							
Charge Current Range	I _{CHG}	I ² C programmable in 0.1A steps	0.1	--	5	A	
Charge Current Accuracy	I _{CHG_ACC}	V _{BAT} = 3.8V	I _{CHG} < 500mA	-20	--	20	%
			500mA < I _{CHG} < 1000mA	-10	--	10	%
			I _{CHG} > 1000mA	-7	--	7	%
Pre-Charge							
Pre-Charge Mode Threshold	V _{PRECHG}	I ² C programmable in 0.1V steps	2	--	3.5	V	
Pre-Charge Mode Hysteresis	V _{PRECHG_HYS}	Pre-charge hysteresis, falling	--	0.2	--	V	
Pre-Charge Mode Threshold Accuracy	V _{PRECHG_ACC}		-5	--	5	%	
Pre-Charge Current Range	I _{PRECHG}	I ² C programmable in 50mA steps	100	--	850	mA	
Default Pre-Charge Current	I _{PRECHG_DEF}	Default	--	150	--	mA	
Pre-Charge Current Accuracy	I _{PREC_ACC}		-20	--	20	%	
Trickle Charge							
Trickle Charge Threshold	V _{TRICHG}	V _{BAT} falling	--	2	--	V	
Trickle Charge Threshold Hysteresis	V _{TRICHG_HYS}	V _{BAT} rising	--	200	--	mV	
Trickle Charge Threshold Accuracy	V _{TRICHG_ACC}		-5	--	5	%	
Trickle Current	I _{TRICHG}	V _{BAT} < 2V, charge with ICC = 100mA V _{BAT} < 1.6V, charge with AICR = 100mA	--	100	--	mA	
Trickle Current Accuracy	I _{TRICHG_ACC}		-20	--	20	%	
V_{sys}							
System Regulation Voltage	V _{sysREG}	Minimum system regulation voltage, I ² C programmable in 0.1V steps	3.3	--	4	V	
Default System Regulation Voltage	V _{sysREG_DEF}	Default minimum system regulation voltage	--	3.6	--	V	

Parameter	Symbol	Test Conditions	Min	Typ	Max	Unit
System Regulation Accuracy	V _{SYREG_ACC}		-5	--	5	%
Battery Charger						
UUG On-Resistance	R _{ON_UUG}	From VBUS to PMID	--	15	30	mΩ
High-Side On-Resistance	R _{ON_UUG_UG}	From VBUS to LX	--	42	79	mΩ
Low-Side On-Resistance	R _{ON_LG}	From LX to PGND	--	28	40	mΩ
Power-Path-Side On-Resistance	R _{ON_PPMOS}	From SYS to BAT	--	13	30	mΩ
Switching Frequency (1.5MHz)	f _{OSC1}	I ² C programmable to 1.5 MHz (0x01[7] = 0)	--	1.5	--	MHz
Switching Frequency (750kHz)	f _{OSC2}	I ² C programmable to 0.75MHz (0x01[7] = 1)	--	0.75	--	MHz
Frequency Accuracy	f _{OSC_ACC}		-10	--	10	%
Maximum Duty Cycle	D _{MAX}	At minimum input voltage	--	97	--	%
Minimum Duty Cycle	D _{MIN}		0	--	--	%
REGN Regulation	V _{REGN}	V _{BUS} = 5V / 9V / 12V	--	4.9	--	V
REGN Current Limit	I _{LIM_REGN}	V _{BUS} = 5V / 9V / 12V	50	--	--	mA
Sink Current for Battery Detection	I _{BAT_SINK}		--	300	--	μA
Internal QON Pull-Up Resistance	R _{QON}		--	200	--	kΩ
Internal QON Pull-Up	V _{QON}	Battery only	--	V _{BAT}	--	V
		V _{BUS} = 5V/9V	--	4.8	--	
QON Exit Shipping Mode Time	t _{SHIPMODE}	QON Low for BATFET on-time to exit shipping mode	--	0.9	--	sec
System Reset by QON Pin	t _{QON_RST}	QON low time to enable full system reset	--	10	--	sec
BATFET Reset Time	t _{BATFET_RST}	BATFET off-time during full system reset	--	0.41	--	sec
Shipping Mode Entry Deglitch Time	t _{D_SM_ENTER}	Enter shipping mode	--	9	--	sec
AICL	V _{AICL}	V _{BUS} rising, I ² C programmable	--	4.6	--	V
AICL Hysteresis	V _{AICL_HYS}		--	50	--	mV
OTG Boost Mode Operation						
OTG Boost-Mode Output Regulation Voltage Range	V _{OTGBST}	To VBUS	4.425	--	5.825	V
OTG Boost-Mode Output Regulation Voltage Accuracy	V _{OTGBST_ACC}		-3	--	3	%
OTG Boost-Mode Over-Load Protection Threshold	I _{OTG_OLP}	I ² C programmable	0.5	--	2.4	A

Parameter	Symbol	Test Conditions	Min	Typ	Max	Unit
OTG Boost-Mode Default Over-Load Protection Threshold	I _{OTG_OLP_DEF}	0x0A [2:0] = 000	--	0.5	--	A
OTG Low Battery Protection Threshold	V _{OTG_LBP}	I ² C programmable, hysteresis = 0.4 V	2.3	--	3.8	V
OTG Default Low Battery Protection Threshold	V _{OTG_LBP_DEF}	OTG_LBP = 2.8V (Addr0x0A[7:4] = 0101)	--	2.8	--	V
OTG Low Battery Protection Threshold Accuracy			-5	--	5	%
OTG PMID Over-Voltage Protection	V _{OTG_PMI_D_OVP}	V _{PMID} rising	--	6	--	V
OTG PMID Over-Voltage Protection Hysteresis	V _{OTG_PMI_D_OVP_HYS}		--	200	--	mV
Inductor Over-Current Protection Threshold	I _{OCP}	Inductor OCP level for both buck and boost modes	--	6	--	A
Current Pulse Control, PE1.0						
Current Pulse Control Stop Pulse	t _{PUMPX_STOP}		430	--	570	ms
Current Pulse Control Long On Pulse	t _{PUMPX_ON1}		240	--	360	ms
Current Pulse Control Short On Pulse	t _{PUMPX_ON2}		70	--	130	ms
Current Pulse Control Off Pulse	t _{PUMPX_OFF}		70	--	130	ms
Current Pulse Control Stop Start Delay	t _{PUMPX_DLY}		80	--	225	ms
I²C Characteristics						
Output Low Threshold Voltage	V _{OL_I²C}	I _{DS} = 10mA	--	--	0.4	V
SCL, SDA Input Logic High Threshold Voltage	V _{IH_I²C}		1.3	--	--	V
SCL, SDA Input Logic Low Threshold Voltage	V _{IL_I²C}		--	--	0.4	V
SCL Clock	f _{SCL}		--	--	400	kHz
High-Level Leakage Current	I _{BIRS}	V _{PULL_UP} = 1.8V, SDA and SCL	--	--	1	μA
Load Capacitance	C _{LOAD}	V _{PULL_UP} = 1.8V	--	--	1	pF
Default Wait Time for Watch Dog Reset	t _{WDT_DEF}	Watch dog timer selection, Default : 0x0D[6] = 1	--	500	--	ms
NTC Monitor						
Battery Temperature HOT Threshold	V _{VTS_HOT}	V _{TS} falling, the ratio of V _{REGN}	33.5	34.5	35.5	%

Parameter	Symbol	Test Conditions	Min	Typ	Max	Unit
Battery Temperature WARM Threshold	VVTS_WARM	V _{TS} falling, the ratio of V _{REGN}	44	45	46	%
Battery Temperature COOL Threshold	VVTS_COOL	V _{TS} rising, the ratio of V _{REGN}	67.5	68.5	69.5	%
Battery Temperature COLD Threshold	VVTS_COLD	V _{TS} rising, the ratio of V _{REGN}	72.5	73.5	74.5	%
Battery Temperature Hysteresis	VVTS_HYS		--	2	--	%
Control I/O Pin (INT)						
Output Low Voltage	V _{OL_CTRL}	I _{DS} = 10mA	--	--	0.4	V
Control I/O Pin (OTG, CEB, QON)						
Input Threshold Voltage	V _{IH_CTRL}	Logic high threshold	1.3	--	--	V
	V _{IL_CTRL}	Logic low threshold	--	--	0.4	
Battery Charge Detection Spec (D+/D-)						
VDP_SRC Voltage	V _{DP_SRC}	With I _{DAT_SRC} = 0 to 250μA	0.5	0.65	0.7	V
VDAT_REF Voltage	V _{DAT_REF}		0.25	0.325	0.4	V
VLGC Voltage	V _{LGC}		0.8	1.2	2	V
IDM SINK Current	I _{DM_SINK}	May be a resistance if desired	50	100	150	μA
Data Contact Timeout	t _{DCDT}	Setting by register 0x12[5:4]	--	600	--	ms
ADC						
ADC Conversion Time each Channel	t _{CONV}		35	200	--	ms
Number of Bits for ADC Resolution	RES	Logic high threshold	--	10	--	bit
ADC Accuracy and Measurement Range						
VBUS_DIV5 Measurement Range	V _{VBUS_DIV5ADC_Range}		1	--	22	V
VBUS_DIV5 Resolution	V _{VBUS_DIV5ADC_RES}		--	25	--	mV
VBUS_DIV5 Accuracy	V _{VBUS_DIV5ADC_ACC}		-2	--	2	LSB
VBUS_DIV2 Measurement Range	V _{VBUS_DIV2ADC_Range}		1	--	9.8	V
VBUS_DIV2 Resolution	V _{VBUS_DIV2ADC_RES}		--	10	--	mV
VBUS_DIV2 Accuracy	V _{VBUS_DIV2ADC_ACC}		-2	--	2	LSB
VBAT Measurement Range	V _{VBAT ADC_Range}		0	--	4.9	V
VBAT Resolution	V _{VBAT ADC_RES}		--	5	--	mV
VBAT Accuracy	V _{VBAT ADC_ACC}		-2	--	2	LSB
VSYS Measurement Range	V _{VSYS ADC_Range}		0	--	4.9	V

Parameter	Symbol	Test Conditions	Min	Typ	Max	Unit
VSYS Resolution	V _{VSYS} ADC_RES		--	5	--	mV
VSYS Accuracy	V _{VSYS} ADC_ACC		-2	--	2	LSB
REGN Measurement Range	V _{REGN} ADC_Range		0	--	4.9	V
REGN Resolution	V _{REGN} ADC_RES		--	5	--	mV
REGN Accuracy	V _{REGN} ADC_ACC		-2	--	2	LSB
TS_BAT Measurement Range	Rate _{TS_BAT}		0	--	100	%
TS_BAT Resolution	Rate _{TS_BAT} RES		--	0.25	--	%
TS_BAT Accuracy	Rate _{TS_BAT} ACC		-2	--	2	LSB
IBUS Measurement Range	I _{IBUS} ADC_Range		0	--	5	A
IBUS Resolution	I _{IBUS} ADC_RES		--	50	--	mA
IBUS Accuracy	I _{IBUS} ADC_ACC		-2	--	2	LSB
IBAT Measurement Range	I _{IBAT} ADC_Range		0	--	5	A
IBAT Resolution	I _{IBAT} ADC_RES		--	50	--	mA
IBAT Accuracy	I _{IBAT} ADC_ACC	I _{CHG} [5:0] setting ≥ 1000mA	-2	--	2	LSB
TEMP_JC Measurement Range	T _{TEMP_JC} ADC_Range		-40	--	120	°C
TEMP_JC Resolution	T _{TEMP_JC} ADC_RES		--	2	--	°C
TEMP_JC Accuracy	T _{TEMP_JC} ADC_ACC	Temperature < 85 °C	-2	--	2	LSB
VBATS Measurement Range	V _{VBATS} ADC_Range		0	--	4.9	V
VBATS Resolution	V _{VBATS} ADC_RES		--	5	--	mV
VBATS Accuracy	V _{VBATS} ADC_ACC		-2	--	2	LSB
TS_BUS Measurement Range	Rate _{TS_BUS}		0	--	100	%
TS_BUS Resolution	Rate _{TS_BUS} RES		--	0.25	--	%
TS_BUS Accuracy	Rate _{TS_BUS} ACC		-2	--	2	LSB
IBATS Measurement Range	I _{IBAT} ADC_Range		0	--	5	A
IBATS Resolution	I _{IBAT} ADC_RES		--	50	--	mA
IBATS Accuracy	I _{IBAT} ADC_ACC		-2	--	2	LSB
External N-MOSFET Selection Specification						
On-Resistance for DS Path	R _{DS(ON)}	V _{GS} = 4.5V	--	7	--	mΩ
Drain-to-Source Voltage (AMR)	V _{DS}		--	--	24	V
Gate-to-Source Voltage (AMR)	V _{GS}		-12	--	12	V
Continuous Drain Current	I _D	V _{GS} = 4.5V	8	10	--	A

Note 1. Stresses beyond those listed “Absolute Maximum Ratings” may cause permanent damage to the device. These are stress ratings only, and functional operation of the device at these or any other conditions beyond those indicated in the operational sections of the specifications is not implied. Exposure to absolute maximum rating conditions may affect device reliability.

Note 2. θ_{JA} is measured under natural convection (still air) at $T_A = 25^\circ\text{C}$ with the component mounted on a high effective-thermal-conductivity four-layer test board on a JEDEC 51-7 thermal measurement standard. θ_{JC} is measured at the exposed pad of the package.

Note 3. Devices are ESD sensitive. Handling precaution is recommended.

Note 4. The device is not guaranteed to function outside its operating conditions.

Typical Operating Characteristics

CV vs. Temperature

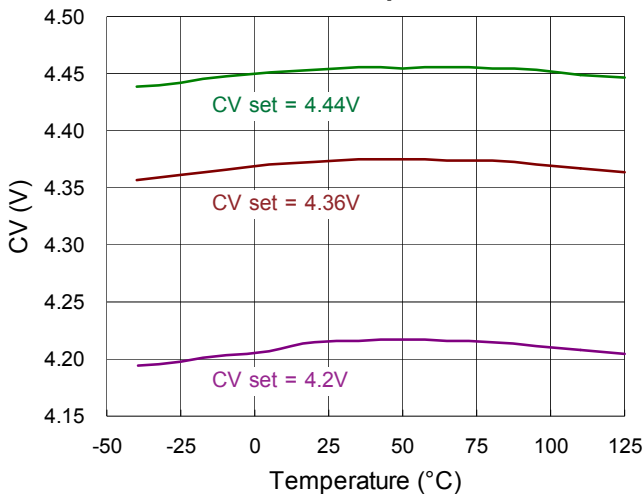

Charging Current vs. VBAT

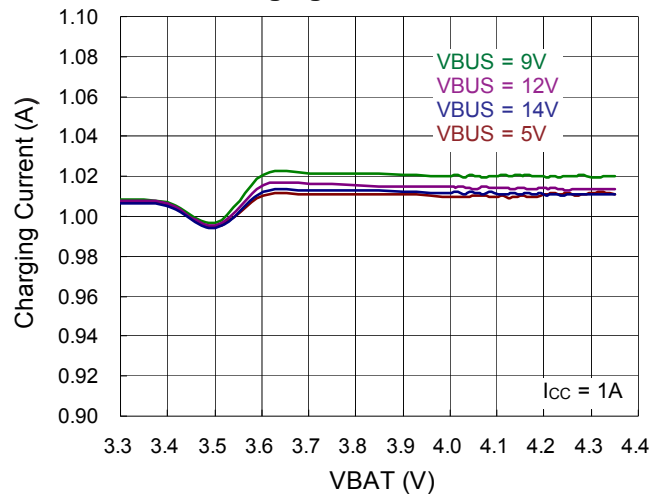

Boost Efficiency vs. Load Current

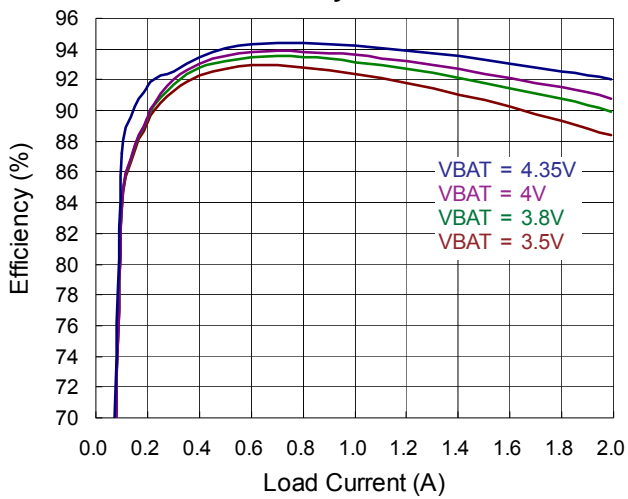

Charger Efficiency vs. Charging Current

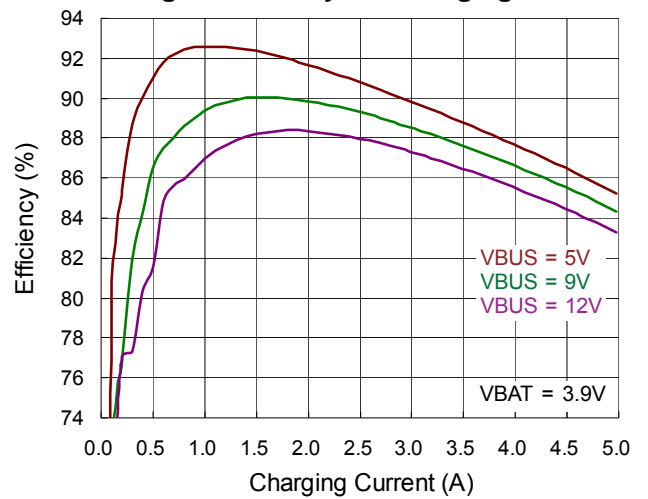

Register Description

I²C Slave Address : 1011100 (5CH)

Name		Function	Addr	Reset
CORE_CTRL0		Control 0	0x00	0x00
Bit	Mode	Name	Reset Value	Description
7	R/W	RST_REG	0	All registers reset bit. 0: Don't reset all registers. 1: Reset all registers. (Notice: 1.This bit will be reset to "0" after reset procedure finish. 2. In high-impedance mode, this bit reset all registers after leave high-impedance mode.)
[6:0]	R/W	Reserved	0000000	Reserved

Name		Function	Addr	Reset
CHG_CTRL1		Control 1	0x01	0x10
Bit	Mode	Name	Reset Value	Description
7	R/W	SEL_SWFREQ	0	The switching frequency selection bit (Charger/OTG) 0 : The switching frequency is 1.5MHz. (Default) 1 : The switching frequency is 0.75MHz.
6	R/W	FIXFREQ	0	Charger switching frequency 0 : Charger switching frequency would be varied if VBUS is closed to VBAT(default) 1 : Charger switching frequency is fixed
5	R/W	Reserved	0	Reserved
4	R/W	STAT_EN	1	Charger STAT pin function 0 : Disable 1 : Enable (default)
3	R/W	IRQ_PULSE	0	IRQ reminder function 0 : IRQ reminder is disabled (default) 1 : IRQ reminder is enabled. If IRQ is triggered but no check action, INT pin will be released as well as being triggered again with every 2s intervals
2	R/W	HZ	0	High-impedance selection 0 : No high-impedance mode (default) 1 : High-impedance mode
1	R/W	OTG_PIN_EN	0	Boost mode enable with OTG pin 0 : Enable Boost mode by OPA_MODE (default) 1 : Enable Boost by both OPA_MODE bit and OTG pin
0	R/W	OPA_MODE	0	Boost mode enable 0 : Charge mode (default) 1 : Boost mode for OTG

Name		Function	Addr	Reset
CHG_CTRL2		Charger Control 2	0x02	0x07
Bit	Mode	Name	Reset Value	Description
7	R/W	SHIP_MODE	0	Shipping mode enable, force BATFET OFF 0 : Allow BATFET turn on (default) 1 : Force BATFET turn off
6	R/W	BATDET_DIS_DLY	0	BATFET turn off delay 0 : BATFET turn off immediately (default) 1 : BATFET turn off with 10s delay after SHIP_MODE bit is set
5	R/W	BYPASS_MODE	0	"Bypass mode enable, disable the buck but force BATFET on 0 : Bypass mode disable (default) 1 : Bypass mode enable"
4	R/W	TE	0	Termination enable 0 : Disable charge current termination (default) 1 : Enable charge current termination
[3:2]	R/W	IINLMTSEL	01	Input current limit selection bit 00 : Input limit is set as 3.25A 01 : CHG_TYP results is applied D+D- detection (default) 10 : IAICR[5:0] results is applied 11 : Input limit is set by the lowest among above
1	R/W	CFO_EN	1	Charger and OTG enable 0 : CFO is disabled 1 : CFO is enabled (default)
0	R/W	CHG_EN	1	Charger enable 0 : Charger is disabled 1 : Charger is enabled (default)

Name		Function	Addr	Reset
CHG_CTRL3		Control 3	0x03	0x23
Bit	Mode	Name	Reset Value	Description
[7:2]	R/W	IAICR[5:0]	001000	AICR setting 000000 : 100mA 000001 : 150mA 000010 : 200mA 000011 : 250mA ... 001000 : 500mA (default) 001001 : 550mA ... 100110 : 2A ... 111010 : 3A ... 111111 : 3.25A
1	R/W	AICR_EN	1	AICR loop enable 0 : AICR loop disable 1 : AICR loop enable (default)
0	R/W	ILIM_EN	1	ILIM function enable 0 : ILIM function disable 1 : ILIM function enable (default)

Name		Function	Addr	Reset
CHG_CTRL4		Control 4	0x04	0x3C
Bit	Mode	Name	Reset Value	Description
[7:1]	R/W	VOREG[6:0]	0011110	Battery regulation voltage. The battery regulation voltage step is 10mV. 0000000 : 3.9V 0000001 : 3.91V 0000010 : 3.92V 0000011 : 3.93V ... 0011101 : 4.19V 0011110 : 4.2V (default) 0011111 : 4.21V ... 0101100 : 4.34V 0101101 : 4.35V 0101110 : 4.36V ... 1010001 : 4.71V 1010001 ~ 1111111 : 4.71V
0	R/W	Reserved	0	Reserved

Name		Function	Addr	Reset
CHG_CTRL5		Control 5	0x05	0x67
Bit	Mode	Name	Reset Value	Description
[7:2]	R/W	VOTGBST[5:0]	011001	OTG boost-mode output regulation voltage. The OTG regulation voltage step is 25mV. 000000 : 4.425V 000001 : 4.45V 000010 : 4.475V ... 010111 : 5V 011000 : 5.025V 011001 : 5.05V (default) 011010 : 5.075V 011011 : 5.1V ... 111000 : 5.825V 111001 to 111111 : 5.825V
[1:0]	R/W	THREG[1:0]	11	Charger thermal regulation threshold 00 : 60°C 01 : 80°C 10 : 100°C 11 : 120°C (default)

Name		Function	Addr	Reset
CHG_CTRL6		Control 6	0x06	0x0B
Bit	Mode	Name	Reset Value	Description
[7:1]	R/W	VMIVR[6:0]	0000101	Input MIVR threshold setting 0000000 : 3.9V 0000001 : 4V 0000010 : 4.1V 0000011 : 4.2V 0000100 : 4.3V 0000101 : 4.4V (default) 0000110 : 4.5V ... 0011110 : 6.9V 0011111 : 7V ... 0110010 : 8.9V 0110011 : 9V ... 1010000 : 11.9V 1010001 : 12V ... 1011111 : 13.4V 1100000 to 1111111 : 13.4V
0	R/W	MIVR_EN	1	MIVR loop enable 0 : MIVR loop disable 1 : MIVR loop enable (default)

Name		Function	Addr	Reset
CHG_CTRL7		Control 7	0x07	0x4C
Bit	Mode	Name	Reset Value	Description
[7:2]	R/W	ICHG[5:0]	010011	Charging regulation current 000000 : 0.1A 000001 : 0.2A 000010 : 0.3A ... 001000 : 0.9A 001001 : 1A 001010 : 1.1A ... 010010 : 1.9A 010011 : 2A (default) ... 011100 : 2.9A 011101 : 3A ... 100110 : 3.9A 100111 : 4A ... 110000 : 4.9A 110001 : 5A 110010 to 111111 : 5A Note : When ICHG is set above 2.5A, recommend the OCP to set higher level. (Addr 0x0D[2] = 1)
[1:0]	R/W	EOC_TIMER[1:0]	00	EOC back-charge time 00 : 0mins (default) 01 : 30mins 10 : 45mins 11 : 60mins

Name		Function	Addr	Reset
CHG_CTRL8		Control 8	0x08	0xA1
Bit	Mode	Name	Reset Value	Description
[7:4]	R/W	VPREC[3:0]	1010	Pre-charge voltage threshold 0000 : 2V 0001 : 2.1V 0010 : 2.2V 0011 : 2.3V 0100 : 2.4V 0101 : 2.5V 0110 : 2.6V 0111 : 2.7V 1000 : 2.8V 1001 : 2.9V 1010 : 3.0V (default) 1011 : 3.1V 1100 : 3.2V 1101 : 3.3V 1110 : 3.4V 1111 : 3.5V
[3:0]	R/W	IPREC[3:0]	0001	Pre-charge current threshold 0000 : 100mA 0001 : 150mA (default) 0010 : 200mA 0011 : 250mA 0100 : 300mA 0101 : 350mA 0110 : 400mA 0111 : 450mA 1000 : 500mA 1001 : 550mA 1010 : 600mA 1011 : 650mA 1100 : 700mA 1101 : 750mA 1110 : 800mA 1111 : 850mA

Name		Function	Addr	Reset
CHG_CTRL9		Control 9	0x09	0x3C
Bit	Mode	Name	Reset Value	Description
[7:4]	R/W	IEOC[3:0]	0011	EOC current setting 0000 : 100mA 0001 : 150mA 0010 : 200mA 0011 : 250mA (default) 0100 : 300mA 0101 : 350mA 0110 : 400mA 0111 : 450mA 1000 : 500mA 1001 : 550mA 1010 : 600mA 1011 : 650mA 1100 : 700mA 1101 : 750mA 1110 : 800mA 1111 : 850mA
3	R/W	EOC_EN	1	IEOC enable/disable 0: Disable 1: Enable (default)
[2:0]	R/W	CHG_TDEG_EOC[2:0]	100	EOC deglitch time 000 : 32μs 001 : 64μs 010 : 128μs 011 : 256μs 100 : 2ms (default) 101 : 4ms 110 : 8ms 111 : 16ms

Name		Function	Addr	Reset
CHG_CTRL10		Control 10	0x0A	0x58
Bit	Mode	Name	Reset Value	Description
[7:4]	R/W	OTG_LBP[3:0]	0101	OTG Low battery protection voltage selection (falling edge threshold, hysteresis voltage = 0.4V) 0000 : 2.3V 0001 : 2.4V 0010 : 2.5V 0011 : 2.6V 0100 : 2.7V 0101 : 2.8V (default) 0110 : 2.9V 0111 : 3.0V 1000 : 3.1V 1001 : 3.2V 1010 : 3.3V 1011 : 3.4V 1100 : 3.5V 1101 : 3.6V 1110 : 3.7V 1111 : 3.8V
3	R/W	OTG_LBP_EN	1	OTG low-battery protection (LBP) enable/disable 0 : Disable 1 : Enable (default)
[2:0]	R/W	OTG_OLP[2:0]	000	OTG over-load threshold (Minimum) 000 : 0.5A (default) 001 : 0.7A 010 : 1.1A 011 : 1.3A 100 : 1.8A 101 : 2.1A 110 : 2.4A 111 : Reserved Note : When OTG_OLP is set 2.1A or 2.4A, recommend the OCP to set higher level. (Addr 0x0D[2] = 1)

Name		Function	Addr	Reset
CHG_CTRL11		Control 11	0x0B	0x2C
Bit	Mode	Name	Reset Value	Description
7	R/W	ADP_DIS	0	Charger adapter-detection disable 0 : Adapter-detection is enabled (default) 1 : Adapter-detection is disabled
6	R/W	BATD_EN	0	Charger battery-detection when charge done 0 : Battery-detection is disabled (default) 1 : Battery-detection is enabled
5	R/W	SYSUV_HW_SEL	1	System under-voltage protection (UVP) selection bit 0 : Buck switching is not turned off when system UVP occurs 1 : Buck switching is turned off when system UVP occurs (default)
[4:2]	R/W	SYSREG[2:0]	011	Minimum system regulation voltage 000 : 3.3V 001 : 3.4V 010 : 3.5V 011 : 3.6V (default) 100 : 3.7V 101 : 3.8V 110 : 3.9V 111 : 4.0V
[1:0]	R/W	VRECH	00	Recharge voltage threshold with VOREG 00 : 100mV (default) 01 : 200mV 10 : 300mV 11 : 400mV

Name		Function	Addr	Reset
CHG_CTRL12		Control 12	0x0C	0x02
Bit	Mode	Name	Reset Value	Description
[7:5]	R/W	WT_FC[2:0]	000	Fast charge timer 000 : 4hrs (default) 001 : 6hrs 010 : 8hrs 011 : 10hrs 100 : 12hrs 101 : 14hrs 110 : 16hrs 111 : 20hrs
[4:3]	R/W	WT_PRC[1:0]	00	Pre-charge timer 00 : 30mins (default) 01 : 45mins 10 : 60mins 11 : 60mins
2	R/W	TMR2X_EN	0	Double charger timer during MIVR, AICR, and thermal regulation 0 : Disable 2x extended charger timer (default) 1 : Enable 2x extended charger timer
1	R/W	TMR_EN	1	Charger timer enable/disable 0 : Disable 1 : Enable (default)
0	R/W	TMR_PAUSE	0	Timer control bit 0 : Timer is active (default) 1 : Timer is paused

Name		Function	Addr	Reset
CHG_CTRL13		Control 13	0x0D	0x52
Bit	Mode	Name	Reset Value	Description
7	R/W	WDT_EN	0	Watch dog timer enable/disable 0 : Disable (default) 1 : Enable
6	R/W	WDT_TRST	1	Waiting timer to reset I ² C setup after watchdog is asserted 0 : 200ms 1 : 500ms (default)
[5:4]	R/W	WDT[1:0]	01	Watch dog timer, from WDTEN is enabled to watchdog IRQ 00 : 8s 01 : 40s (default) 10 : 80s 11 : 160s
3	R/W	AJITA	0	Charge current setting for JEITA 0 : ICHG value is kept (default) 1 : ICHG value is half of the default value
2	R/W	OCP	0	Inductor OCP current level for both buck and boost modes 0 : OCP = 6A (default) 1 : OCP = 8A
1	R/W	UUG_ON	1	UUG enable/disable control 0 : Force UUG turn off 1 : Allow UUG turn on (default)
0	R/W	INT_REZ	0	INT pin re-trigger control. Any event triggers but system does not check 0 : No action (default) 1 : Release INT pin, then will re-triggers after 2ms if any event exists (this bit will auto reset to 0 when the re-trigger is done)

Name		Function	Addr	Reset
CHG CTRL 14		Charger Control 14	0x0E	0x05
Bit	Mode	Name	Reset Value	Description
7	R/W	AICL_MEAS	0	AICL measurement mechanism 0 : No operation (default) 1 : Execute AICL measurement
[6:5]	R/W	TDEG_AICL_MEAS[1:0]	00	Comparator output deglitch time 00 : 2ms (default) 01 : 4ms 10 : 8ms 11 : 16ms
[4:3]	R/W	AICL_MAX_MEAS_INTVL	00	Detection internal time 00 : 50ms (default) 01 : 100ms 10 : 200ms 11 : 400ms
[2:0]	R/W	AICL_VTH[2:0]	101	Detection comparator threshold 000 : 4.1V 001 : 4.2V 010 : 4.3V 011 : 4.4V 100 : 4.5V 101 : 4.6V (default) 110 : 4.7V 111 : 4.8V

Name		Function	Addr	Reset
CHG CTRL 15		Charger Control 15	0x0F	0x02
Bit	Mode	Name	Reset Value	Description
7	R/W	ICHG_MEAS	0	ICHG measurement mechanism 0 : No operation (default) 1 : Execute ICHG measurement
[6:3]	R	ICHG_RPT[3:0]	0000	Report the ICHG measurement result 0000 : 100mA 0001 : 150mA 0010 : 200mA 0011 : 250mA 0100 : 300mA 0101 : 350mA 0110 : 400mA 0111 : 450mA 1000 : 500mA 1001 : 550mA 1010 : 600mA 1011 : 650mA 1100 : 700mA 1101 : 750mA 1110 : 800mA 1111 : 850mA
2	R/W	Reserved	0	Reserved
1	R/W	IBATS_R_SEL	1	Off-chip current sensing resistor setting (IBAT_SP and IBAT_SN) 0 : 5mΩ 1 : 10mΩ
0	R/W	Reserved	0	Reserved

Name		Function	Addr	Reset
CHG CTRL 16		Charger Control 16	0x10	0x10
Bit	Mode	Name	Reset Value	Description
[7:5]	R/W	Reserved	000	Reserved
4	R/W	JEITA_EN	1	JEITA function enable/disable 0 : Disable 1 : Enable (default)
3	R/W	JEITA_COOL_ISET	0	JEITA current setting in COOL region 0 : Set Charge Current to ICHG/2 (default) 1 : Set Charge Current to ICHG
2	R/W	JEITA_WARM_ISET	0	JEITA current setting in WARM region 0 : Set Charge Current to ICHG/2 (default) 1 : Set Charge Current to ICHG
1	R/W	JEITA_COOL_VSET	0	JEITA voltage setting in COOL region 0 : Set Charge Voltage to VOREG-0.2V (default) 1 : Set Charge Voltage to VOREG
0	R/W	JEITA_WARM_VSET	0	JEITA voltage setting in WARM region 0 : Set Charge Voltage to VOREG-0.2V (default) 1 : Set Charge Voltage to VOREG

Name		Function	Addr	Reset
CHG ADC		ADC	0x11	0x00
Bit	Mode	Name	Reset Value	Description
[7:4]	R/W	ADC_IN_SEL[3:0]	0000	ADC channel selection 0000 : Reserved (default) 0001 : VBUS/5 0010 : VBUS/2 0011 : VSYS 0100 : VBAT 0101 : VBATS 0110 : TS_BAT 0111 : TS_BUS 1000 : IBUS 1001 : IBAT 1010 : IBATS 1011 : REGN 1100 : TEMP_JC 1101 to 1111 : Reserved
[3:1]	R/W	Reserved	000	Reserved
0	R/W	ADC_START	0	ADC start control 0 : ADC conversion not active (default) 1 : Start ADC conversion (auto clear when conversion done)

Name		Function	Addr	Reset
CHG DPDM1		DPDM1	0x12	0xD0
Bit	Mode	Name	Reset Value	Description
7	R/W	USBCHGEN	1	USB charger detection flow enable/disable 0: Disable USB charger detection flow 1: Enable USB charger detection flow (default)
6	R/W	Reserved	1	Reserved
[5:4]	R/W	DCD_TIMEOUT	01	Data contact detection timeout 00 : 300ms 01 : 600ms (default) 10 : 900ms 11 : 1200ms
3	R	Reserved	0	Reserved
2	R	DCP STD	0	Report of the standard DCP detection 0 : Standard DCP is not detected (default) 1 : Standard DCP is detected
1	R	CDP	0	Report of the charging downstream port detection 0 : Charging downstream port is not detected (default) 1 : Charging downstream port is detected
0	R	SDP	0	Report of the standard USB port detection 0 : Standard USB port is not detected (default) 1 : Standard USB port is detected

Name		Function	Addr	Reset
CHG DPDM2		DPDM2	0x13	0x20
Bit	Mode	Name	Reset Value	Bit
[7:5]	R/W	Reserved	001	Reserved
[4:3]	R	Reserved	00	Reserved
[2:0]	R	USB Status	000	USB status 000 : No VBUS (default) 001 : VBUS flow is under going 010 : SDP (sSDPORT_CHD = 1 & DCDT=0) 011 : SDP NSTD (sSDPORT_CHD = 1 & DCDT = 1) 100 : DCP (sDCPORT_CHD = 1) 101 : CDP (sCDPORT_CHD = 1)

Name		Function	Addr	Reset
CHG DPDM3		DPDM3	0x14	0x20
Bit	Mode	Name	Reset Value	Description
[7:2]	R/W	Reserved	001000	Reserved
1	R	DCDT_STATUS	0	Data contact timeout status 0 : Data contact timeout is not expired 1 : Date contact timeout is expired
0	R	CHGDET_STATUS	0	BC detection output 0 : Charger port (DCP and CDP) is not detected 1 : Charger port (DCP and CDP) is detected

Name		Function	Addr	Reset
CHG_PUMP		PUMP	0x18	0x20
Bit	Mode	Name	Reset Value	Description
7	R/W	PPOFF_RST_DIS	0	System reset function disable bit 0 : System reset enable (default) 1 : System reset disable
[6:2]	R/W	Reserved	001000	Reserved
1	R/W	VG_LVL_SEL	0	Charge pump pumping level selection 0 : 5V (default) 1 : 10V
0	R/W	VG_EN	0	Charge pump enable/disable 0 : Disable (default) 1 : Enable

Name		Function	Addr	Reset
CHG_CTRL17		Charger Control 17	0x19	0x00
Bit	Mode	Name	Reset Value	Description
7	R/W	EN_PUMPX	0	Enable MTK pump express pulse 0 : Disable (default) 1 : Allow MTK pump express pulse
6	R/W	PUMPX_2.0_1.0	0	MTK pump express 2.0 / 1.0 enable 0 : PE1.0 Enable (default) 1 : PE 2.0 Enable
5	R/W	PUMPX_UP_DN	0	MTK pump express 1.0 voltage up/down enable 0 : PE 1.0 voltage down enable (default) 1 : PE 1.0 voltage up enable
[4:0]	R/W	PUMPX_DEC	00000	MTK pump express 2.0 voltage request setting 00000 : 5.5V (default) 00001 : 6V 00010 : 6.5V ... 00111 : 9V ... 01101 : 12V 01110 : 12.5V 01111 : 13V 10000 : 13.5V 10001 : 14V 10010 : 14.5V 10011 : Reserved ... 11101 : Reserved 11110 : Adapter healthy self-testing 11111 : Disable cable drop compensation

Name		Function	Addr	Reset
CHG_CTRL18		Charger Control 18	0x1A	0x40
Bit	Mode	Name	Reset Value	Description
[7:6]	R/W	Reserved	01	Reserved
[5:3]	R/W	BAT_COMP	000	Battery IR compensation resistor setting 000 : 0mΩ (default) 001 : 25mΩ 010 : 50mΩ 011 : 75mΩ 100 : 100mΩ 101 : 125mΩ 110 : 150mΩ 111 : 175mΩ
[2:0]	R/W	VCLAMP	000	Battery IR compensation maximum voltage clamp 000 : 0mV (default) 001 : 32mV 010 : 64mV 011 : 96mV 100 : 128mV 101 : 160mV 110 : 192mV 111 : 224mV

Name		Function	Addr	Reset
CHG_DIRCHG1		DIRCHG1	0x1B	0x58
Bit	Mode	Name	Reset Value	Description
7	R/W	sDIRCHG_UC_EN	0	Direct charge under-current (UC) protection enable 0 : Disable (default) 1 : Enable
6	R/W	sDIRCHG_OV_EN	1	Direct charge over-voltage protection enable 0 : Disable 1 : Enable (default)
[5:4]	R/W	sDIRCHG_OV_LVL[1:0]	01	Direct battery OVP protection level selection 00 : 104% of VOREG 01 : 108% of VOREG (default) 10 : 119% of VOREG 11 : Disable
3	R/W	sDIRCHG_OC_EN	1	Direct charge over-current (OC) protection enable 0 : Disable 1 : Enable (default)
[2:0]	R/W	sDIRCHG_OC_LVL[2:0]	000	Direct charge over-current protection level setting 000 : 4A (default) 001 : 4.5A 010 : 5A 011 : 5.5A 100 : 6A 101~111 : 6.5A

Name		Function	Addr	Reset
CHG_DIRCHG2		DIRCHG2	0x1C	0xB1
Bit	Mode	Name	Reset Value	Description
7	R/W	DIRCHG_WDT_TRST	1	Waiting timer to disable direct charge path after watchdog is asserted 0 : 200ms 1 : 500ms (default)
[6:4]	R/W	DIRCHG_WDT[2:0]	011	Direct charge watch dog timer setting: 000 : Disable 001 : 0.125s 010 : 0.25s 011 : 0.5s (default) 100 : 1s 101 : 2s 110 : 4s 111 : 8s
[3:2]	R/W	DIRCHG_VDEG[1:0]	00	Direct charge OV protection deglitch time 00 : 0us (default) 01 : 2us 10 : 8us 11 : 16us
[1:0]	R/W	DIRCHG_IDEG[1:0]	01	Direct charge OC and UC protection deglitch time 00 : 0ms 01 : 1ms (default) 10 : 5ms 11 : 10ms

Name		Function	Addr	Reset
CHG_DIRCHG3		DIRCHG3	0x1D	0x24
Bit	Mode	Name	Reset Value	Description
7	R/W	sDIRCHG_VBUSOV_EN	0	Direct charge VBUSOV protection enable 0 : Disable (default) 1 : Enable
[6:2]	R/W	sDIRCHG_VBUSOV_LVL[4:0]	01001	Direct charge VBUSOV protection level 00000 : 3.9V 00001 : 4.0V 00110 : 4.5V 00111 : 4.6V 01000 : 4.7V 01001 : 4.8V (default) 11110 : 6.9V 11111 : 7.0V
[1:0]	R/W	Reserved	00	Reserved

Name		Function	Addr	Reset
DEVICE_ID		DEVICE_ID	0x40	0xA3
Bit	Mode	Name	Reset Value	Description
[7:4]	R	VENDOR[3:0]	1010	Vendor IC
[3:0]	R	CHIP_REV[3:0]	0011	Chip version : 0001 = A, 0010 = B, 0011 = C...etc

Name		Function	Addr	Reset
CHG_STAT		CHG_STAT	0x42	0x00
Bit	Mode	Name	Reset Value	Description
[7:6]	R	CHG_STAT	00	Charger status bit 00 : Ready 01 : Charge in progress 10 : Charge done 11 : Fault
5	R	VBAT_LVL	0	Battery voltage level for operation mode 0 : Charger operate in pre-charge 1 : Charger operate in fast-charge level
4	R	VBAT_TRICKLE	0	Battery voltage level for operation mode 0 : Charger does not operate in trickle level 1 : Charger operates in trickle level
3	R	BOOST_STAT	0	Boost mode status 0 : Not in boost mode 1 : in boost mode
2	R	BST_VBUSOV_STAT	0	Boost mode VBUS over-voltage protection (VBUS OVP) status 0 : Boost VBUS OVP does not occur 1 : Boost VBUS OVP occurs
1	R	DIRCHG_FAULT	0	Direct charge fault status 0 : Fault does not occurs in direct charge mode 1 : Fault occurs in direct charge mode
0	R	ADC_STAT	0	ADC status 0 : ADC is idle 1 : ADC is under conversion

Name		Function	Addr	Reset
CHG_NTC		CHG NTC	0x43	0x00
Bit	Mode	Name	Reset Value	Description
7	R	Reserved	0	Reserved
[6:4]	R	BAT_NTC_FAULT[2:0]	000	BAT NTC fault status 000 : Normal 010 : Warm 011 : Cool 101 : Cold 110 : Hot
3	R	Reserved	0	Reserved
[2:0]	R	BUS_NTC_FAULT[2:0]	000	BUS NTC fault status 000 : Normal 010 : Warm 011 : Cool 101 : Cold 110 : Hot

Name		Function	Addr	Reset
ADC_DATA_H		ADC DATA H	0x44	0x00
Bit	Mode	Name	Reset Value	Description
[7:0]	R	ADC_CODEH[7:0]	00000000	ADC high-byte code

Name		Function	Addr	Reset
ADC_DATA_L		ADC DATA L	0x45	0x00
Bit	Mode	Name	Reset Value	Description
[7:0]	R	ADC_CODEL[7:0]	00000000	ADC low-byte code

Name		Function	Addr	Reset
CHG_STATC		CHG_STATC	0x50	0x00
Bit	Mode	Name	Reset Value	Description
7	R	PWR_RDY	0	Power ready status bit 0 : Input power is bad, VBUS > VOVP or VBUS < VUVLO or VBUS < BATS + VSLP 1 : Input power is good, UVLO < VBUS < VOVP & VBUS > BATS + VSLP
6	R	CHG_MIVR	0	Charger warning status. Input voltage MIVR loop active. 0 : MIVR loop is not active 1 : MIVR loop is active
5	R	CHG_AICR	0	Charger warning status. Input current AICR loop active. 0 : AICR loop is not active 1 : AICR loop is active
4	R	CHG_TREG	0	Charger warning. Thermal regulation loop active. 0 : Thermal regulation loop is not active 1 : Thermal regulation loop is active
[3:1]	R	Reserved	000	Reserved
0	R	DIRCHG_ON	0	Direct charge path on/off status 0 : Direct charge path is off 1 : Direct charge path is on

Name		Function	Addr	Reset
CHG_FAULT		CHG_FAULT	0x51	0x00
Bit	Mode	Name	Reset Value	Description
7	R	CHG_VBUSOV	0	VBUS over-voltage protection. Set when VBUS > VBUS_OVP is detected. 0 : VBUS is not over voltage 1 : VBUS is over voltage
6	R	CHG_VBATOV	0	Charger fault. Battery OVP. 0 : Battery is not OVP 1 : Battery is OVP
5	R	CHG_VSYSOV	0	Charger fault. System OVP. 0 : System is not OVP 1 : System is OVP
4	R	CHG_VSYSUV	0	Charger fault. System UVP. 0 : System is not UVP 1 : System is UVP
[3:0]	R	Reserved	0000	Reserved

Name		Function	Addr	Reset
TS_STATC		TS_STATC	0x52	0x00
Bit	Mode	Name	Reset Value	Description
7	R	TS_BAT_HOT	0	BAT temperature status indication 0 : Normal temperature 1 : Temperature is hot
6	R	TS_BAT_WARM	0	BAT temperature status indication 0 : Normal temperature 1 : Temperature is warm
5	R	TS_BAT_COOL	0	BAT temperature status indication 0 : Normal temperature 1 : Temperature is cool
4	R	TS_BAT_COLD	0	BAT temperature status indication 0 : Normal temperature 1 : Temperature is cold
3	R	TS_BUS_HOT	0	BUS temperature status indication 0 : Normal temperature 1 : Temperature is hot
2	R	TS_BUS_WARM	0	BUS temperature status indication 0 : Normal temperature 1 : Temperature is warm
1	R	TS_BUS_COOL	0	BUS temperature status indication 0 : Normal temperature 1 : Temperature is cool
0	R	TS_BUS_COLD	0	BUS temperature status indication 0 : Normal temperature 1 : Temperature is cold

Name		Function	Addr	Reset
CHG_IRQ1		CHG IRQ 1	0x53	0x00
Bit	Mode	Name	Reset Value	Description
7	R/C	OTPI	0	Thermal shutdown fault 0 : No operation 1 : Event occurs
6	R/C	CHG_RVPI	0	Charger reverse protection fault 0 : No event occurs 1 : Event occurs
5	R/C	CHG_ADPBADI	0	Charger bad adapter fault 0 : No event occurs 1 : Event occurs
4	R/C	CHG_BATABSI	0	Battery absence fault 0 : No event occurs 1 : Event occurs
3	R/C	CHG_TMRI	0	Charger timer time-out fault 0 : No event occurs 1 : Event occurs
2	R/C	CHG_STATCI	0	Status of each CHG_STATC register (Reg0x50) is changed 0 : No event occurs 1 : Event occurs
1	R/C	CHG_FAULTI	0	Status of each CHG_FAULT register (Reg0x51) is changed 0 : No event occurs 1 : Event occurs
0	R/C	TS_STATCI	0	Status of each TS_STATC register (Reg0x52) is changed 0 : No event occurs 1 : Event occurs

Name		Function	Addr	Reset
CHG_IRQ2		CHG IRQ 2	0x54	0x00
Bit	Mode	Name	Reset Value	Description
7	R/C	CHG_IEOCI	0	Charging current is lower than EOC current ever occurs 0 : No event occurs 1 : Event occurs
6	R/C	CHG_TERMI	0	Charge terminated event 0 : No event occurs 1 : Event occurs
5	R/C	CHG_RECHGI	0	Re-Charge behavior ever occurs. 0 : No event occurs 1 : Event occurs
4	R/C	SSFINISHI	0	Charger or boost-mode soft-start finishes event 0 : no event occurs 1 : event occurs
3	R/C	WDTMRI	0	Watch dog timer timeout fault 0 : No event occurs 1 : Event occurs
2	R/C	CHGDET_DONEI	0	Charger-type detection done event 0 : No event occurs 1 : Event occurs
1	R/C	CHG_ICHGMeasI	0	ICHG measurement function done event 0 : No event occurs 1 : Event occurs
0	R/C	CHG_AICLMeasI	0	AICL measurement function done event 0 : No event occurs 1 : Event occurs

Name		Function	Addr	Reset
CHG_IRQ3		CHG IRQ 3	0x55	0x00
Bit	Mode	Name	Reset Value	Description
7	R/C	BST_OLPI	0	Boost over-load protection event 0 : No event occurs 1 : Event occurs
6	R/C	BST_MIDОВI	0	Boost PMID OVP fault event 0 : No event occurs 1 : Event occurs
5	R/C	BST_BATUVI	0	Boost low voltage input fault event 0 : No event occurs 1 : Event occurs
[4:2]	R/W	Reserved	000	Reserved
1	R/C	PUMPX_DONEI	0	MTK pump express function done event 0 : No event occurs 1 : Event occurs
0	R/C	ADC_DONEI	0	ADC measurement done event 0 : No event occurs 1 : Event occurs

Name		Function	Addr	Reset
DPDM_IRQ		DPDM IRQ	0x56	0x00
Bit	Mode	Name	Reset Value	Description
7	R/C	DCDTI	0	Data contact detection event 0 : Data Contact Detection timeout is not detected 1 : Data Contact Detection timeout is detected when DCDT goes from 0 to 1
6	R/C	CHGDETI	0	Output of USB charger detection. The bit will be set to 1 if COMN > VDAT_REF & COMN < VLGC 0 : COMN < VDAT_REF or COMN > VLGC (charger port is not detected) 1 : COMN > VDAT_REF & COMN < VLGC (charger port is detected) when CHGDET goes from 0 to 1
5	R/C	HVDCP DETI	0	HVDCP detect event 0 : HVDCP not detected by DCP's pulling D- to GND 1 : HVDCP detected by DCP's pulling D- to GND
[4:2]	R/C	Reserved	000	Reserved
1	R/C	Detach_I	0	VBUS detach, when VBUSPG_D goes from 1 to 0 0 : No event occurs 1 : Event occurs
0	R/C	Attach_I	0	VBUS attach, when DCP STD (Reg0x12[2]) goes from 0 to 1 or when CDP (Reg0x12[1]) goes from 0 to 1 or when SDP (Reg0x12[0]) goes from 0 to 1 0 : No event occurs 1 : Event occurs

Name		Function	Addr	Reset
DPDM_IRQ		DPDM IRQ	0x58	0x00
Bit	Mode	Name	Reset Value	Description
7	R/C	DIRCHG_OVI	0	Direct charge OV protection event 0 : No event occurs 1 : Event occurs
6	R/C	DIRCHG_OCI	0	Direct charge OC protection event 0 : No event occurs 1 : Event occurs
5	R/C	DIRCHG_UCI	0	Direct charge UC protection event 0 : No event occurs 1 : Event occurs
4	R/C	DIRCHG_WDTMRI	0	Direct charge watch dog timer event 0 : No event occurs 1 : Event occurs
3	R/C	DIRCHG_VGOKI	0	Direct charge path ready indicator event 0 : No event occurs 1 : Direct charge path is ready
2	R/C	DIRCHG_VBUSOVI	0	Direct charge VBUS OV protection event 0 : No event occurs 1 : Event occurs
[1:0]	R/C	Reserved	000	Reserved

Name		Function	Addr	Reset
CHG_STATC_CTRL		CHG STATC CTRL	0x60	0xFF
Bit	Mode	Name	Reset Value	Description
7	R/W	PWR_RDYM	1	Power ready interrupt mask 0 : Interrupt is not masked 1 : Interrupt is masked
6	R/W	CHG_MIVRM	1	Input voltage MIVR loop active interrupt mask 0 : Interrupt is not masked 1 : Interrupt is masked
5	R/W	CHG_AICRM	1	Input current AICR loop active interrupt mask 0 : Interrupt is not masked 1 : Interrupt is masked
4	R/W	CHG_TREGM	1	Thermal regulation loop active interrupt mask 0 : Interrupt is not masked 1 : Interrupt is masked
[3:1]	R/W	Reserved	111	Reserved
0	R	DIRCHG_ONM	1	Direct charge path on/off interrupt mask 0 : Interrupt is not masked 1 : Interrupt is masked

Name		Function	Addr	Reset
CHG_FAULT_CTRL		CHG FAULT CTRL	0x61	0xF0
Bit	Mode	Name	Reset Value	Description
7	R/W	CHG_VBUSOVM	1	VBUS over-voltage protection interrupt mask 0 : Interrupt is not masked 1 : Interrupt is masked
6	R/W	CHG_VBATOVM	1	Battery OVP interrupt mask 0 : Interrupt is not masked 1 : Interrupt is masked
5	R/W	CHG_VSYSOVM	1	System OVP interrupt mask 0 : Interrupt is not masked 1 : Interrupt is masked
4	R/W	CHG_VSYSUVM	1	System UVP interrupt mask 0 : Interrupt is not masked 1 : Interrupt is masked
[3:0]	R/W	Reserved	0000	Reserved

Name		Function	Addr	Reset
TS_STATC_CTRL		TS_STATC_CTRL	0x62	0xFF
Bit	Mode	Name	Reset Value	Description
7	R/W	TS_BAT_HOTM	1	BAT temperature status interrupt mask 0 : Interrupt is not masked 1 : Interrupt is masked
6	R/W	TS_BAT_WARMM	1	BAT temperature status interrupt mask 0 : Interrupt is not masked 1 : Interrupt is masked
5	R/W	TS_BAT_COOLM	1	BAT temperature status interrupt mask 0 : Interrupt is not masked 1 : Interrupt is masked
4	R/W	TS_BAT_COLDM	1	BAT temperature status interrupt mask 0 : Interrupt is not masked 1 : Interrupt is masked
3	R/W	TS_BUS_HOTM	1	BUS temperature status interrupt mask 0 : Interrupt is not masked 1 : Interrupt is masked
2	R/W	TS_BUS_WARMM	1	BUS temperature status interrupt mask 0 : Interrupt is not masked 1 : Interrupt is masked
1	R/W	TS_BUS_COOLM	1	BUS temperature status interrupt mask 0 : Interrupt is not masked 1 : Interrupt is masked
0	R/W	TS_BUS_COLDM	1	BUS temperature status interrupt mask 0 : Interrupt is not masked 1 : Interrupt is masked

Name		Function	Addr	Reset
CHG_IRQ1_CTRL		CHG IRQ 1 CTRL	0x63	0xFF
Bit	Mode	Name	Reset Value	Description
7	R/W	OTPM	1	Thermal shutdown fault interrupt mask 0 : Interrupt is not masked 1 : Interrupt is masked
6	R/W	CHG_RVPM	1	Charger reverse protection fault interrupt mask 0 : Interrupt is not masked 1 : Interrupt is masked
5	R/W	CHG_ADPBADM	1	Charger bad adapter fault interrupt mask 0 : Interrupt is not masked 1 : Interrupt is masked
4	R/W	CHG_BATABSM	1	Battery absence fault interrupt mask 0 : Interrupt is not masked 1 : Interrupt is masked
3	R/W	CHG_TMRM	1	Charger timer time-out fault interrupt mask 0 : Interrupt is not masked 1 : Interrupt is masked
2	R/W	CHG_STATCM	1	Status of each CHG_STATC register (0x50) changed interrupt mask 0 : Interrupt is not masked 1 : Interrupt is masked
1	R/W	CHG_FAULTM	1	Status of each CHG_FAULT register (0x51) changed interrupt mask 0 : Interrupt is not masked 1 : Interrupt is masked
0	R/W	TS_STATCM	1	Status of each TS_STATC register (0x52) changed interrupt mask 0 : Interrupt is not masked 1 : Interrupt is masked

Name		Function	Addr	Reset
CHG_IRQ2_CTRL		CHG IRQ 2 CTRL	0x64	0xFF
Bit	Mode	Name	Reset Value	Description
7	R/W	CHG_IEOCM	1	Charging current is lower than EOC current interrupt mask 0 : Interrupt is not masked 1 : Interrupt is masked
6	R/W	CHG_TERMM	1	Charge termination event interrupt mask 0 : Interrupt is not masked 1 : Interrupt is masked
5	R/W	CHG_RECHGM	1	Re-Charge behavior interrupt mask 0 : Interrupt is not masked 1 : Interrupt is masked
4	R/W	SSFINISHM	1	Charger or boost-mode soft-start finishes event interrupt mask 0 : Interrupt is not masked 1 : Interrupt is masked
3	R/W	WDTMRM	1	Watch dog timer timeout fault interrupt mask 0 : Interrupt is not masked 1 : Interrupt is masked
2	R/W	CHGDET_DONEM	1	Charger-type detection done event interrupt mask 0 : Interrupt is not masked 1 : Interrupt is masked
1	R/W	CHG_ICHGMeasM	1	ICHG measurement function done event interrupt mask 0 : Interrupt is not masked 1 : Interrupt is masked
0	R/W	CHG_AICLMeasM	1	AICL measurement function done event interrupt mask 0 : Interrupt is not masked 1 : Interrupt is masked

Name		Function	Addr	Reset
CHG_IRQ3_CTRL		CHG IRQ 3 CTRL	0x65	0xFF
Bit	Mode	Name	Reset Value	Description
7	R/W	BST_OLPM	1	Boost overload protection event interrupt mask 0 : Interrupt is not masked 1 : Interrupt is masked
6	R/W	BST_MIDOVN	1	Boost PMID OVP fault event interrupt mask 0 : Interrupt is not masked 1 : Interrupt is masked
5	R/W	BST_BATUVM	1	Boost low-voltage input fault event interrupt mask 0 : Interrupt is not masked 1 : Interrupt is masked
[4:2]	R/W	Reserved	111	Reserved
1	R/W	PUMPX_DONEM	1	MTK pump express function done event interrupt mask 0 : Interrupt is not masked 1 : Interrupt is masked
0	R/W	ADC_DONEM	1	ADC measurement done event interrupt mask 0 : Interrupt is not masked 1 : Interrupt is masked

Name		Function	Addr	Reset
DPDM_IRQ_CTRL		DPDM IRQ CTRL	0x66	0xFF
Bit	Mode	Name	Reset Value	Description
7	R/W	DCDTM	1	Data contact detection event interrupt mask 0 : Interrupt is not masked 1 : Interrupt is masked
6	R/W	CHGDETM	1	Output of USB charger detection interrupt mask 0 : Interrupt is not masked 1 : Interrupt is masked
5	R/W	HVDCP DETM	1	HVDCP detection event interrupt mask 0 : Interrupt is not masked 1 : Interrupt is masked
[4:2]	R/W	Reserved	111	Reserved
1	R/W	Detach_M	1	VBUS detach event interrupt mask 0 : Interrupt is not masked 1 : Interrupt is masked
0	R/W	Attach_M	1	VBUS attach event interrupt mask 0 : Interrupt is not masked 1 : Interrupt is masked

Name		Function	Addr	Reset
CHG_IRQ5_CTRL		CHG IRQ 5 CTRL	0x68	0xFF
Bit	Mode	Name	Reset Value	Description
7	R/W	DIRCHG_OVM	1	Direct charge OV protection event interrupt mask 0 : Interrupt is not masked 1 : Interrupt is masked
6	R/W	DIRCHG_OCM	1	Direct charge OC protection event interrupt mask 0 : Interrupt is not masked 1 : Interrupt is masked
5	R/W	DIRCHG_UCM	1	Direct charge UC protection event interrupt mask 0 : Interrupt is not masked 1 : Interrupt is masked
4	R/W	DIRCHG_WDTMR M	1	Direct charge watch dog timer event interrupt mask 0 : Interrupt is not masked 1 : Interrupt is masked
3	R/W	DIRCHG_VGOKM	1	Direct charge path ready indicator event interrupt mask 0 : Interrupt is not masked 1 : Interrupt is masked
2	R/W	DIRCHG_VBUSO VM	1	Direct charge VBUS OV event interrupt mask 0 : Interrupt is not masked 1 : Interrupt is masked
[1:0]	R/W	Reserved	11	Reserved

Application Information

Direct Charge

Transition from Fast Charge to Direct Charge :

(1) `BYPASS_MODE = 1` (0x02, bit5), the switching charger is disabled, and the BATFET will be turned on to sustain the system loading to prevent shutdown.

(2) `VG_EN = 1` (0x18, bit0), the internal charge pump is enabled to turn on the external NMOSFET, enabling the direct charge path, which is through PMID to BAT.

Transition from Direct Charge to Fast Charge :

(1) `VG_EN = 0` (0x18, bit0), the internal charge pump is disabled, and the BATFET is kept turned on for continuous system operation.

(2) `BYPASS_MODE = 0` (0x02, bit5), the switching charger is enabled.

Protections for Direct Charge

(1) UC : Low charge current (around 600mA) protection in direct charge mode against input source having been removed.

(2) OVP of Battery : 0x1B (bit 6-4) is for Battery-OVP-related setting, including this function is enabled or not and user-programmable VBATOV range, from 104% to 119%.

(3) OVP of VBUS : 0x1D byte is for VBUS-OVP-related setting, including this function is enabled or not and user-programmable VBUSOV range, from 3.9V to 7V .

(4) OC : 0x1B (bit 3-0) is for direct-charge-current-related setting, including this function is enabled or not and user-programmable direct-charge over-current range, from 4A to 6.5A.

(5) Watch Dog Timer (WDT) : To prevent system from shutdown in direct charge status, the RT9468 also provide watch dog function which can set by 0x1C (bit 7 - 4).

(6) Protect deglitch time : The user-programmable deglitch time of the above protections can be set by 0x1C (bit 3 - 0)

Switching Charger

The switching charger integrates a synchronous PWM controller with power MOSFETs to provide Minimum Input Voltage Regulation (MIVR), Average Input Current Regulation (AICR), high-accuracy current and voltage regulation, and charge termination. The charger also features OTG (On-The-Go) Boost Mode.

The switching charger has three operation modes: charge mode, boost mode (OTG-Boost), and high-impedance mode. In charge mode, the charger supports a precision charging system for single cell batteries. In boost mode, the charger works as a boost converter to boost the battery voltage back to the VBUS pin for sourcing OTG devices. In high-impedance mode, the charger stops charging or boosting and operates at a low current sinking from the VBUS pin or the battery to reduce power consumption when the device is in standby mode.

Charge Mode Operation

Minimum Input Voltage Regulation (MIVR)

The switching charger features Minimum Input Voltage Regulation function to prevent input voltage drop due to insufficient current provided from the adapter or USB input. If MIVR function is enabled, the input voltage decreases when the over-current condition of the input power source occurs. The VBUS voltage is regulated at a predetermined voltage level which can be set as 3.9V to 13.4V per 0.1V by I2C interface. At this time, the current drawn by the switching charger equals to the maximum current value that the input power can provide at the predetermined voltage level, instead of the set value.

Pre-Charge Mode

For life-cycle consideration, the battery cannot be charged with large current under low-battery condition. When the BAT voltage is below pre-charge threshold voltage, the charger is in pre-charge mode with a weak charge current, which equals to the pre-charge current.

There are two control loops in pre-charge mode : ICHG and SYSREG. If the battery voltage is lower than the SYS voltage, the MOSFET will not be fully turned on so that

the V_{SYS} is not equal to V_{BAT} . That is, the V_{SYS} can be powered from the buck rather than the low battery, which is in pre-charge mode. As a result, the system power can be guaranteed in this low-battery condition.

Fast-Charge Mode and Settings

As the BAT voltage rises above V_{PRECHG} , the charger enters fast-charge mode and starts charging. Notice that the MUIC integrates input power source (AC adapter or USB input) detection. Thus, the switching charger can set the charge current via options automatically. Unlike the linear charger (LDO), the switching charger (buck converter) is like a current amplifier, where the current drawn by the switching charger is different from the current into the battery.

Average Input Current Regulation (AICR) level and output charge current (I_{CHG}) can be set independently.

Cycle-by-Cycle Current Limit

The switching charger has included a cycle-by-cycle current limit for output inductor. Once the inductor current reaches the current limit, the charger stops charging immediately to prevent from over-current condition and damaging the device. Note that this protection can never be disabled.

Average Input Current Regulation (AICR)

The AICR levels can be set via the I²C interface. For example, AICR100 mode limits the input current to 100mA, and AICR500 mode to 500mA. This function can be disabled, if not needed. The AICR current levels are in the range of 100mA to 3250mA with a resolution of 50mA.

Average Input Current Level (AICL)

The AICL levels can be set via the I²C interface (0x0E[7:0]). When IAICR is set to large current and the VBUS voltage drops to the VMIVR level, AICL measurement mechanism will decrease IAICR level step by step automatically until the VBUS voltage exceeds AICL threshold voltage.

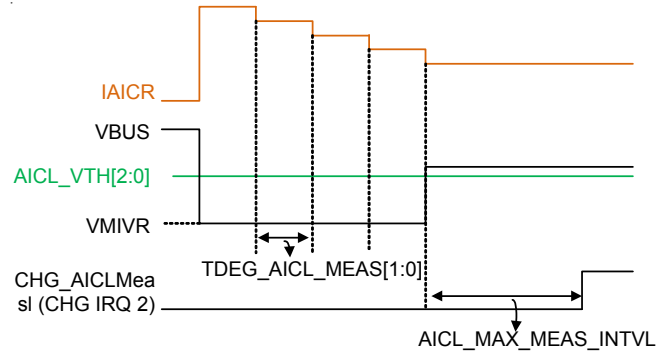

Charge Current (I_{CHG})

The charge current into a battery is determined by the power path sensing R_{on} and I_{CHG} setting by I²C. The voltage between the SYS and BAT pins is regulated to the voltage control by I_{CHG} setting and the fast-charge currents are 100mA to 5000mA in a step of 100mA, programmed by I²C

Constant Voltage Mode

The switching charger enters constant voltage mode when the BAT voltage is closed to the output-charge voltage (V_{OREG}). In this mode, the charge current begins to decrease. For default settings (charge current termination is disabled), the switching charger does not turn off and always regulates the battery voltage at V_{OREG} . However, once the charge current termination is enabled, the charger terminates if the charge current is below termination current (I_{EOC}) in constant-voltage mode. The output-charge voltage is set by the I²C interface. Its range is from 3.9V to 4.71V in a step of 10mV.

End-of-Charge Current (I_{EOC})

If the charger current termination is enabled, the end-of-charge current is determined by the termination current sense voltage (V_{EOC}). I_{EOC} is set by the I²C interface from 100mA to 850mA in a step of 50mA.

Charge Trip

When input power source is plugged in, the RT9468 checks the current sourcing capability of the input power source when V_{BUS} exceeds 3.3V. The following conditions should be met to start battery charge.

1. V_{BUS} is below 14V (i.e. V_{BUS_OVP}).

	Battery Voltage Level V_{BAT}	Battery Charge Current I_{BAT}
Trickle mode	$V_{BAT} < 2V$	100mA
Pre-charge mode	$V_{BAT} < V_{PREC}$ (0x08, bit[7:4])	I_{PREC} (0x08, bit[3:0])
Fast-charge mode	$V_{BAT} < V_{OREG}$ (0x04, bit[7:1])	Charge current is determined by several control loops
End-of-charge mode	$V_{BAT} = V_{OREG}$ (0x04, bit[7:1])	Charge current decreases naturally

2. V_{BUS} is above 3.8V (i.e. V_{BAD_ADP}) when sinking 50mA (i.e. $I_{BAD_ADP_SINK}$) during 30ms of detection period, t_{BADADP_DET} . And this detection function can be disabled by ADP_DIS (0x0B, bit7) register bit.

The charge modes as below, and the charge mode which the charger operates in will be determined according to the V_{BAT} level :

In fast-charge mode, the input current limit can be selected by $IINLMTSEL$ (0x02, bit[3:2]). This flexible setting is suitable for wide applications of adapters. In addition, the RT9468 also provides charger warning statuses, such as $MIVR$, $AICR$ and $TREG$ (0x50, bit[6:4]), to host.

There are 2 register bits, related to the LX switching of the RT9468 :

- SEL_SWFREQ** (0x01, bit7) :
 - ▶ If SEL_SWFREQ is disabled (set to 0), the switching frequency is 1.5MHz (default).
 - ▶ If SEL_SWFREQ is enabled (set to 1), the switching frequency is 0.75MHz.
- FIXFREQ** (0x01, bit6) :
 - ▶ If $FIXFREQ$ is disable (set to 0), the charge switching frequency would be varied when V_{BUS} is closed to V_{BAT} .
 - ▶ If $FIXFREQ$ is enable (set to 1), the charger switching frequency is fixed.

There are 3 enable bits, related to the charger.

- CFO_EN** (0x02, bit1) : This bit is used to enable or disable the charger and boost.
- CHG_EN** (0x02, bit0) : When CHG_EN bit is disabled, power path MOS will be turned off so that the zero charging current is derived. At this time, input power source continuously delivers power to the system without charging the battery. However, if the system load is larger than the input source current limit, the power path MOS will be turned back on immediately to

supply power to system. The CHG_EN bit function is same as CEB pin.

- HZ** (0x01, bit2) : When HZ bit is enabled, the most of the charger internal circuits will be turned off in order to reduce quiescent current.

In end-of-charge mode, if EOC_EN (0x09, bit3) is enabled, once the charge current is lower than I_{EOC} (0x09, bit[7:4]) level and within CHG_TEDG_EOC (0x09, bit[2:0]), the RT9468 will send out INT and $CHG_IEOC1 = 1$ (0x54, bit7). Then, the RT9468 will start to check statuses of the following three bits.

- TE** (0x02, bit4) : If this bit is enabled, the power path will be turned off, and the buck of the charger will keep providing power to the system.
- EOC_TIMER** (0x07, bit[1:0]) : With $CHG_IEOC1 = 1$, the power path will not be turned off. The RT9468 can keep charging the battery for 30 to 60 minutes to extend battery charging capacity.
- BATD_EN** (0x0B, bit6) : After charge is done, the RT9468 will start to sink a sink current of I_{BAT_SINK} 375 μ A for about 256ms from the battery. If V_{BAT} drops to trigger the recharge function, it is to say the battery is not connected to the charger. The RT9468 will continue on battery detection for every two seconds.

OTG Mode

The RT9468 also supports OTG mode. It not only provides several output current limit protection levels, but also has low battery protection for overall system considerations. The RT9468 can select switching frequency via SEL_SWFREQ (0x01, bit7), whether the RT9468 already operates in OTG mode or not.

There are two ways to enable OTG mode :

- By way of software : through I²C to set OPA_MODE (0x01, bit0).

2. By way of hardware : through I²C to set OTG_PIN_EN (0x01, bit1) and OPA_MODE (0x01, bit0). Users can then use GPIO to change the OTG pin level to enter / exit OTG mode.

The RT9468 also provides UUG_ON (0x0D, bit1) bit, which can be applied to different applications

1. If OTG mode and UUG_ON are enabled, the boost-mode output is on the VBUS pin, which can be used for OTG (On-the-Go) mode in mobile phones.
2. If OTG mode is enabled and UUG_ON bit is disabled, the boost-mode output is on the PMID pin. , which can be used in power banks, that is, adapter power can be delivered to PD (Powered Device) directly.

Shipping Mode

From manufacture to an end user, it may take long time for products to travel. In view of this, the RT9468 provides shipping mode to further minimize battery leakage. After enabling SHIP_MODE (0x02, bit7), the RT9468 will shut down internal circuits to reduce quiescent current. The delay time for BATFET to be turned off can be selected by BATDET_DIS_DLY (0x02, bit6). Below list several ways to exit shipping mode.

1. Input power source is plugged in.
2. Disable SHIP_MODE bit.
3. QON pin is pulled from Logic High to Logic Low within 1 second.
4. Enable RST_REG (0x00, bit7) to reset all registers to default values.

MeidaTek Pump Express+ (MTK, PE+)

The RT9468 can provides an input current pulse to communicate with an MTK-PE+ high voltage adapter. When EN_PUMPX (0x19, bit7) is enabled, the host can increase or decrease adapter output voltage by setting PUMPX_UP_DN to the desired value. After enabling either one of them, the RT9468 will generate a VBUS current pattern for the MTK-PE+ adapter to automatically identify whether to increase or decrease output voltage (VBUS pin). Once the current pattern is finished, INT will be triggered accordingly to request the processor to read the registers.

JEITA Protection

JEITA protection is implemented in the RT9468 to achieve battery thermal protection. JEITA guidelines were released in 2007. It includes warm and cool protection (Cool section is between T1 and T2; warm section is between T3 and T4, see the figure below). When battery temperature is in warm section, the RT9468 will lower the charge voltage (V_{OREG}) by 200mV. If the battery is in cool section, the charger will reduce charge current (by half of CC mode current). The RT9468 will stop charging the battery if the battery temperature is lower than T1 or higher than T4.

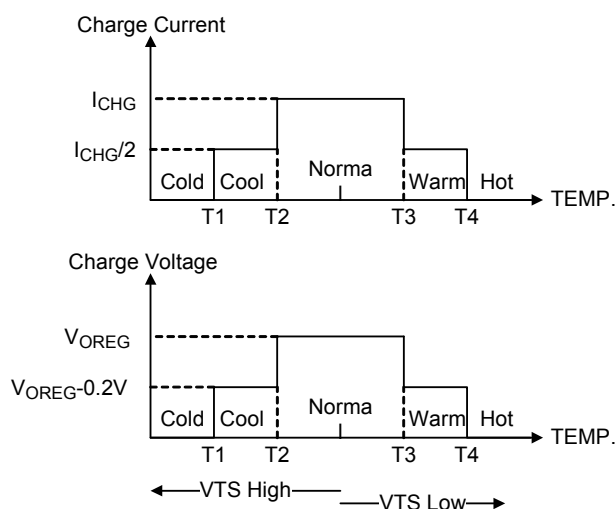

Thermal condition of a battery can be monitored by TS pin. There are four sections which are implemented for JEITA protection. Based on R_{HOT} and R_{COLD}, R_{T1} and R_{T2} can be calculated with equation (1) and equation (2). Herein, R_{HOT} is the NTC resistance of the battery over-temperature threshold, and R_{COLD} is the NTC resistance of the battery under-temperature threshold.

$$R_{T1} = V_{REGN} \times [(1/V_{T1} - 1/V_{T4}) / (1/R_{Cold} - 1/R_{Hot})] \quad (1)$$

$$R_{T2} = R_{T1} \times [1 / (V_{REGN} / V_{T1} - R_{T1} / R_{Cold} - 1)] \quad (2)$$

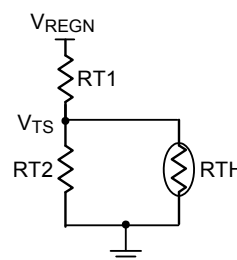

The respective percentages of the voltages at T1~T4 are shown in the following table.

No.	Parameter	Symbol	Condition	$\frac{V_{TS}}{V_{REGN}}$	Units
1	T1 (0°C) Threshold	V_{T1}	V_{TS} rising, as percentage to V_{REGN}	73.5	%
2	T1 Hysteresis	V_{T1_HYS}	Hysteresis, V_{TS} falling	2	%
3	T2 (10°C) Threshold	V_{T2}	V_{TS} rising, as percentage to V_{REGN}	68.5	%
4	T2 Hysteresis	V_{T2_HYS}	Hysteresis, V_{TS} falling	2	%
5	T3 (45°C) Threshold	V_{T3}	V_{TS} falling, as percentage to V_{REGN}	45	%
6	T3 Hysteresis	V_{T3_HYS}	Hysteresis, V_{TS} rising	2	%
7	T4 (60°C) Threshold	V_{T4}	V_{TS} falling, as percentage to V_{REGN}	34.5	%
8	T4 Hysteresis	V_{T4_HYS}	Hysteresis, V_{TS} rising	2	%

Analog IR Drop Compensation

Since resistance between charger output and battery cell terminal will force to move from constant current mode to constant voltage mode too early and increase charging time. To speed up charging cycle, RT9468 provides analog IR drop compensation function to delivery maximum power to battery for extend constant current mode charging time. Host(AP) can set IR compensation function by BAT_COM (0x1A bit[5:3]) and VCLAMP (0x1A bit[2:0]).

$$V_{ACTUAL} = V + \min (I_{CHG_ACTURAL} \times BAT_COM, V_{CLAMP})$$

CHG STAT

There is one way to check RT9468's status :

The RT9468 status is indicated in the register of address 0x42 as below.

- ▶ CHG_STAT : Charger status
- ▶ BOOST_STAT : Boost mode status
- ▶ ADC_STAT : ADC status. Check whether ADC is active or idle

Interrupt

The RT9468 reports status to host (CPU, MCU, EC, or...etc.) by the INT (interrupt to host) pin, which is an open-drain output. The INT pin goes low when any fault occurs. It will be automatically reset when all the fault flags are cleared. The IRQ_PULSE (0x01, bit3) provides a reminder function. If the system interrupts by the interrupt signal but does not take any action to check the registers, the INT pin will be released with every 2 seconds and be triggered again.

The RT9468 INT pin is used to indicate whether the any charging events occur. When AP (Access Point) detects a falling edge on the INT pin, AP starts to read the INT register 0x51 to 0x58 sequentially. However, if any of the events is triggered again during this checking period, it will be a miss. If any of the INT registers does not be checked, the INT_REZ bit can help release the INT pin with 2ms then reset it again in order to remind hot the missing events again.

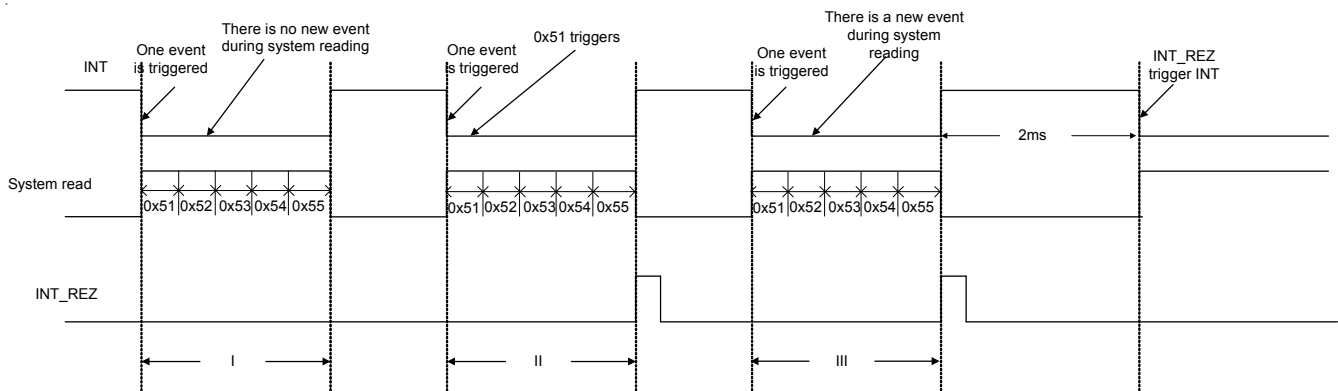

ILIM Pin

For hardware protection, the RT9468 supports input current limit setting on the ILIM pin by way of a resistor from ILIM pin to ground.

$$I_{INMAX} = K_{ILIM} / R_{ILIM}$$

For example, if the input current limit is to be set as 2A with a typical input current limit factor K_{ILIM} as 355AΩ, a resistor of 180Ω will then be chosen as the resistor from the ILIM pin to ground. The actual input current limit is the minimum between the result of IINLMTSEL (0x02, bit[3:2]) and ILIM.

ADC Conversion Operation Flow

The figure below shows the flow chart of ADC conversion operation. ADC conversion starts from selecting an ADC channel by setting ADC_IN_SEL (0x11, bit[7:4]) and enabling ADC_START (0x11, bit0). After about 200ms of ADC conversion time for a conversion to be completed, ADC_DONE1 (0x55, bit0) will be enabled and ADC_STAT (0x42, bit 0) will be disabled. The host can be informed that ADC conversion is completed by reading the register bits.

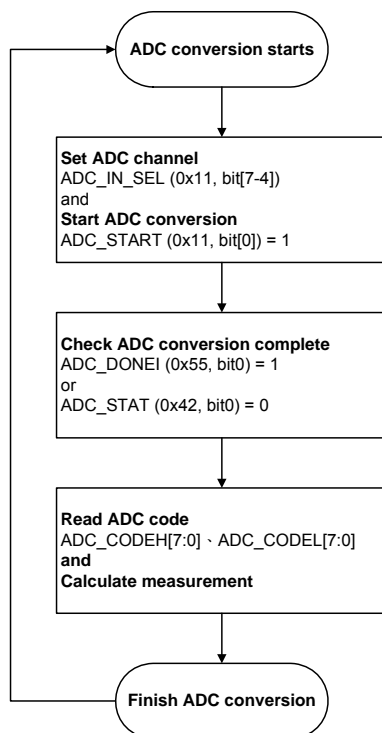

The host can read ADC high-byte codes from ADC_CODEH (0x44, bit 7-0) and low-byte codes from ADC_CODEL (0x45, bit 7-0) to calculate the measured voltage /current /temperature data with respect to each ADC channel. The table below shows measurement equations for various ADC channels. When measuring IBUS, the AICR setting need large 350mA at least. When measuring IBAT, the ICHG setting need large 1A at least.

ADC Channel	Measurement Equation	Measurement Range
VBUS_DIV5	$[(ADC_CODEH \times 256) + ADC_CODEL] \times 25mV$	1V to 22V
VBUS_DIV2	$[(ADC_CODEH \times 256) + ADC_CODEL] \times 10mV$	1V to 9.8V
VBAT/VBATS	$[(ADC_CODEH \times 256) + ADC_CODEL] \times 5mV$	0V to 4.9V
VSYS	$[(ADC_CODEH \times 256) + ADC_CODEL] \times 5mV$	0V to 4.9V
REGN	$[(ADC_CODEH \times 256) + ADC_CODEL] \times 5mV$	0V to 4.9V
TS_BAT/TS_BUS	$[(ADC_CODEH \times 256) + ADC_CODEL] \times 0.25\%$	0% to 100%
IBUS IAICR[5:0] setting < 400mA	$[(ADC_CODEH \times 256) + ADC_CODEL] \times 50mA \times 0.67$	0A to 0.4A
IBUS IAICR[5:0] setting ≥ 400mA	$[(ADC_CODEH \times 256) + ADC_CODEL] \times 50mA$	0A to 5A
IBAT / IBATS ICHG[5:0] setting 100mA to 450mA	$[(ADC_CODEH \times 256) + ADC_CODEL] \times 50mA \times 0.57$	0A to 0.45A
IBAT / IBATS ICHG[5:0] setting 500mA to 850mA	$[(ADC_CODEH \times 256) + ADC_CODEL] \times 50mA \times 0.63$	0A to 0.85A
IBAT / IBATS ICHG[5:0] setting ≥ 900mA	$[(ADC_CODEH \times 256) + ADC_CODEL] \times 50mA$	0A to 5A
TEMP_JC	$[(ADC_CODEH \times 256) + ADC_CODEL] \times 2^{\circ}C - 40^{\circ}C$	-40 to 120°C

I²C Interface Timing Diagram

The RT9468 acts as an I²C -bus slave. The I²C -bus master configures the settings for charge mode and boost mode by sending command bytes to the RT9468 via the 2-wire I²C -bus. After the START condition, the I²C master sends

a chip address. This address is seven bits long followed by an eighth bit which is a data direction bit (R/W). The second byte selects the register to which the data will be written. The third byte contains data to the selected register.

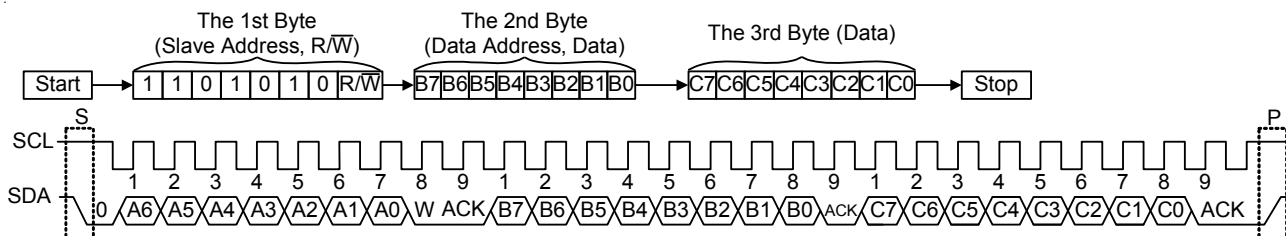

Thermal Considerations

The junction temperature should never exceed the absolute maximum junction temperature $T_{J(MAX)}$, listed under Absolute Maximum Ratings, to avoid permanent damage to the device. The maximum allowable power dissipation depends on the thermal resistance of the IC package, the PCB layout, the rate of surrounding airflow, and the difference between the junction and ambient temperatures. The maximum power dissipation can be calculated using the following formula :

$$P_{D(MAX)} = (T_{J(MAX)} - T_A) / \theta_{JA}$$

where $T_{J(MAX)}$ is the maximum junction temperature, T_A is the ambient temperature, and θ_{JA} is the junction-to-ambient thermal resistance.

For continuous operation, the maximum operating junction temperature indicated under Recommended Operating Conditions is 125°C. The junction-to-ambient thermal resistance, θ_{JA} , is highly package dependent. For a WQFN-32L 4x4 package, the thermal resistance, θ_{JA} , is 27.8°C/W on a standard JEDEC 51-7 high effective-thermal-conductivity four-layer test board. The maximum power dissipation at $T_A = 25^\circ\text{C}$ can be calculated as below :

$$P_{D(MAX)} = (125^\circ\text{C} - 25^\circ\text{C}) / (27.8^\circ\text{C/W}) = 3.59\text{W for a WQFN-32L 4x4 package.}$$

The maximum power dissipation depends on the operating ambient temperature for the fixed $T_{J(MAX)}$ and the thermal resistance, θ_{JA} . The derating curves in Figure 1 allows the designer to see the effect of rising ambient temperature on the maximum power dissipation.

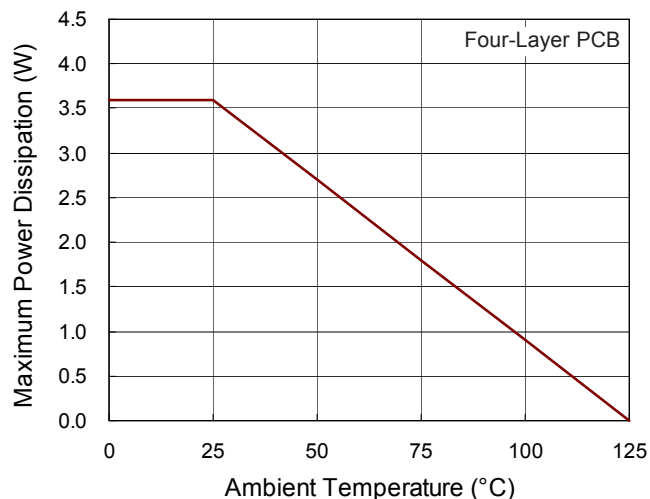

Figure 1. Derating Curve of Maximum Power Dissipation

Layout Consideration

The RT9468 layout guideline is shown as follow. There are several suggestion are provided.

- ▶ AGND should be connected to PGND at GND plane.
- ▶ The capacitor of PMID should be as close as possible to RT9468 for reduce EMI.
- ▶ The GND path of PMID and VBUS capacitor needs to connect directly at TOP layer.
- ▶ PGND connects to thermal heat sink can improve thermal performance.

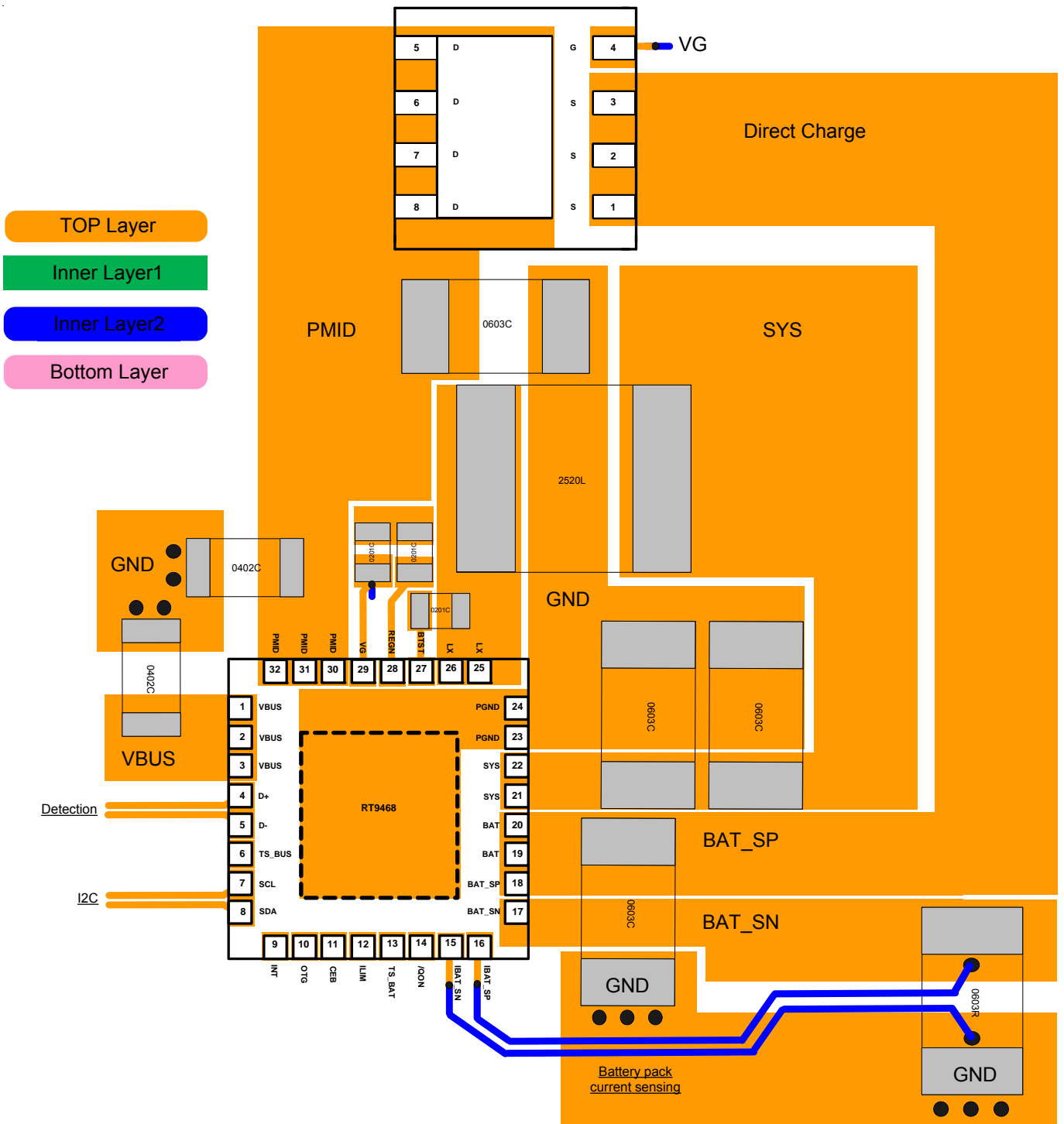
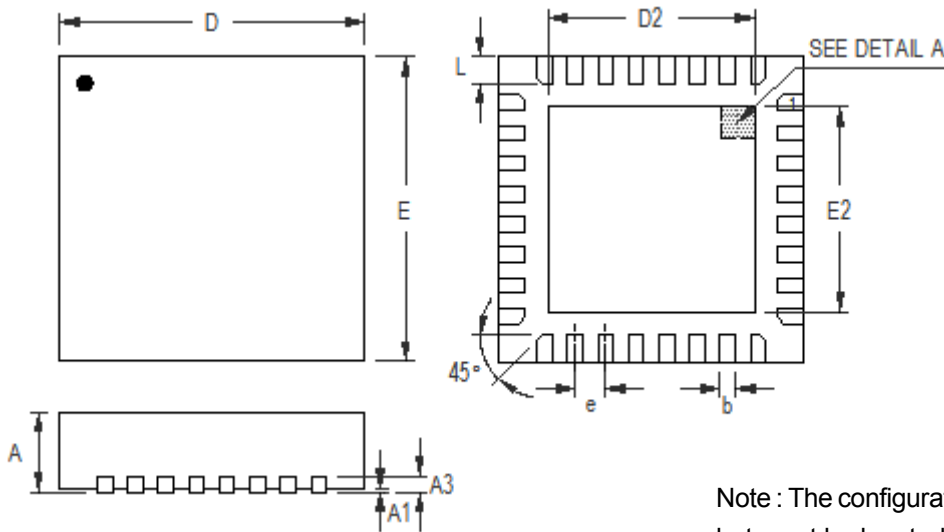

Figure 2. PCB Layout Guide

Outline Dimension



DETAIL A

Pin #1 ID and Tie Bar Mark Options

Note : The configuration of the Pin #1 identifier is optional, but must be located within the zone indicated.

Symbol	Dimensions In Millimeters		Dimensions In Inches	
	Min	Max	Min	Max
A	0.700	0.800	0.028	0.031
A1	0.000	0.050	0.000	0.002
A3	0.175	0.250	0.007	0.010
b	0.150	0.250	0.006	0.010
D	3.900	4.100	0.154	0.161
D2	2.650	2.750	0.104	0.108
E	3.900	4.100	0.154	0.161
E2	2.650	2.750	0.104	0.108
e	0.400		0.016	
L	0.300	0.400	0.012	0.016

W-Type 32L QFN 4x4 Package

Footprint Information

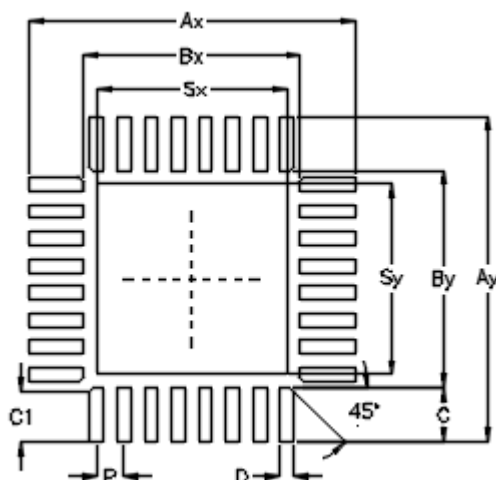

Package	Number of Pin	Footprint Dimension (mm)										Tolerance
		P	Ax	Ay	Bx	By	C*32	C1*8	D	Sx	Sy	
V/W/U/XQFN4*4-32	32	0.40	4.80	4.80	3.20	3.20	0.80	0.75	0.20	2.80	2.80	±0.05

Richtek Technology Corporation

14F, No. 8, Tai Yuen 1st Street, Chupei City

Hsinchu, Taiwan, R.O.C.

Tel: (8863)5526789

Richtek products are sold by description only. Richtek reserves the right to change the circuitry and/or specifications without notice at any time. Customers should obtain the latest relevant information and data sheets before placing orders and should verify that such information is current and complete. Richtek cannot assume responsibility for use of any circuitry other than circuitry entirely embodied in a Richtek product. Information furnished by Richtek is believed to be accurate and reliable. However, no responsibility is assumed by Richtek or its subsidiaries for its use; nor for any infringements of patents or other rights of third parties which may result from its use. No license is granted by implication or otherwise under any patent or patent rights of Richtek or its subsidiaries.