

## High Efficiency Single Inductor Buck-Boost Converter

### General Description

The RTQ1741A is a high efficiency single inductor Buck-Boost Converter which can operate with wide input voltage such as battery which is higher or lower than the output voltage and it can supply the load current up to 4A. The maximum peak current in the switches is limited to a typical value of 4.5A.

The RTQ1741A feedback loop is internally compensated for both Buck and Boost operation and it provides seamless transition between Buck and Boost modes and optimal transient response. The RTQ1741A operates at 2.4MHz typical switching frequency in full synchronous operation.

The RTQ1741A operates in Pulse Skipped Modulation (PSM) mode for increasing efficiency during low power RF transmission modes. The Power Save Mode can be disabled, forcing the RTQ1741A to operate at a fixed switching frequency operation at 2.4MHz. The RTQ1741A can also be synchronized with external frequency from 2.2MHz to 2.6MHz. The output voltage is programmable using an external resistor divider.

### Applications

- Cellular Phones
- Portable Hard Disk Drives
- PDAs

### Features

- Operates from a Single Li-ion Cell : 1.8V to 5.5V
- Adjustable Output Voltage : 1.8V to 5.5V
- 3A Maximum Load Capability for  $V_{IN} > 3.6V$ ,  $V_{OUT} = 3.3V$
- Power Save Mode (PSM) for Improving Low Output Power Efficiency
- Fixed Frequency Operation at 2.4MHz and Synchronization Possible from 2.2MHz to 2.6MHz
- Up to 96% Efficiency
- Input Current Limit
- Internal Compensation
- RoHS Compliant and Halogen Free

### Pin Configuration

(TOP VIEW)

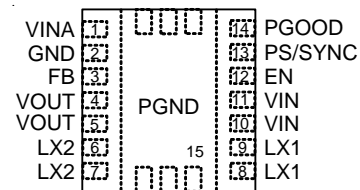

WDFN-14AL 4x3

### Simplified Application Circuit

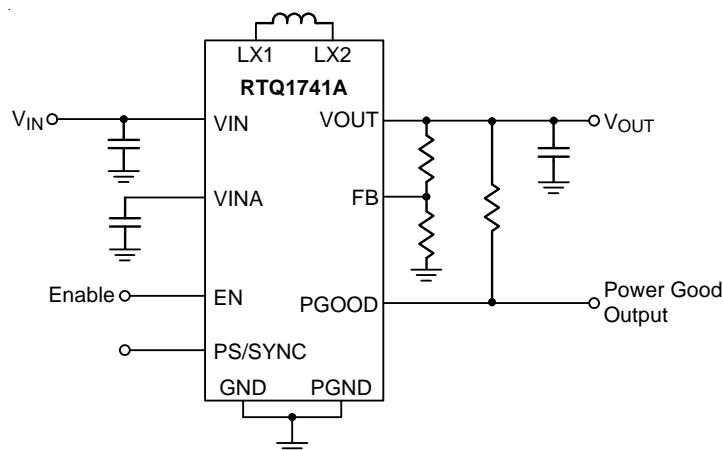

## Ordering Information

RTQ1741A □ □

- Package Type  
QW : WDFN-14AL 4x3 (W-Type)
- Lead Plating System  
G : Green (Halogen Free and Pb Free)

## Marking Information

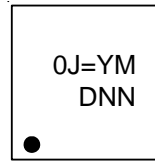

0J= : Product Code  
YMDNN : Date Code

Note :

Richtek products are :

- ▶ RoHS compliant and compatible with the current requirements of IPC/JEDEC J-STD-020.
- ▶ Suitable for use in SnPb or Pb-free soldering processes.

## Functional Pin Description

Pin No.	Pin Name	Pin Function
1	VINA	Supply voltage input.
2	GND	Analog ground.
3	FB	Voltage feedback of adjustable versions, must be connected to VOUT on fixed output voltage versions.
4, 5	VOUT	Buck-boost converter output.
6, 7	LX2	Second switch node.
8, 9	LX1	First switch node.
10, 11	VIN	Power input.
12	EN	Enable control input (1 Enabled, 0 Disabled). Must not be left open.
13	PS/SYNC	Enable/disable control input for power save mode (1 disabled, 0 enabled, clock signal for synchronization). Must not be left open.
14	PGOOD	Power good indicator Output. (1 good, 0 failure; open drain).
15 (Exposed Pad)	PGND	Power ground. The exposed pad must be soldered to a large PCB and connected to PGND for maximum power dissipation.

**Functional Block Diagram**

RTQ1741A (Adjustable Output Voltage)

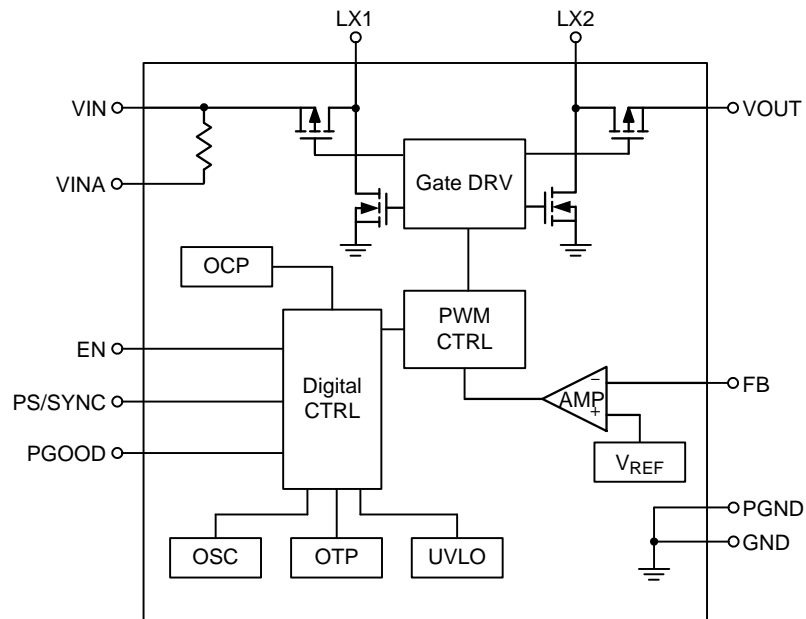

## Operation

The RTQ1741A is a synchronous current-mode switching Buck-Boost converter designed to an adjustable output voltage from an input supply that can be above, equal, or below the output voltage. The average inductor current is regulated by a fast current regulator which is controlled by a voltage control loop. The voltage error amplifier gets its feedback input from the FB pin. The output voltage of the RTQ1741A is adjustable, and can be set by the external divider resistor value. When  $V_{IN}$  is greater than  $V_{OUT}$ , the device operates in Buck mode. When  $V_{IN}$  is lower than  $V_{OUT}$ , the device operates in Boost mode. When  $V_{IN}$  is close to  $V_{OUT}$ , the RTQ1741A automatically enters Buck or Boost mode. In that case, the converter will maintain the regulation for output voltage and keep a minimum current ripple in the inductor to guarantee good performance.

**Absolute Maximum Ratings** (Note 1)

- VIN, VINA to GND ----- -0.2V to 6V
- VOUT to GND ----- -0.2V to 6.5V
- EN, PS/SYNC to GND ----- -0.2V to (PVIN + 0.2V) with 6V max.
- FB to PGND ----- -0.2V to (PVIN + 0.2V) with 6V max.
- LX1 ----- (PGND – 0.2V) to (PVIN + 0.2V) with 6V max.
- LX2 ----- (PGND – 0.2V) to (PVIN + 0.2V) with 6.5V max.
- Power Dissipation, P<sub>D</sub> @ T<sub>A</sub> = 25°C
  - WDFN-14AL 4x3 ----- 3.49W
- Package Thermal Resistance (Note 2)
  - WDFN-14AL 4x3, θ<sub>JA</sub> ----- 28.6°C/W
  - WDFN-14AL 4x3, θ<sub>JC</sub> ----- 3.2°C/W
- Lead Temperature (Soldering, 10 sec.) ----- 260°C
- Junction Temperature ----- 150°C
- Storage Temperature Range ----- -65°C to 150°C
- ESD Susceptibility (Note 3)
  - HBM (Human Body Model) ----- 2kV

**Recommended Operating Conditions** (Note 4)

- Input Voltage Range ----- 1.8V to 5.5V
- Output Voltage Range ----- 1.8V to 5.5V
- Junction Temperature Range ----- -40°C to 125°C
- Ambient Temperature Range ----- -40°C to 85°C

**Electrical Characteristics**

(V<sub>IN</sub> = 3.6V, T<sub>A</sub> = -40°C to 85°C, unless otherwise specified.)

Parameter	Symbol	Test Conditions	Min	Typ	Max	Unit
Under-Voltage Lockout Rising Threshold	UVLO_R		1.55	1.7	1.85	V
Under-Voltage Lockout Falling Threshold	UVLO_F		1.45	1.6	1.75	V
Minimum Input Voltage for Start-Up			1.5	1.8	2.0	V
FB Voltage	V <sub>FB</sub>	Forced PWM	0.49	0.5	0.51	V
VOUT Voltage	V <sub>OUT</sub>		3.233	3.3	3.366	V
Shutdown Current	I <sub>SHDN</sub>	EN = 0V, PS/SYNC = 0V, PGOOD = 0V	--	0.1	3	μA
Switching Frequency	f <sub>sw</sub>		2	2.4	2.8	MHz
Frequency Range for Synchronization			2.2	2.4	2.6	MHz
Current Limit	I <sub>OC</sub>	V <sub>IN</sub> = V <sub>INA</sub> = 3.6V	3.5	4.5	6.5	A

Parameter	Symbol	Test Conditions	Min	Typ	Max	Unit
High-Side Switch $R_{DS(ON)}$		$V_{IN} = V_{INA} = 3.6V$	--	50	100	$m\Omega$
Low-Side Switch $R_{DS(ON)}$		$V_{IN} = V_{INA} = 3.6V$	--	50	100	$m\Omega$
Quiescent Current		Non switching, $EN = V_{INA}$ , $SYNC = 0V$ ( $T_A = -20^\circ C$ to $85^\circ C$ )	--	20	80	$\mu A$
FB Input Leakage	$I_{FB}$	ADJ mode	-1	--	1	$\mu A$
Leakage of LX1 and LX2	$I_{LX1}$ $I_{LX2}$	All switch off	--	--	5	$\mu A$
Line Regulation	$\Delta V_{OUT, LINE}$	FPWM	--	0.5	--	%
Load Regulation	$\Delta V_{OUT, LOAD}$	FPWM	--	0.5	--	%
EN, PS/SYNC Input Voltage	Logic-High	$V_{IH}$	1.2	--	--	V
	Logic-Low	$V_{IL}$	--	--	0.4	
PS/SYNC Input Current			--	0.1	1	$\mu A$
EN Pull Low Resistance			120	150	180	$k\Omega$
PGOOD Output Low Voltage		$V_{OUT} = 3.3V$ , $I_{PGOODL} = 10\mu A$	--	0.04	0.4	V
PGOOD Output Leakage Current			--	0.01	0.1	$\mu A$
Output Over-Voltage Protection	$V_{OUTOVP}$		--	6.2	6.4	V
Thermal Shutdown	$T_{SD}$		--	160	--	$^\circ C$
Thermal Shutdown Hysteresis	$\Delta T_{SD}$		--	30	--	$^\circ C$

- Note 1.** Stresses beyond those listed under “Absolute Maximum Ratings” may cause permanent damage to the device. These are stress ratings only, and functional operation of the device at these or any other conditions beyond those indicated in the operational sections of the specifications is not implied. Exposure to absolute maximum rating conditions may affect device reliability.
- Note 2.**  $\theta_{JA}$  is measured under natural convection (still air) at  $T_A = 25^\circ C$  with the component mounted on a high effective-thermal-conductivity four-layer test board on a JEDEC 51-7 thermal measurement standard.  $\theta_{JC}$  is measured at the exposed pad of the package.
- Note 3.** Devices are ESD sensitive. Handling precaution is recommended.
- Note 4.** The device is not guaranteed to function outside its operating conditions.

**Typical Application Circuit**

RTQ1741A (Adjustable Output Voltage)

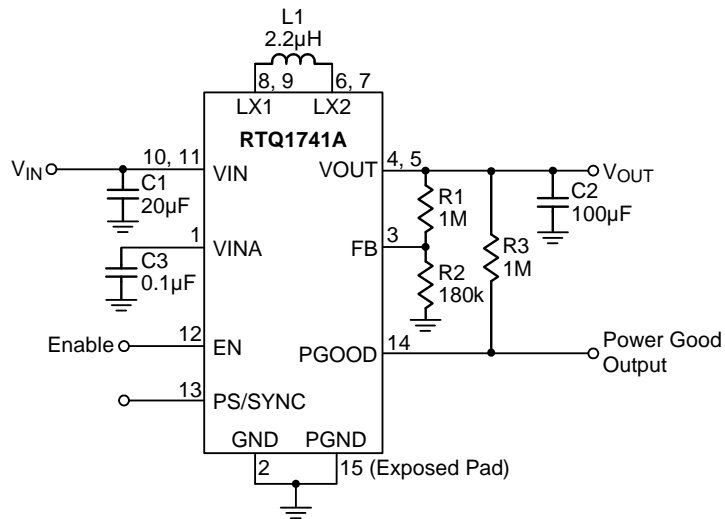

Typical Operating Characteristics

Efficiency vs. Output Current

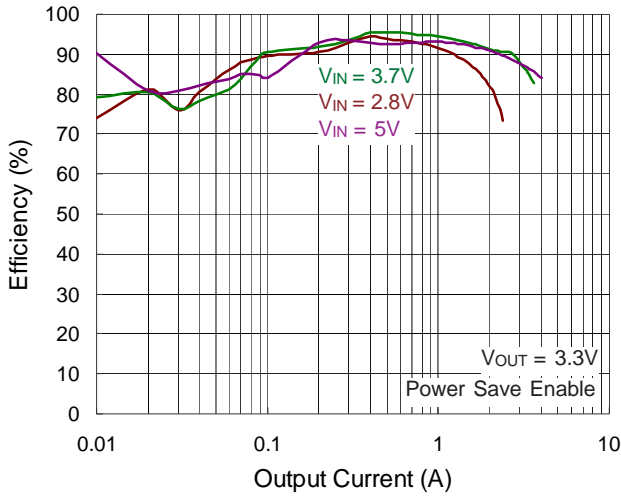

Efficiency vs. Output Current

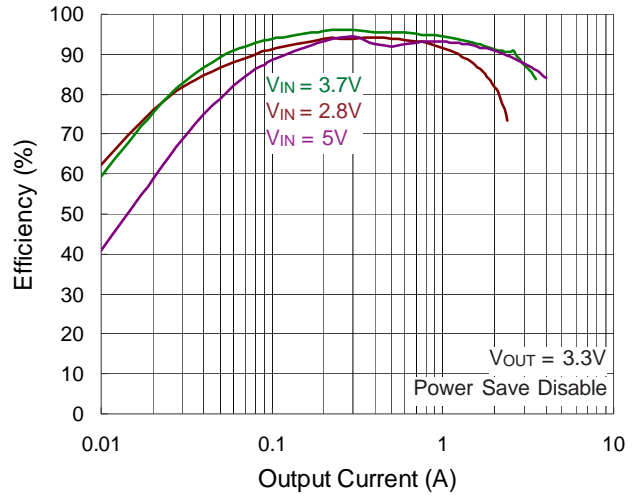

Efficiency vs. Output Current

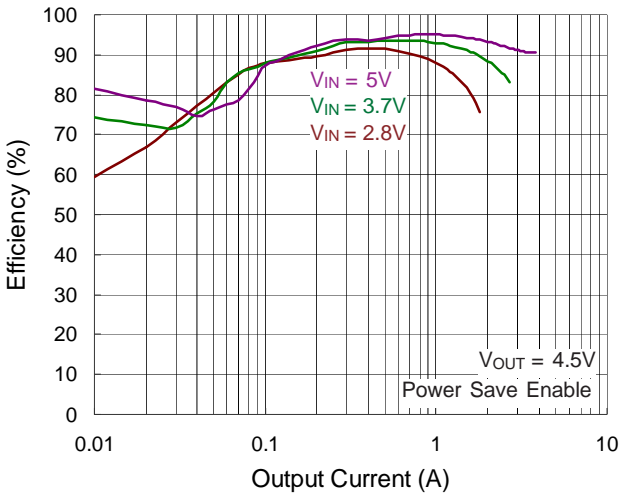

Efficiency vs. Output Current

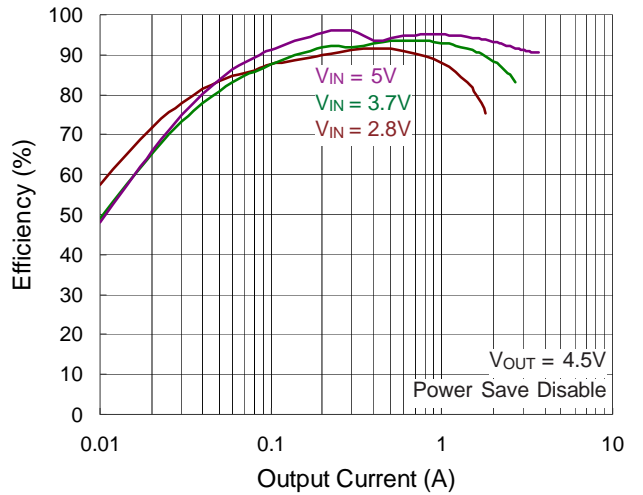

Output Voltage vs. Output Current

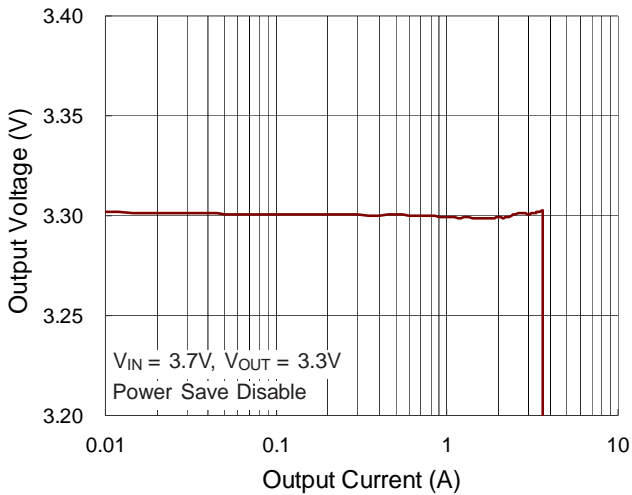

Output Voltage vs. Output Current

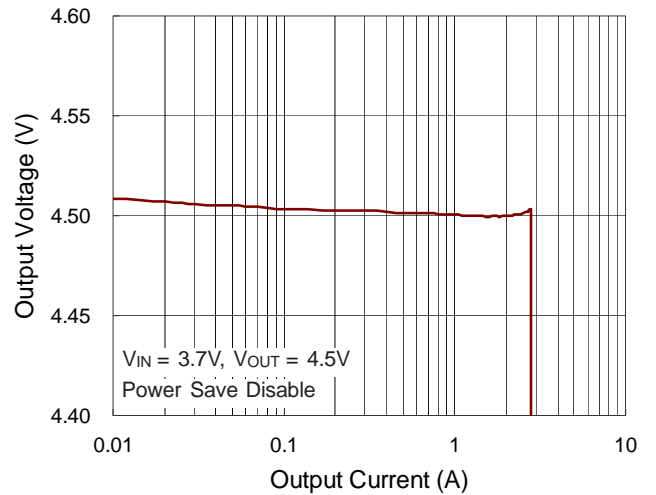



**Maximum Output Current vs. Input Voltage**

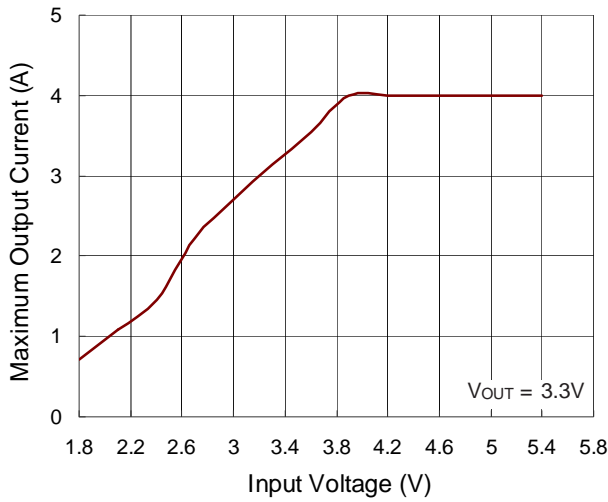

**Load Transient Response**

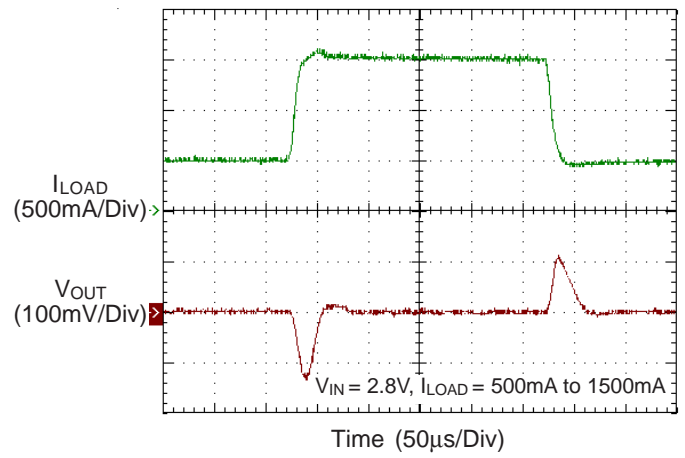

**Load Transient Response**

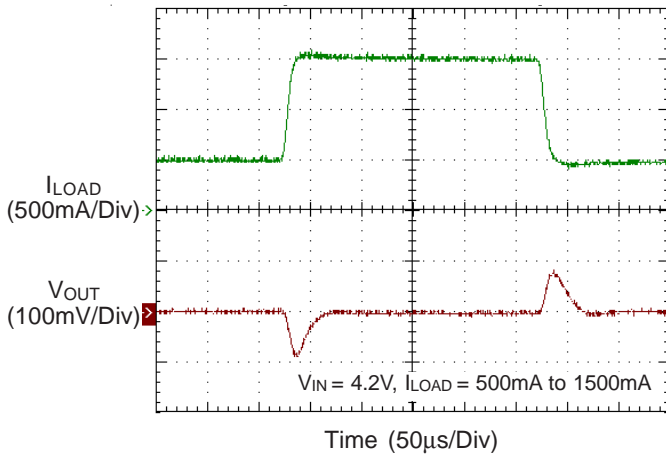

**Line Transient Response**

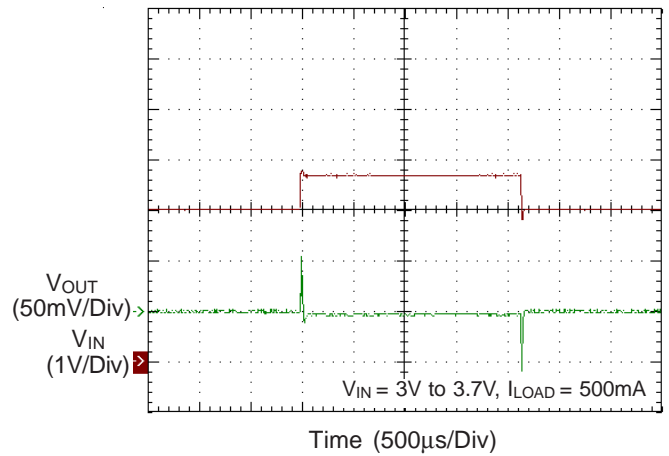

**Line Transient Response**

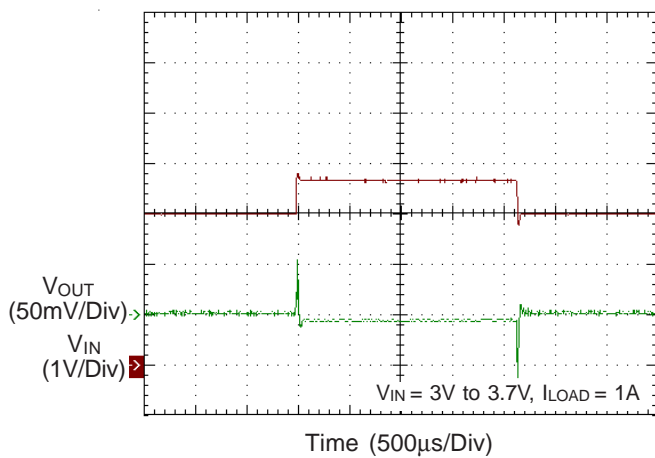

**Startup After Enable**

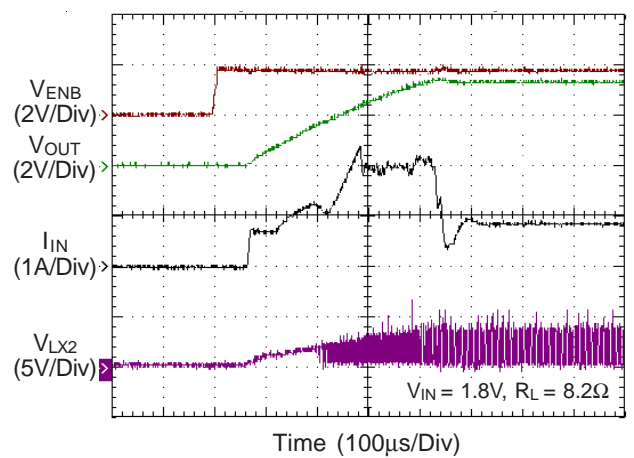

### Startup After Enable

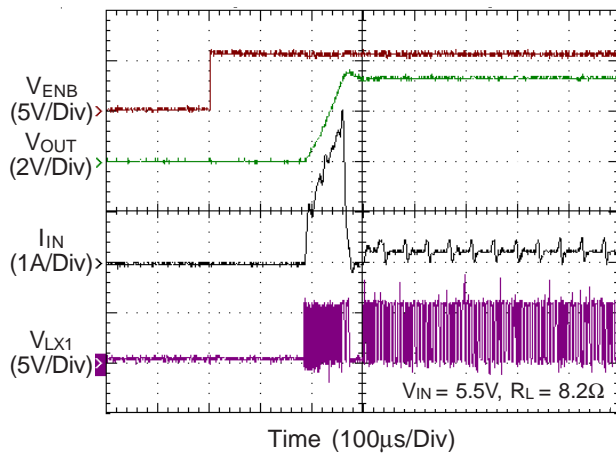

## Application Information

The RTQ1741A Buck-Boost DC-DC converter can operate with wide input voltage such as battery which is higher or lower than the output voltage and it can supply the load current up to 4A. The maximum peak current in the switches is limited to a typical value of 4.5A. The typical operating input voltage is between 1.8V and 5.5V. The RTQ1741A output voltage can be set from 1.8V to 5.5V by changing the external divider resistor on the FB pin for the adjustable. The converter feedback loop is internally compensated for both Buck and Boost operation and it provides seamless transition between Buck and Boost modes operation.

### Enable

The device can be enabled or disabled by the EN pin. When the EN pin is higher than the threshold of logic high, the device starts operation with soft-start. Once the EN pin is set at low, the device will be shut down. In shutdown mode, the converter stops switching, internal control circuitry is turned off, and the load is disconnected from the input. This also means that the output voltage can drop below the input voltage during shutdown.

### Output Voltage Setting

The RTQ1741A output voltage can be set from 1.8V to 5.5V by changing the external divider resistor on the FB pin. When the adjustable output voltage version is used, the resistor divider must be connected between VOUT, FB and GND. The typical value of the voltage at the FB pin is 500mV and the RTQ1741A output voltage can be set from 1.8V to 5.5V. It is recommended to keep the resistor R2 value in the range of 200kΩ. From that, the value of the resistor connected between VOUT and FB, R1, depending on the needed output voltage, can be calculated as following equation :

$$R1 = R2 \times \left( \frac{V_{OUT}}{V_{FB}} - 1 \right)$$

### Power Good

The RTQ1741A has a built-in power good function on PGOOD pin to indicate whether the output voltage is regulated properly or not. The PGOOD pin output is open-drain, so the logic function can be adjusted to any voltage level by connecting a pull-up resistor to the supply voltage. When the output voltage is regulated properly, the PGOOD pin becomes high impedance and indicates high level to the power good output. When the output voltage is regulated improperly, the PGOOD pin becomes low impedance and indicates low level to the power good output.

### Power-Save Mode and Synchronization

The PS/SYNC pin can be used to select different operation modes. When PS/SYNC is set low and the average inductor current gets lower than about 400mA, Power Save Mode can be enabled and used to improve efficiency.

At this point the converter operates with reduced switching frequency and with a minimum quiescent current to maintain high efficiency. When the load increases above the minimum forced inductor current of about 400mA, the device will automatically switch to PWM mode. The Power Save Mode can be disabled by programming the PS/SYNC high. Connecting a clock signal at PS/SYNC can force the RTQ1741A switching frequency to synchronize to the connected clock frequency. The PS/SYNC input supports standard logic thresholds and the frequency range is between 2.2MHz to 2.6MHz.

### Dynamic Current Limit

To protect the device and the application, the peak inductor current is limited internally on the IC. At nominal operating conditions, this current limit is constant. The current limit value can be found in the electrical characteristics table. If the supply voltage at VIN drops below 2.3V, the current limit is reduced. This can happen when the input power source becomes weak. Increasing output impedance, when the batteries are almost discharged, or an additional heavy

pulse load is connected to the battery can cause the VIN voltage to drop. The dynamic current limit has its lowest value when reaching the minimum recommended supply voltage at VIN.

### Soft-Start and Short Circuit Protection

After being enabled, the device starts operating. The current limit ramps up from an initial 1A following the output voltage increasing. At an output voltage of about 1.2V, the current limit is at its nominal value. If the output voltage does not increase, the current limit will not increase. There is no timer implemented. Thus, the output voltage overshoot at startup, as well as the inrush current, is kept at a minimum. The device ramps up the output voltage in a controlled manner even if a large capacitor is connected at the output. When the output voltage does not increase above 1.2V, the device assumes a short circuit at the output, and keeps the current limit low to protect itself and the application. At a short on the output during operation, the current limit also is decreased accordingly.

### Protection

Additional protections of the RTQ1741A include current overload protection, output over-voltage clamp, and thermal shutdown. To protect the device from overheating, the device has a built-in temperature sensor which monitors the internal junction temperature. If the temperature exceeds a threshold, the device stops operating. As soon as the IC temperature decreases below the threshold with a hysteresis, it starts operating again. The built-in hysteresis is designed to avoid unstable operation at IC temperatures near the over-temperature threshold.

### Under-Voltage Lockout

The under-voltage lockout circuit prevents the device from operating incorrectly at low input voltages. It prevents the converter from turning on the power switches under undefined conditions and prevents the battery from deep discharge. PVIN voltage must be greater than 1.7V to enable the converter. During operation, if PVIN voltage drops below 1.6V, the converter is disabled until the supply exceeds the UVLO rising threshold. The RTQ1741A automatically restarts if the input voltage recovers to the input voltage UVLO high level.

### Inductor Selection

To properly configure the Buck-Boost converter, an inductor must be connected between the LX1 and LX2 pins. To estimate the inductance value, two equations are listed as below :

$$L1 > \frac{V_{OUT} \times (V_{IN(MAX)} - V_{OUT})}{f \times \Delta I_L \times V_{IN(MAX)}} \quad (H)$$

$$L2 > \frac{V_{IN(MIN)} \times (V_{OUT} - V_{IN(MIN)})}{f \times \Delta I_L \times V_{OUT}} \quad (H)$$

where f is the minimum switching frequency. L1 is the minimum inductor value for Buck mode operation. VIN(MAX) is the maximum input voltage. L2 is the minimum inductance for Boost mode operation. VIN(MIN) is the minimum input voltage. The recommended minimum inductor value is either L1 or L2 whichever is higher. For example, a suitable inductor value is 2.2μH for generating a 3.3V output voltage from a Li-Ion battery with the range from 2.5V to 4.2V. The recommended inductor value range is between 1.5μH and 4.7μH. In general, a higher inductor value offers better performance in high voltage conversion condition.

**Table 1. Inductor Suggestion**

Vendor	Inductor Series
Taiyo Yuden	NRS5024T2R2NMGJ

### Output Capacitor Selection

The output capacitor selection determines the output voltage ripple and transient response. It is recommended to use ceramic capacitors placed as close as possible to the VOUT and GND pins of the IC. If, for any reason, the application requires the use of large capacitors which can not be placed close to the IC, using a small ceramic capacitor in parallel to the large one is recommended. This small capacitor should be placed as close as possible to the VOUT and GND pins of the IC. The output voltage ripple for a given output capacitor is expressed as follows :

$$\Delta V_{OUT, \text{ peak (Buck)}} = \frac{V_{OUT} \times (V_{IN} - V_{OUT})}{V_{IN} \times 8 \times L \times (f_{OSC})^2 \times C_{OUT}}$$

$$\Delta V_{OUT, \text{ peak (Boost)}} = \frac{I_{LOAD} \times (V_{OUT} - V_{IN})}{C_{OUT} \times V_{OUT} \times f_{OSC}}$$

If the RTQ1741A operates in Buck mode, the worst-case voltage ripple occurs at the highest input voltage. When the RTQ1741A operates in Boost mode, the worst-case voltage ripple occurs at the lowest input voltage.

The maximum voltage of overshoot or undershoot, is inversely proportional to the value of the output capacitor. To ensure stability and excellent transient response, it is recommended to use a minimum of 100µF X7R capacitors at the output. For surface mount applications, Taiyo Yuden or TDK ceramic capacitors, X7R series Multi-layer Ceramic Capacitor is recommended.

A capacitor with a value in the range of the calculated minimum should be used. This is required to maintain control loop stability. There are no additional requirements regarding minimum ESR. Low ESR capacitors should be used to minimize output voltage ripple. Larger capacitors will cause lower output voltage ripple as well as lower output voltage drop during load transients.

**Thermal Considerations**

The junction temperature should never exceed the absolute maximum junction temperature  $T_{J(MAX)}$ , listed under Absolute Maximum Ratings, to avoid permanent damage to the device. The maximum allowable power dissipation depends on the thermal resistance of the IC package, the PCB layout, the rate of surrounding airflow, and the difference between the junction and ambient temperatures. The maximum power dissipation can be calculated using the following formula :

$$P_{D(MAX)} = (T_{J(MAX)} - T_A) / \theta_{JA}$$

where  $T_{J(MAX)}$  is the maximum junction temperature,  $T_A$  is the ambient temperature, and  $\theta_{JA}$  is the junction-to-ambient thermal resistance.

For continuous operation, the maximum operating junction temperature indicated under Recommended Operating Conditions is 125°C. The junction-to-ambient thermal resistance,  $\theta_{JA}$ , is highly package dependent. For a WDFN-14AL 4x3 package, the thermal resistance,  $\theta_{JA}$ , is 28.6°C/W on a standard JEDEC 51-7 high effective-thermal-conductivity four-layer test board. The maximum power dissipation at  $T_A = 25^\circ\text{C}$  can be calculated as below :

$$P_{D(MAX)} = (125^\circ\text{C} - 25^\circ\text{C}) / (28.6^\circ\text{C/W}) = 3.49\text{W for a WDFN-14AL 4x3 package.}$$

The maximum power dissipation depends on the operating ambient temperature for the fixed  $T_{J(MAX)}$  and the thermal resistance,  $\theta_{JA}$ . The derating curves in Figure 1 allows the designer to see the effect of rising ambient temperature on the maximum power dissipation.

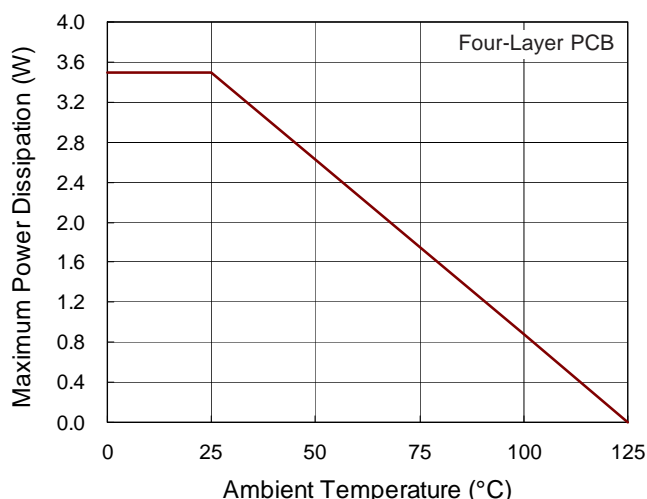
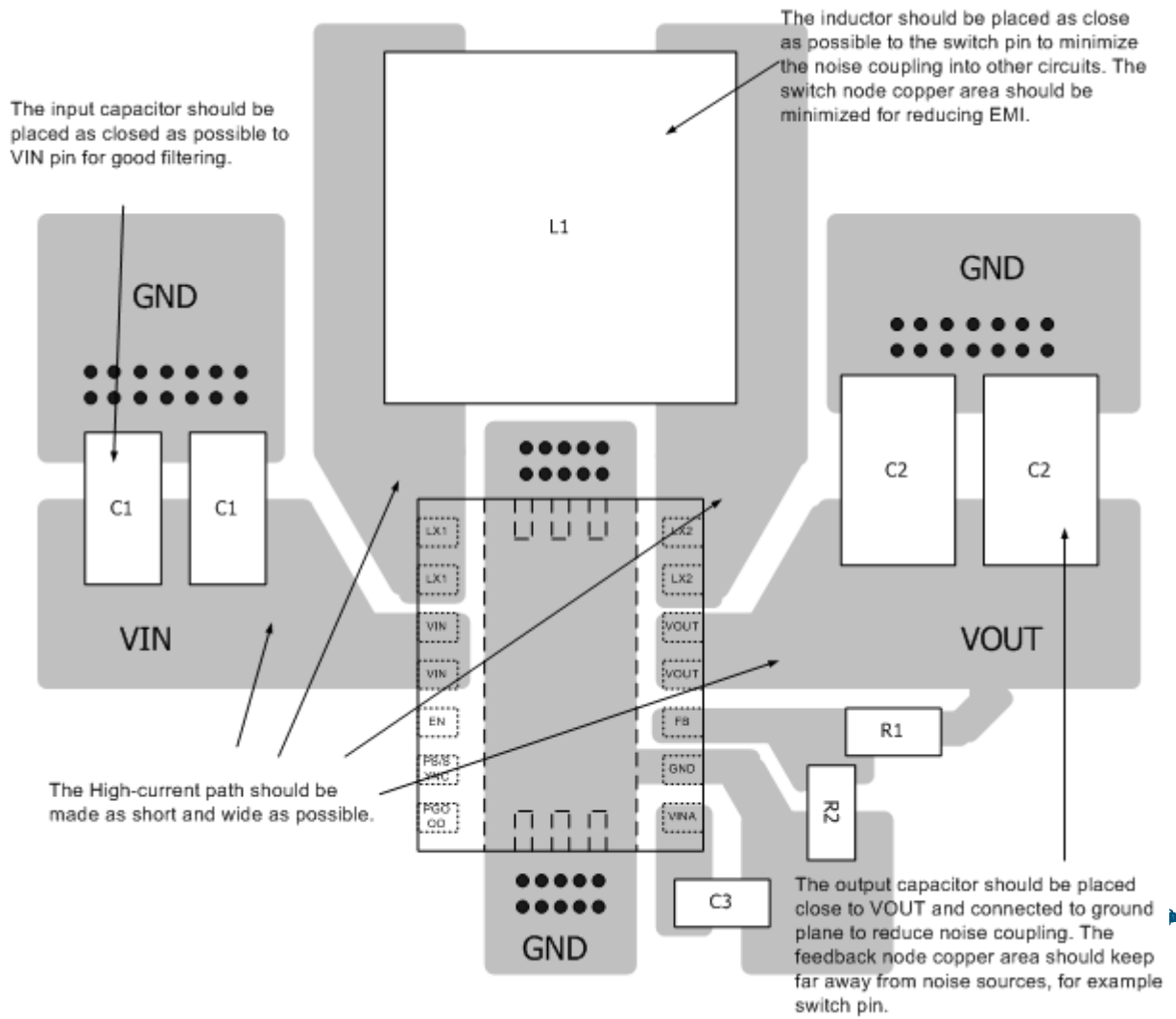

Figure 1. Derating Curve of Maximum Power Dissipation

**Layout Considerations**

For the best performance, the following PCB Layout guidelines must be strictly followed.

- ▶ Place the input and output capacitors as close as possible to the input and output pins.
- ▶ Keep the main power traces as wide and short as possible.
- ▶ Connect the GND and Exposed Pad to a strong ground plane for maximum thermal dissipation and noise protection.
- ▶ Switch node experiences high frequency voltage swings and should be kept in a small area. Keep analog components away from the switch node to prevent stray capacitive noise pick-up.



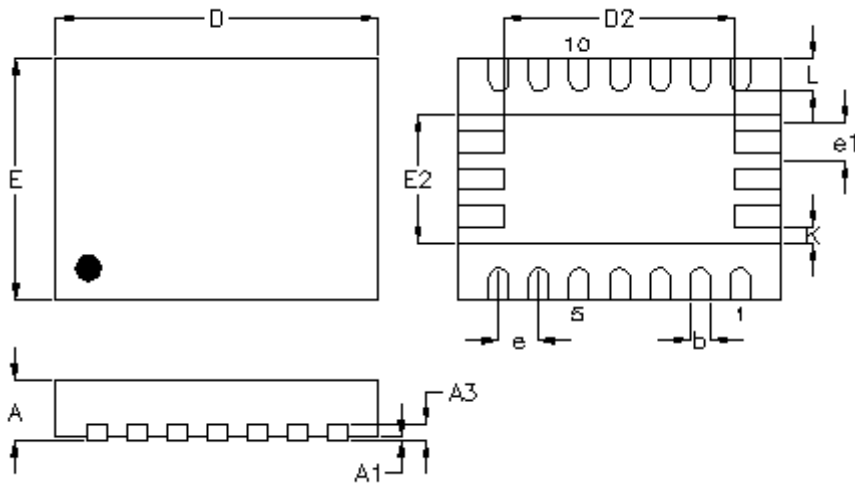

### DETAIL A

Pin #1 ID and Tie Bar Mark Options

Note : The configuration of the Pin #1 identifier is optional, but must be located within the zone indicated.

Symbol	Dimensions In Millimeters		Dimensions In Inches	
	Min	Max	Min	Max
A	0.700	0.800	0.028	0.031
A1	0.000	0.050	0.000	0.002
A3	0.175	0.250	0.007	0.010
b	0.200	0.300	0.008	0.012
D	3.900	4.100	0.154	0.161
D2	2.800	2.900	0.110	0.114
E	2.900	3.100	0.114	0.122
E2	1.530	1.630	0.060	0.064
e	0.500		0.020	
e1	0.460		0.018	
K	0.150	0.250	0.006	0.010
L	0.350	0.450	0.014	0.018

## Footprint Information

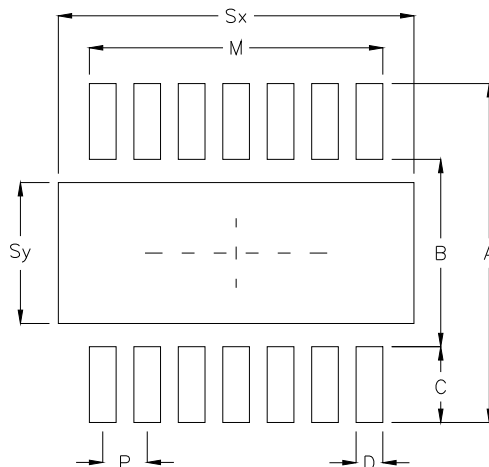

Package	Number of Pin	Footprint Dimension (mm)								Tolerance
		P	A	B	C	D	Sx	Sy	M	
V/W/U/XDFN4x3-14A	14	0.50	3.80	2.10	0.85	0.30	4.00	1.58	3.30	±0.05

### Richtek Technology Corporation

14F, No. 8, Tai Yuen 1<sup>st</sup> Street, Chupei City

Hsinchu, Taiwan, R.O.C.

Tel: (8863)5526789

Richtek products are sold by description only. Richtek reserves the right to change the circuitry and/or specifications without notice at any time. Customers should obtain the latest relevant information and data sheets before placing orders and should verify that such information is current and complete. Richtek cannot assume responsibility for use of any circuitry other than circuitry entirely embodied in a Richtek product. Information furnished by Richtek is believed to be accurate and reliable. However, no responsibility is assumed by Richtek or its subsidiaries for its use; nor for any infringements of patents or other rights of third parties which may result from its use. No license is granted by implication or otherwise under any patent or patent rights of Richtek or its subsidiaries.