

Automotive CIS/CCM PMIC for Ultra Compact Camera and High Image Quality System

General Description

The RTQ2072 is an integrated PMIC with three step down converters and one high PSRR low-dropout (LDO) regulator for automotive camera applications. The high-voltage step down converter is operated with input voltage range up to 18.5V for Power Over Coax (POC) connection. Two low-voltage step down converters provide constant output voltage. All step down converters operate in a forced fixed-frequency PWM mode. The LDO output voltage is easily set via an external resistor. The RTQ2072 provides 10 power sequences by a resistor for flexibility. The RTQ2072 is available in a WETD-VQFN-16L 3x3 package with dimple lead type wettable flanks.

Ordering Information

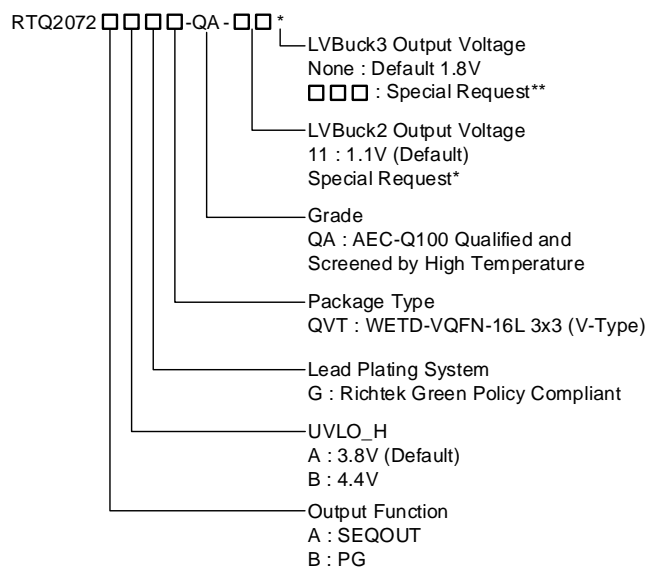

Note :

*Special Request : Available voltage between 0.6V to 2.1V with 100mV step under specific business agreement.

**Special Request : For example, 095 means 0.95V.

Richtek products are Richtek Green Policy compliant and compatible with the current requirements of IPC/JEDEC J-STD-020

Features

- **AEC-Q100 Grade 1**
- **FMEA Compliant Pin Placement and Protection Mechanisms**
- **Three Step-Down Converters (HVBuck1, LVBuck2 and LVBuck3)**
 - ▶ **Peak Current Mode PWM Operation**
 - ▶ **Fixed Switching Frequency at 2.1MHz**
 - ▶ **EMI Reduction with Spread Spectrum and Phase Shift**
 - ▶ **HVBuck1 Input Voltage from 4V to 18.5V, Adjustable Output Voltage and Up to 2A Output Current**
 - ▶ **LVBuck2 Input Voltage from 2.7V to 5V, Fixed Output Voltage and 1.5A Output Current**
 - ▶ **LVBuck3 Input Voltage from 2.7V to 5V, Fixed Output Voltage and 750mA Output Current**
 - ▶ **Pins Related to LVBuck2/LVBuck3 Allowable Floating if Channel Unused**
- **Low Dropout Regulator (LDO)**
 - ▶ **Input Voltage from 2.7V to 5V and 300mA Output Current**
 - ▶ **10 Adjustable Output Voltage Settings via RSET Pin**
 - ▶ **High PSRR : 60dB at 100kHz, 40dB at 1MHz**
- **Output Function**
 - ▶ **Sequence Control for External Power IC via SEQOUT (RTQ2072A-QA)**
 - ▶ **Power Status Indication via PG (RTQ2072B-QA)**
- **10 Flexible Power Sequence Settings via SEQ Pin**
- **Small Form Factor WETD-VQFN-16L 3x3 Wettable Flanks Package**

Applications

- Automotive Camera Modules
 - ▶ Surround View Camera
 - ▶ Front View Camera
 - ▶ Rear View Camera
 - ▶ Dash Cam DVR
 - ▶ Driver Monitoring System
 - ▶ Cabin Monitor
 - ▶ eMirror

Marking Information

RTQ2072BAGQVT-QA-11

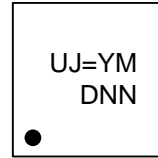

UJ= : Product Code
YMDNN : Date Code

Pin Configuration

(TOP VIEW)

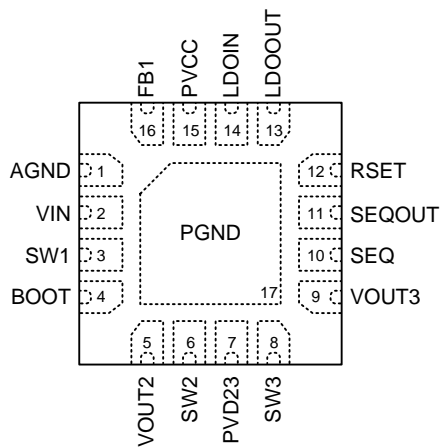

WETD-VQFN-16L 3x3 (RTQ2072A-QA)

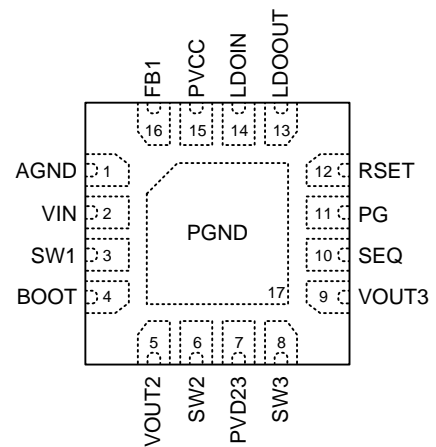

WETD-VQFN-16L 3x3 (RTQ2072B-QA)

Simplified Application Circuit

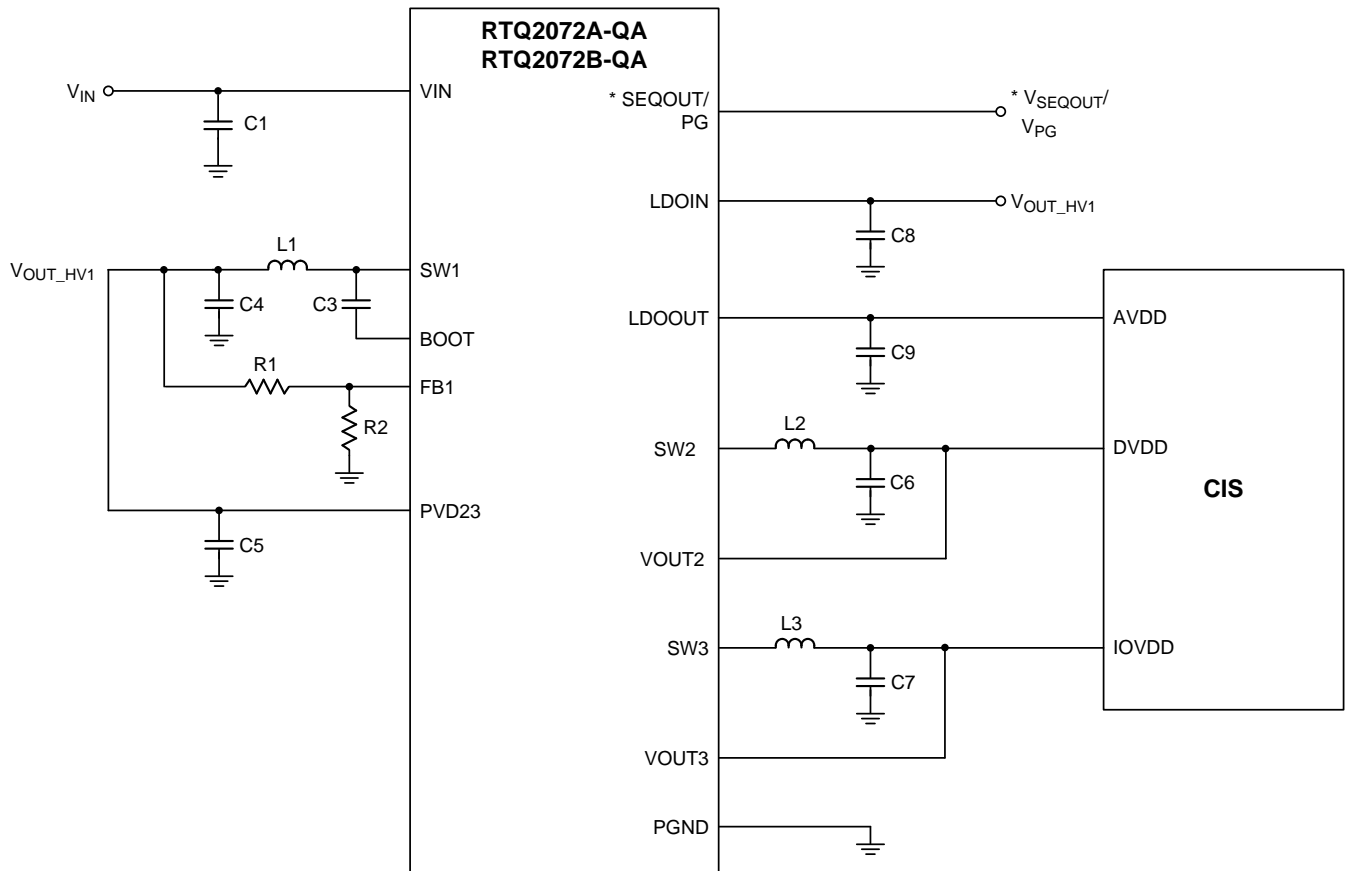

* SEQOUT pinout is for RTQ2072A-QA; PG pinout is for RTQ2072B-QA.

Functional Pin Description

Pin No.	Pin Name	Pin Function
1	AGND	Analog ground.
2	VIN	Supply voltage input of HVBuck1. Connect a 4.7 μ F or larger decouple ceramic capacitor between this pin and ground.
3	SW1	HVBuck1 switch node.
4	BOOT	Bootstrap capacitor connection pin for HVBuck1. Connect a 0.1 μ F ceramic capacitor between this pin and SW1.
5	VOUT2	Output voltage feedback input of LVBuck2. Directly connect the output capacitor node to this pin for better regulation.
6	SW2	LVBuck2 switch node.
7	PVD23	Supply voltage input of LVBuck2 and LVBuck3. Connect a 4.7 μ F or larger decouple ceramic capacitor between this pin and ground.
8	SW3	LVBuck3 switch node.

Pin No.	Pin Name	Pin Function
9	VOUT3	Output voltage feedback input of LVBuck3. Directly connect the output capacitor node to this pin for better regulation.
10	SEQ	Power sequence selection.
11	SEQOUT	Sequence control output with open drain structure for external power IC. (RTQ2072A-QA)
	PG	Power status indication pin with open drain structure for HVBuck1, LVBuck2, LVBuck3 and LDO. PG at high state indicates all outputs work well. (RTQ2072B-QA)
12	RSET	LDO output voltage selection.
13	LDOOUT	LDO output. Connect a 2.2 μ F ceramic decouple capacitor between this pin and ground.
14	LDOIN	Supply voltage input of LDO. Connect a 2.2 μ F or larger decouple ceramic capacitor between this pin and ground.
15	PVCC	Internal analog power output. Connect a 1 μ F ceramic decouple capacitor between this pin and ground. Note additional external loading on this pin is forbidden.
16	FB1	Output voltage feedback input of HVBuck1.
17 (Exposed Pad)	PGND	IC thermal pad and power ground. It must connect to main ground plane for proper operation.

Functional Block Diagram

RTQ2072A-QA

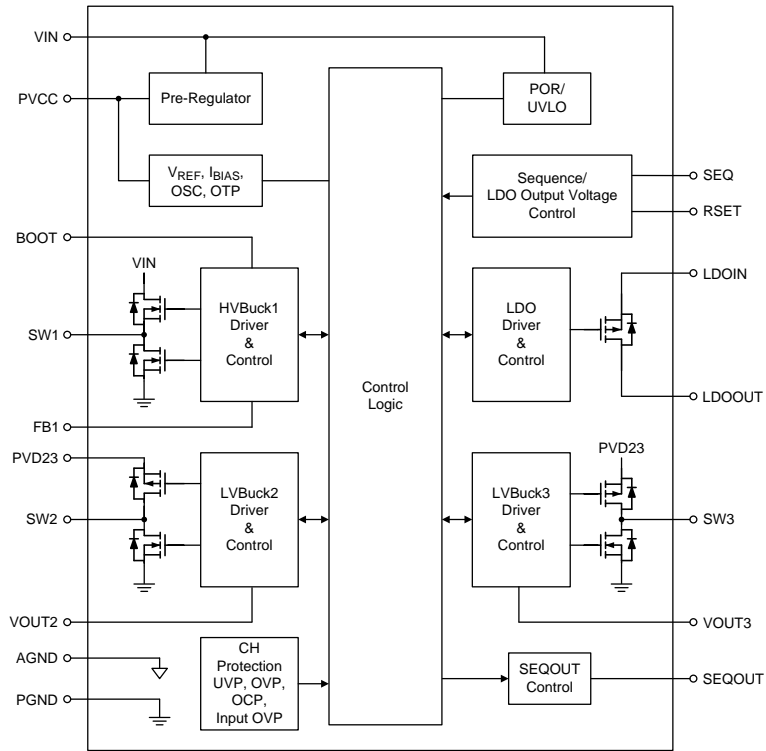

RTQ2072B-QA

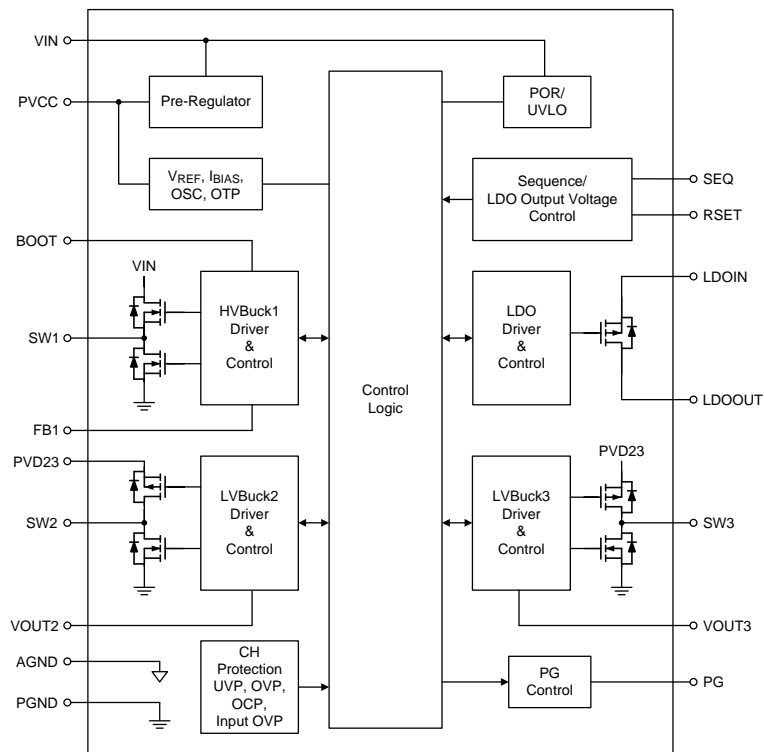

Operation

The RTQ2072A-QA/RTQ2072B-QA is a highly integrated power-management integrated circuit (PMIC) for automotive camera system, which includes three step-down converters (CH1 HVBUCK1, CH2 LVBUCK2, CH3 LVBUCK3) and one generic LDO (CH4 LDO).

System Under-Voltage Protection and Over-Voltage Protection

The RTQ2072A-QA/RTQ2072B-QA stops operating if V_{IN} voltage falls below the Under-Voltage Lock Out level (UVLO_L). There is a typical 500mV hysteresis implemented to avoid unstable on/off behaviors. The shift values of UVLO_H and UVLO_L both toward to the same direction. (To positive or negative at the same time.) The device is initialized in its default state after V_{IN} voltage recovering from UVLO_H. When V_{IN} voltage reaches the Over-Voltage Protection level, the step-down converters, LDO and SEQOUT (RTQ2072A-QA) are disabled immediately. Then the IC enters into latch off state and only can re-start with V_{IN} ON/OFF. Meanwhile, the PG status will be also set to 0V to indicate IC fault condition.

Thermal Protection

The RTQ2072A-QA/RTQ2072B-QA features an over-temperature protection (OTP). When the junction temperature is higher than 160°C typical value, OTP is triggered to disable all outputs and the device enters into a latch off state. When the RTQ2072A-QA/RTQ2072B-QA recovers from OTP, the device only can re-start with V_{IN} ON/OFF.

Pre-Regulator

The device integrates a 4.45V linear regulator (PVCC) supplied by V_{IN} to provide power to the internal circuitry. The PVCC can be used as the RSET and SEQ pull-up supply but it is “NOT” allowed to power other device or circuitry. A 1 μ F decoupling capacitor must be connected between PVCC and AGND to filter the noise and it needs to be placed as close as possible to the PVCC pin.

Peak Current Mode Control

The three step-down converters utilize the peak current mode control. An internal oscillator initiates turn-on of the high-side MOSFET switch. At the beginning of each clock cycle, the internal high-side MOSFET switch turns on, allowing current to ramp up in the inductor. With comparisons of the inductor peak current signal during high-side MOSFET switch on interval and the internal compensation signal derived from the sensed feedback voltage with reference voltage, the high-side MOSFET switch is turned off and inductor current continues to flow through the low-side MOSFET switch. This cycle repeats at the next clock cycle. In this way, the regulated inductor current controls duty-cycle and output voltage of the converter.

Spread-Spectrum Operation

Due to the periodicity of the switching signal, the energy concentrates in one particular frequency and its harmonics. The energy is radiated and possible to result in a potential EMI issue. The RTQ2072A-QA/RTQ2072B-QA equips a spread-spectrum function to meet CISPR and automotive EMI compliances. The spread-spectrum function is implemented by a pseudo random sequence and uses +6% spread of the switching frequency. For example, when the switching frequency typical value is 2.1MHz, the frequency range varies from 2.1MHz to 2.226MHz. Therefore, the RTQ2072A-QA/RTQ2072B-QA can guarantee that the 2.1MHz switching frequency does not drop into the 1.8MHz AM band limit.

Phase-Shifted Operation

The RTQ2072A-QA/RTQ2072B-QA supports phase shift operations among the step-down converters for further easing the simultaneous switching energy radiation quantity. The internal clock is automatically shifted to different respective sub-clocks for step-down converters. For example, when two step-down converters application, the beginning turn-on time between two high-side MOSFETs will have a 180-degree phase difference. Likewise, a 120-degree phase difference when three step-down converters.

Allowable Channel Floating

For saving PCB layout space and material cost, the unused low-voltage step-down converter (CH2/CH3) is allowable to pin (SW2/SW3) floating without any inductor and output capacitor placement. The pin PVD23 is required to connect to a fixed voltage for floating detection and it is allowable without capacitor placement. The RTQ2072A-QA/RTQ2072B-QA automatically detects pin status during power-on procedure to determine whether the channel is used or not. In addition, the related failures on unused channels do not affect the device operation.

Power Good Indication

The RTQ2072B-QA features an open-drain power-good output (PG) to monitor the output voltage status.

Connect a pull-up resistor from PG pin to an external voltage. Note it is forbidden to use PVCC as pulled-up voltage of PG pin. When the last channel of power-on sequence reaches 90% of its target output voltage, the PG signal is pulled up to indicate “Power Good” status after 10ms tills to device disabled or any other protection happens.

External Control Output

The RTQ2072A-QA features an open-drain external control output (SEQOUT) for external device. Connect a pull-up resistor from SEQOUT pin to an external voltage. Note it is forbidden to use PVCC as pulled-up voltage of SEQOUT pin. Referring to Table 3 for further information about power-on sequence.

Table 1. Unused Channel Pin Connection

Unused Channel	Unused Pin Number	Unused Pin Name	Pin Configuration
LVBuck2	5	VOUT2	Floating
	6	SW2	Floating
	7	PVD23	Connect to a fixed voltage
LVBuck3	7	PVD23	Connect to a fixed voltage
	8	SW3	Floating
	9	VOUT3	Floating

Absolute Maximum Ratings (Note 1)

- VIN ----- -0.3V to 24V
- SW1 ----- -0.3V to 24V
- BOOT ----- -0.3V to 28V
- BOOT to SW1 ----- -0.3V to 5V
- VOUT2, PVD23, VOUT3, SEQ, SEQOUT (RTQ2072A-QA),
PG (RTQ2072B-QA), RSET, LDOOUT, LDOIN, PVCC, FB1 ----- -0.3V to 6.5V
- SW2, SW3 ----- -0.3V to 6.5V
- Power Dissipation, PD @ TA = 25°C
WETD-VQFN-16L 3x3 ----- 4.16W
- Package Thermal Resistance (Note 2)
WETD-VQFN-16L 3x3, θ_{JA} ----- 30°C/W
WETD-VQFN-16L 3x3, θ_{JC} ----- 4.4°C/W
- Lead Temperature (Soldering, 10 sec.) ----- 260°C
- Junction Temperature ----- 150°C
- Storage Temperature Range ----- -65°C to 150°C
- ESD Susceptibility (Note 3)
HBM (Human Body Model) ----- 2kV

Recommended Operating Conditions (Note 4)

- Supply Voltage, VIN ----- 4V to 18.5V
- Supply Voltage, VPVD23, VLDOIN ----- 2.7V to 5V
- Ambient Temperature Range ----- -40°C to 125°C
- Junction Temperature Range ----- -40°C to 150°C

Electrical Characteristics

(TA = TJ = -40°C to 125°C, VIN = 6V, VOUT_HV1 = 3.6V, VOUT_LV2 = 1.1V, VOUT_LV3 = 1.8V, VOUT_LDO = 3.3V, unless otherwise specified)

Parameter	Symbol	Test Conditions	Min	Typ	Max	Unit
System						
Under-Voltage Lockout Threshold	UVLO_H	VIN rising	3.6	3.8	4	V
	UVLO_L	VIN falling	3.15	3.3	3.45	V
Input Over-Voltage Protection	VIN_OV		18.6	20	21.5	V
CH1 HVBuck1						
Input Voltage Range	VIN		4	--	18.5	V
Output Voltage Range	VOUT_HV1	Buck mode operation. Switching frequency, minimum on time and minimum off time need to be considered.	2.7	--	5	V

Parameter	Symbol	Test Conditions	Min	Typ	Max	Unit
Output Feedback Voltage Accuracy	V _{FB1}		0.788	0.8	0.812	V
Switching Frequency	f _{SW_HV1}		1.89	2.1	2.31	MHz
Spread-Spectrum Range	SS _{HV1}		--	6	--	%
Switching Minimum On Time	t _{ON_MIN_HV1}		--	--	55	ns
Switching Minimum Off Time	t _{OFF_MIN_HV1}		--	--	50	ns
High-Side MOSFET On Resistance	R _{ON_HS_HV1}	From VIN pin to SW1 pin	115	210	340	mΩ
Low-Side MOSFET On Resistance	R _{ON_LS_HV1}	From SW1 pin to PGND pin	40	110	200	mΩ
Inductor Peak Current Limit	I _{CL_PK_HV1}		2.4	3	3.6	A
Inductor Valley Current Limit	I _{CL_VL_HV1}		--	2.7	--	A
Negative Inductor Peak Current Limit	I _{CL_NPK_HV1}		1	2.5	4	A
Output Discharge Resistor	R _{DIS_HV1}		220	270	360	Ω
Output Under-Voltage Falling Threshold	U _{VP_F_HV1}		40	50	60	%
Output Feedback Over-Voltage Rising Threshold	O _{VP_R_HV1}		--	110	--	%
CH2 LV Buck2 (V_{IN_PVD23} = 3.6V)						
Input Voltage Range	V _{IN_PVD23}		2.7	--	5	V
Output Voltage	V _{OUT_LV2}		--	1.1	--	V
Output Voltage Accuracy	V _{OUT_ACC_LV2}		-1.5	--	1.5	%
Switching Frequency	f _{SW_LV2}		1.89	2.1	2.31	MHz
Spread-Spectrum Range	SS <sub_lv2< sub=""></sub_lv2<>		--	6	--	%
Switching Minimum On Time	t _{ON_MIN_LV2}		--	--	44	ns
High-Side MOSFET On Resistance	R _{ON_HS_LV2}	From PVD23 pin to SW2 pin	110	150	215	mΩ
Low-Side MOSFET On Resistance	R _{ON_LS_LV2}	From SW2 pin to PGND pin	60	90	145	mΩ
Inductor Peak Current Limit	I _{CL_PK_LV2}		1.8	2.2	2.6	A

Parameter	Symbol	Test Conditions	Min	Typ	Max	Unit
Inductor Valley Current Limit	ICL_VL_LV2		--	1.8	--	A
Negative Inductor Peak Current Limit	ICL_NPK_LV2		0.7	1.7	2.9	A
Output Discharge Resistor	RDIS_LV2		6	9	14	Ω
Output Under-Voltage Falling Threshold	UVP_F_LV2		40	50	60	%
Output Over-Voltage Rising Threshold	OVP_R_LV2		--	120	--	%
Output Over-Voltage Falling Threshold	OVP_F_LV2		--	110	--	%
Input Over-Voltage Rising Threshold	OVP_IN_R_LV2		5.35	5.8	6.25	V
Input Over-Voltage Hysteresis	OVP_IN_HYS_LV2	VIN_PVD23 falling	--	580	--	mV
CH3 LVBuck3 (VIN_PVD23 = 3.6V)						
Input Voltage Range	VIN_PVD23		2.7	--	5	V
Output Voltage	VOUT_LV3		--	1.8	--	V
Output Voltage Accuracy	VOUT_ACC_LV3		-1.5	--	1.5	%
Switching Frequency	fsw_LV3		1.89	2.1	2.31	MHz
Spread-Spectrum Range	SS_LV3		--	6	--	%
Switching Minimum On Time	ton_MIN_LV3		--	--	44	ns
High-Side MOSFET On Resistance	RON_HS_LV3	From PVD23 pin to SW3 pin	240	310	440	m Ω
Low-Side MOSFET On Resistance	RON_LS_LV3	From SW3 pin to PGND pin	170	230	360	m Ω
Inductor Peak Current Limit	ICL_PK_LV3		0.96	1.2	1.44	A
Inductor Valley Current Limit	ICL_VL_LV3		--	1.08	--	A
Negative Inductor Peak Current Limit	ICL_NPK_LV3		0.7	1.7	2.9	A
Output Discharge Resistor	RDIS_LV3		7	10	15	Ω
Output Under-Voltage Falling Threshold	UVP_F_LV3		40	50	60	%

Parameter	Symbol	Test Conditions	Min	Typ	Max	Unit
Output Over-Voltage Rising Threshold	OVP_R_LV3		--	120	--	%
Output Over-Voltage Falling Threshold	OVP_F_LV3		--	110	--	%
Input Over-Voltage Rising Threshold	OVP_IN_R_LV3		5.35	5.8	6.25	V
Input Over-Voltage Hysteresis	OVP_IN_HYS_LV3	VIN_PVD23 falling	--	580	--	mV
CH4 LDO (VIN_LDO = 3.6V)						
Input Voltage Range	VIN_LDO		2.7	--	5	V
Output Voltage Range	VOUT_LDO	VOUT_LDO setting via RSET	1.8	--	3.5	V
Output Voltage Accuracy	VOUT_ACC_LDO	VIN_LDO - VOUT_LDO > 0.3V, IOUT_LDO = 0mA to 300mA	-1.5	--	1.5	%
Maximum Output Current	IOUT_MAX_LDO		300	--	--	mA
Dropout Voltage	VDROP_300_LDO	IOUT_LDO = 300mA (Note 5)	--	--	300	mV
	VDROP_150_LDO	IOUT_LDO = 150mA (Note 5)	--	--	150	
Output Current Limit	ICL_LDO	(Note 6)	345	450	555	mA
Output Discharge Resistor	RDIS_LDO		48	76	104	Ω
Output Under-Voltage Falling Threshold	UVP_F_LDO		30	40	50	%
Output Over-Voltage Rising Threshold	OVP_R_LDO		--	125	--	%
Output Over-Voltage Falling Threshold	OVP_F_LDO		--	110	--	%
Input Over-Voltage Rising Threshold	OVP_IN_R_LDO		5.35	5.8	6.25	V
Input Over-Voltage Hysteresis	OVP_IN_HYS_LDO	VIN_LDO falling	--	500	--	mV
PVCC (Note 7)						
Internal Regulator Output Voltage	VOUT_PVCC		4.33	4.58	4.83	V
Over-Current Limit	ICL_PVCC		150	--	300	mA
SEQOUT (RTQ2072A-QA)						
Output Low Voltage		Current into SEQOUT pin equal to 2mA	--	--	200	mV

Parameter	Symbol	Test Conditions	Min	Typ	Max	Unit
Input Leakage Current	I _{LEAK_SEQOUT}	1.8V applied on SEQOUT pin	--	--	1	μA
Power Good (RTQ2072B-QA)						
Pull Down Voltage	V _{OUT_L_PG}	Current into PG pin equal to 5mA	--	--	200	mV
Input Leakage Current	I _{LEAK_PG}	1.8V applied on PG pin	--	--	1	μA
Timing						
Soft-Start Time	t _{SS_HV1}	Time from V _{OUT_HV1} 0% rise to 90% of target value, no load	500	1000	1500	μs
	t _{SS_LV2}	Time from V _{OUT_LV2} 0% rise to 90% of target value, no load	500	1000	1500	
	t _{SS_LV3}	Time from V _{OUT_LV3} 0% rise to 90% of target value, no load	500	1000	1500	
	t _{SS_LDO}	Time from the previous turn on channel's output voltage reaching 90% of target value to V _{OUT_LDO} rise to 90% of target value. (Note 8)	200	700	1100	
PG Delay Time	t _{DLY_PG}	(RTQ2072B-QA)	9	10	11	ms

System Characteristics

The following specifications are guaranteed by design and are not performed in production testing. (T_A = T_J = -40°C to 125°C, V_{IN} = 6V, V_{OUT_HV1} = 3.6V, V_{OUT_LV2} = 1.1V, V_{OUT_LV3} = 1.8V, V_{OUT_LDO} = 3.3V, unless otherwise specified.)

Parameter	Symbol	Test Conditions	Min	Typ	Max	Unit
System						
Over-Temperature Protection	OTP		--	160	--	°C
Over-Temperature Protection Hysteresis	OTP_H		--	20	--	°C
CH1 HV Buck1						
Maximum Output Current	I _{OUT_MAX_HV1}		2	--	--	A
Load Regulation	V _{LOAD_REG_HV1}	I _{OUT_HV1} = 0A to 2A	--	--	0.1	%/A
Line Regulation	V _{LINE_REG_HV1}	V _{IN} = 5V to 18.5V, I _{OUT_HV1} = 2A	--	--	1	%
Load Transient	V _{LOAD_TRAIN_HV1}	I _{OUT_HV1} = 10mA to 500mA to 10mA, 1μs	-150	--	150	mV
Line Transient	V _{LINE_TRAIN_HV1}	V _{IN} = 5V to 18.5V to 5V, 100μs, I _{OUT_HV1} = 10mA/500mA	-50	--	50	mV
Output Ripple	V _{RIPPLE_HV1}	Peak to peak in one switching cycle	--	--	20	mVpp

Parameter	Symbol	Test Conditions	Min	Typ	Max	Unit
CH2 LVBuck2 (VIN_PVD23 = 3.6V)						
Maximum Output Current	IOUT_MAX_LV2		1.5	--	--	A
Load Regulation	VLOAD_REG_LV2	IOUT_LV2 = 0A to 1.5A	--	--	0.1	%/A
Line Regulation	VLINE_REG_LV2	VIN_PVD23 = 2.7V to 5V, IOUT_LV2 = 1.5A	--	--	1	%
Load Transient	VLOAD_TRAIN_LV2	IOUT_LV2 = 10mA to 500mA to 10mA, 1μs	-50	--	50	mV
Line Transient	VLINE_TRAIN_LV2	VIN_PVD23 = 3V to 5V to 3V, 50μs, IOUT_LV2 = 10mA/1A	-50	--	50	mV
Output Ripple	VRIPPLE_LV2	Peak to peak in one switching cycle	--	--	10	mVpp
CH3 LVBuck3 (VIN_PVD23 = 3.6V)						
Maximum Output Current	IOUT_MAX_LV3		750	--	--	mA
Load Regulation	VLOAD_REG_LV3	IOUT_LV3 = 0A to 750mA	--	--	0.1	%/A
Line Regulation	VLINE_REG_LV3	VIN_PVD23 = 2.7V to 5V, IOUT_LV3 = 750mA	--	--	1	%
Load Transient	VLOAD_TRAIN_LV3	IOUT_LV3 = 10mA to 300mA to 10mA, 1μs	-50	--	50	mV
Line Transient	VLINE_TRAIN_LV3	VIN_PVD23 = 3V to 5V to 3V, 50μs, IOUT_LV3 = 10mA/300mA	-50	--	50	mV
Output Ripple	VRIPPLE_LV3	Peak to peak in one switching cycle	--	--	10	mVpp
CH4 LDO (VIN_LDO = 3.6V)						
Power Supply Rejection Ratio	PSRR_LDO	IOUT_LDO = 100mA, f = 100kHz	--	60	--	dB
		IOUT_LDO = 100mA, f = 1MHz	--	40	--	
Output Noise Voltage	eN_LDO	IOUT_LDO = 100mA, f = 100Hz to 100kHz	--	60	--	μV
Load Transient	VLOAD_TRAIN_LDO	IOUT_LDO = 10mA to 200mA to 10mA, 1μs	-25	--	25	mV
Line Transient	VLINE_TRAIN_LDO	All VOUT_LDO, VIN_LDO step 600mV, LDO not in dropout condition, 10μs, IOUT_LDO = 1mA/300mA	-25	--	25	mV
Component Requirement (Note 4)						
Effective Input Capacitance	CIN_HV1		1.5	4.7	10	μF
	CIN_PVD23		1.5	4.7	10	
	CIN_LDO		0.7	2.2	4	
Effective Output Capacitance	COUT_HV1		3.3	10	14	μF
	COUT_LV2		4.5	10	14	
	COUT_LV3		4.5	10	14	
	COUT_LDO		0.7	2.2	4	

Parameter	Symbol	Test Conditions	Min	Typ	Max	Unit
Output Inductance	LHV1		1	1.5	2	μH
	LLV2		0.68	1	1.2	
	LLV3		0.68	1	1.2	
Effective Boot Capacitance	CBOOT		0.07	0.1	0.13	μF
Effective PVCC Capacitance	CPVCC		0.3	1	1.4	μF

Note 1. Stresses beyond those listed under “Absolute Maximum Ratings” may cause permanent damage to the device. These are stress ratings only, and functional operation of the device at these or any other conditions beyond those indicated in the operational sections of the specifications is not implied. Exposure to absolute maximum rating conditions may affect device reliability.

Note 2. θ_{JA} is measured under natural convection (still air) at $T_A = 25^\circ\text{C}$ with the component mounted on a high effective-thermal-conductivity four-layer test board on a JEDEC 51-7 thermal measurement standard. θ_{JC} is measured at the exposed pad of the package.

Note 3. Devices are ESD sensitive. Handling precautions are recommended.

Note 4. The device is not guaranteed to function outside its operating conditions.

Note 5. Dropout voltage is the voltage difference between the input and the output at which the output voltage drops to 100 mV below its nominal value.

Note 6. It only supports LDO loading smaller than 150mA (typ.) to power up successfully. The current limit changes back to 450mA after LDO rail enabled after 8ms.

Note 7. PVCC is the pre-regulator output voltage only for internal circuitry. External loading on PVCC pin is forbidden.

Note 8. The t_{SS_LDO} depends on LDO total output capacitance. It can calculate the soft-start time without loading condition as formula : $t_{SS_LDO} = (C_{OUT_LDO} \times V_{OUT_LDO}) / 0.15$.

Typical Application Circuit

RTQ2072A-QA

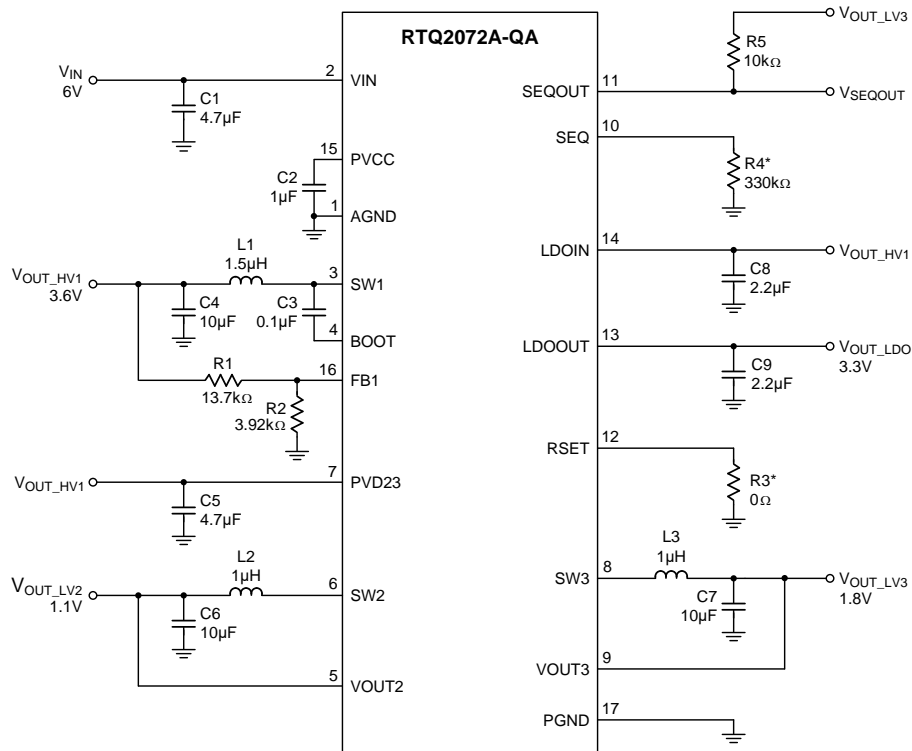

RTQ2072B-QA

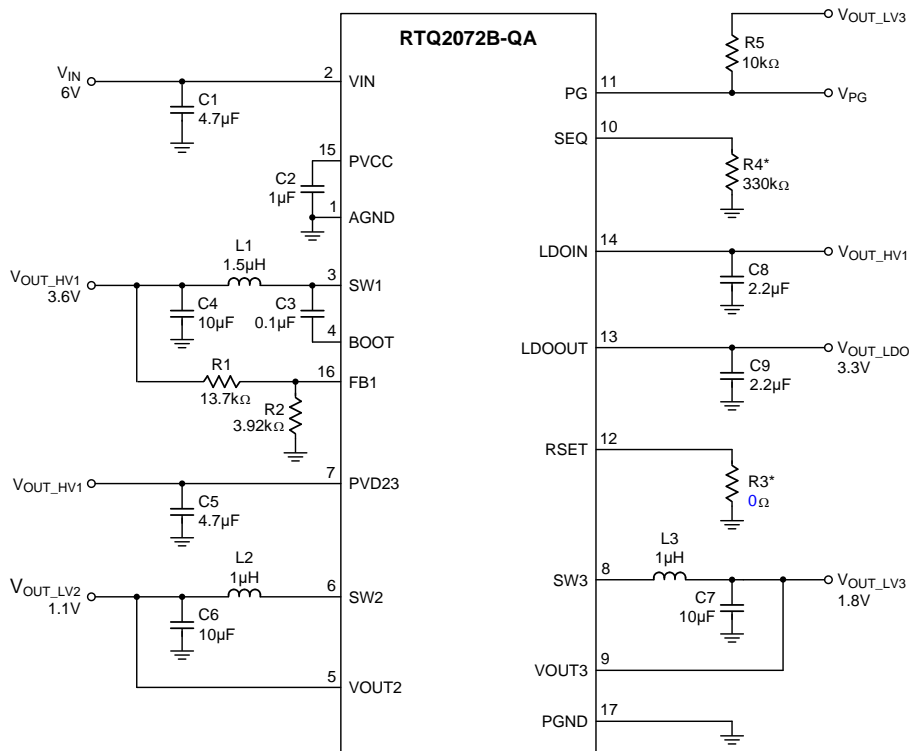

Table 2. Component List of Evaluation Board

Reference	Qty	Part Number	Description	Package	Manufacturer
C1	1	GCJ31CR71E475KA12	4.7 μ F/25V/X7R	1206	MURATA
C2	1	GRT155C81A105KE01	1 μ F/10V/X6S	0402	MURATA
C3	1	GRT155R71C104KE01	0.1 μ F/16V/X7R	0402	MURATA
C4, C6, C7	1	GRT188C81A106ME13	10 μ F/10V/X6S	0603	MURATA
C5	1	GRT188C81C475KE13	4.7 μ F/16V/X6S	0603	MURATA
C8, C9	1	GRT155C81A225KE13	2.2 μ F/10V/X6S	0402	MURATA
L1	1	TFM201610ALMA1R5MTAA	1.5 μ H/3.1A/85m Ω	0806	TDK
L2, L3	1	TFM201610ALMA1R0MTAA	1 μ H/3.7A/50m Ω	0806	TDK
R1	1	MR02X1372FAL	13.7k Ω /1%	0201	WALSIN
R2	1	MR02X3921FAL	3.92k Ω /1%	0201	WALSIN
R3*	1	MR02X000 PAL	0 Ω /Jumper	0201	WALSIN
R4*	1	MR02X3303FAL	330k Ω /1%	0201	WALSIN
R5	1	MR02X1002FAL	10k Ω /1%	0201	WALSIN

R3* : Resistor is adjustable with different LDO output voltages.

R4* : Resistor is adjustable with different power on sequences.

Typical Operating Characteristics

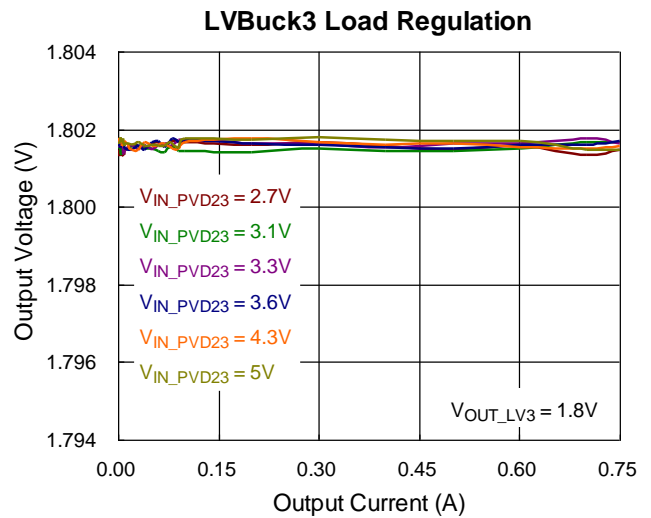
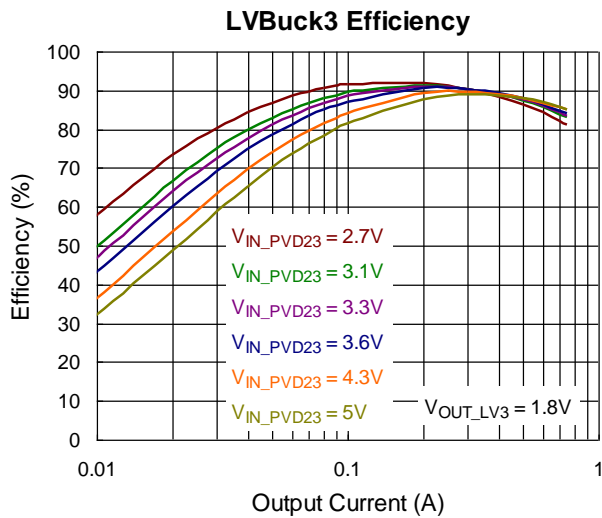
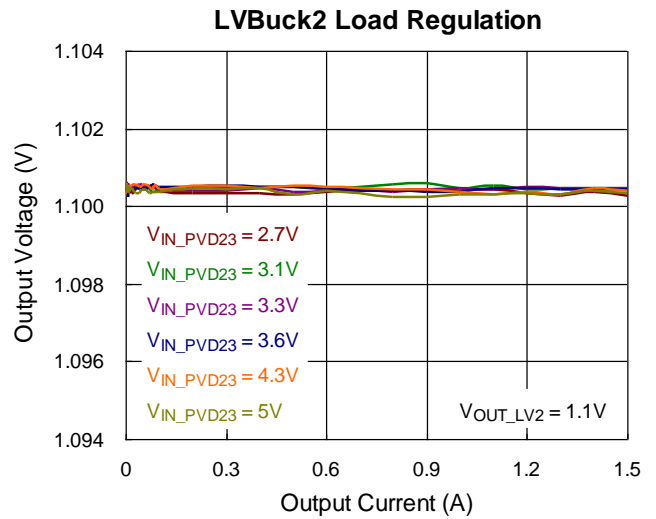
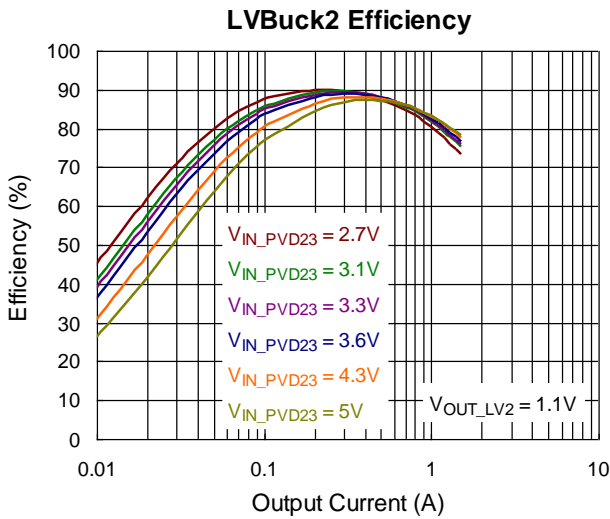
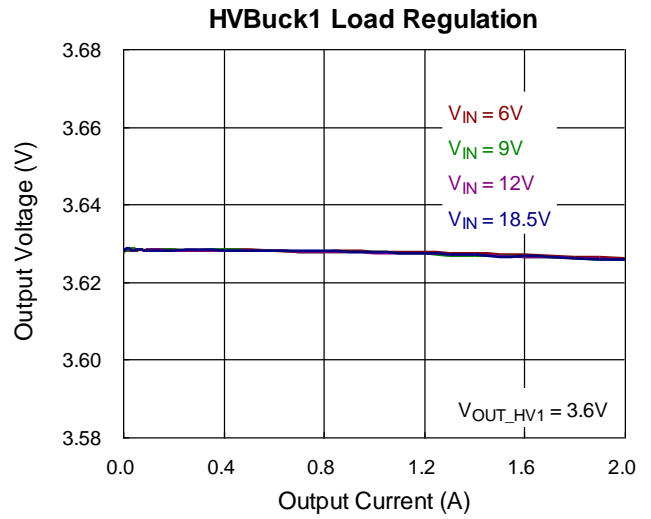
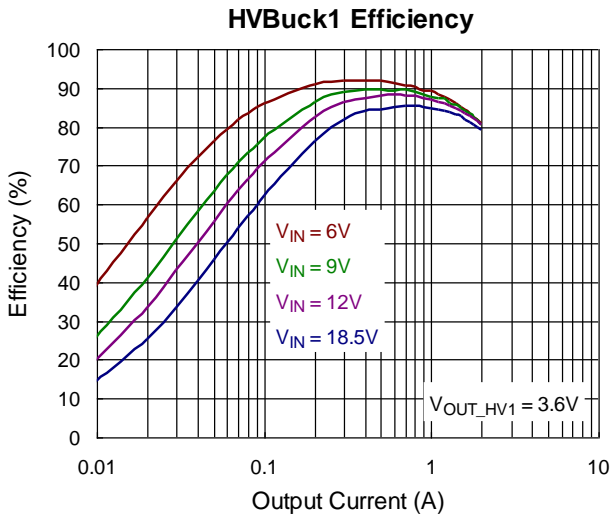

LDO Load Regulation

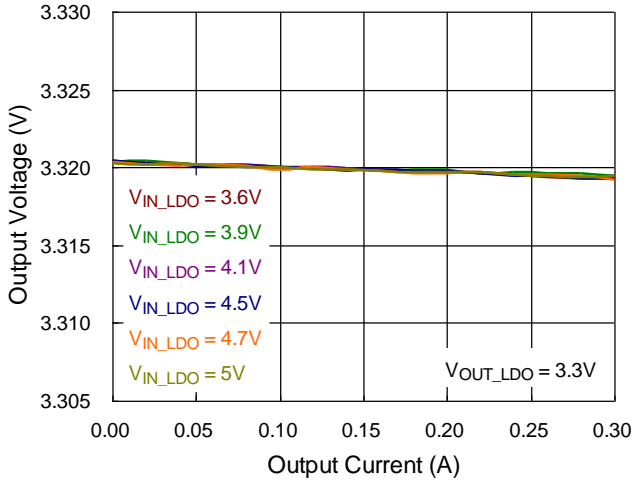

LDO Dropout Voltage vs. Output Current

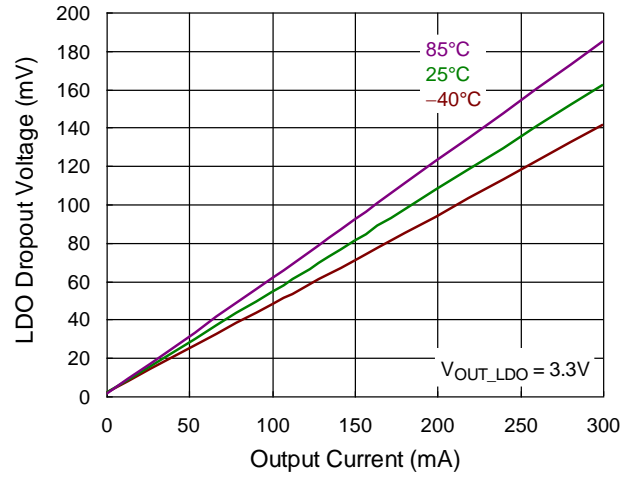

LDO PSRR

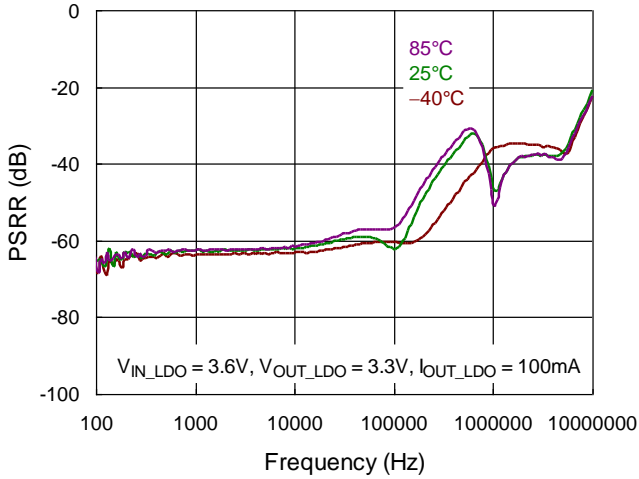

LDO Output Noise

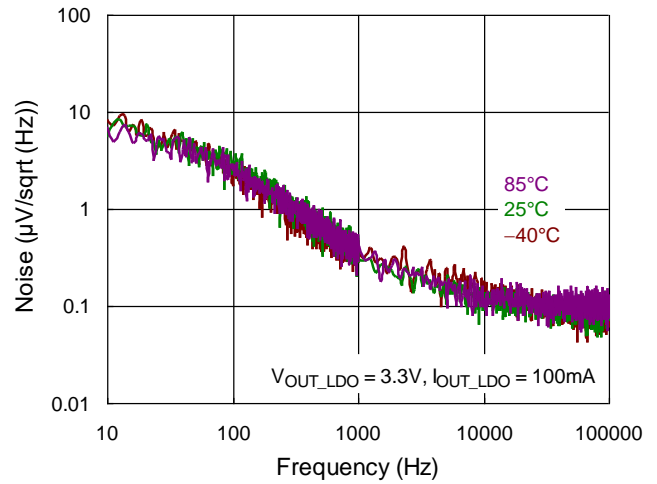

SEQ9 Power On

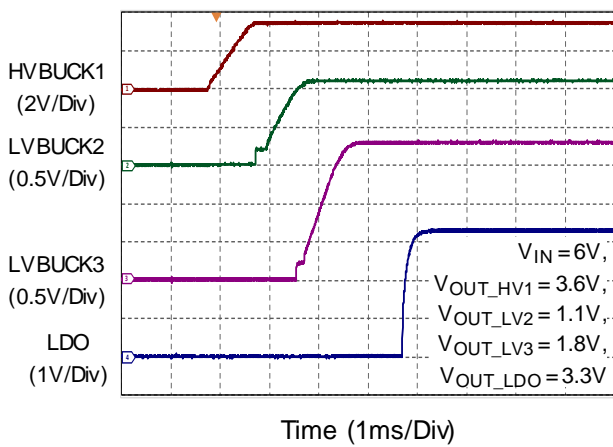

SEQ9 Power Off

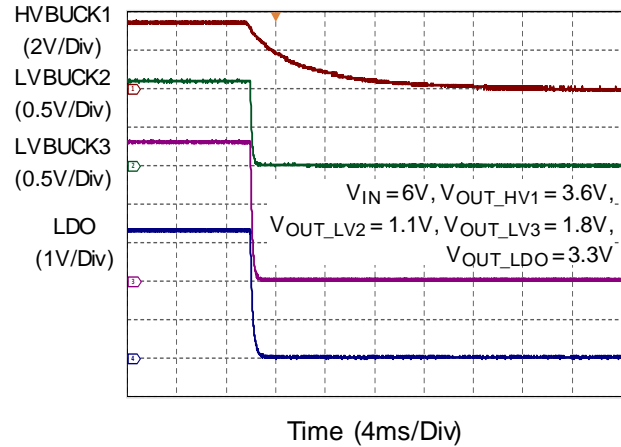

Application Information

Richtek's component specification does not include the following information in the Application Information section. Thereby no warranty is given regarding its validity and accuracy. Customers should take responsibility to verify their own designs and reserve suitable design margin to ensure the functional suitability of their components and systems.

Power Sequence Control

The RTQ2072A-QA/RTQ2072B-QA supports 10 power-on sequences for the step-down converters and LDO via the dedicated resistor on SEQ pin. SEQ pin is not allowable at floating state and resistance selected out of range is not guaranteed to correct power-on sequence. In addition, there is only simultaneous power-off for all outputs. To fix the resistor selection on SEQ pin before enabling the device. Any change during the power on procedure is not guarantee to the correct power-on sequence. Below table shows the power-on sequence with its corresponding resistance.

Table 3. Power-On Sequence Control

SEQ No.	Resistance on SEQ (Ω)			Sequence				
	Min	Typ	Max					
SEQ0	1.07M	1.1M	1.13M	CH1	CH4	CH3	CH2	SEQOUT
SEQ1	319k	330k	341k	CH1	CH2	CH3	SEQOUT	CH4
SEQ2	164k	169k	174k	CH1	CH2	SEQOUT	CH3	CH4
SEQ3	81.6k	84.5k	87.4k	CH1	SEQOUT	CH2	CH4	CH3
SEQ4	45.4k	47k	48.6k	CH1	CH2, CH3, CH4, SEQOUT			
SEQ5	26.1k	27k	27.9k	CH1, CH2, CH3, CH4, SEQOUT				
SEQ6	14.5k	15k	15.5k	CH1	CH3	CH2	CH4	SEQOUT
SEQ7	7.78k	8.06k	8.34k	CH1	CH3	CH4	CH2	SEQOUT
SEQ8	Short to PVCC			CH1	SEQOUT	CH2	CH3	CH4
SEQ9	Short to PGND			CH1	CH2	CH3	CH4	SEQOUT

Note :

- (1) The SEQOUT output exists only in RTQ2072A-QA. After SEQOUT output high state 1ms passed, the next channel continues to proceed power on sequence.
- (2) For RTQ2072B-QA, 1ms time interval will substitute the SEQOUT output. Below is the SEQ1 example.
 For RTQ2072A-QA, CH1 → CH2 → CH3 → SEQOUT → CH4
 For RTQ2072B-QA, CH1 → CH2 → CH3 → 1ms → CH4

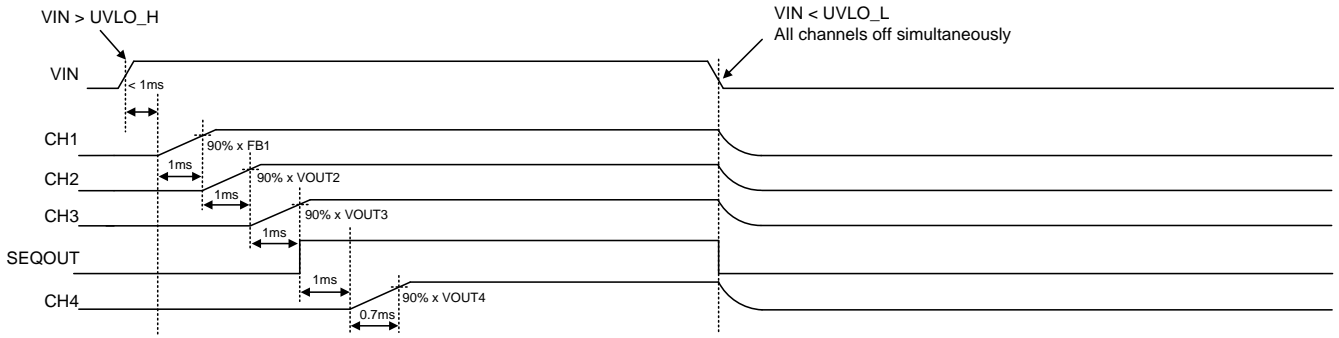

Figure 1. Example SEQ1 for RTQ2072A-QA

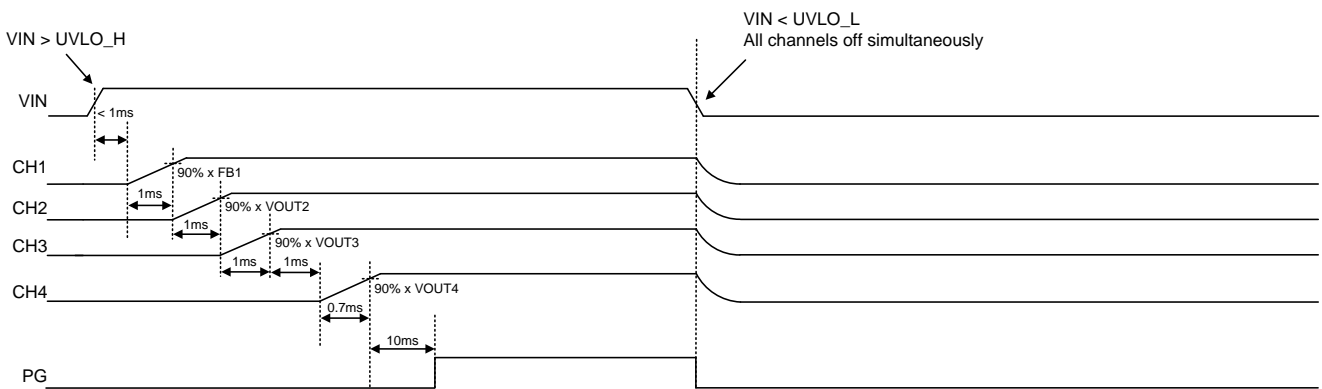

Figure 2. Example SEQ1 for RTQ2072B-QA

Output Voltage Setting

• HVBuck1

The output voltage set by external feedback resistors expressed in the following equation.

$$V_{OUT_HV1} = \left(1 + \frac{R1}{R2}\right) \times V_{FB1}$$

Where the reference voltage V_{FB1} is 0.8V (typ.)

The placement of the resistive divider should be as close as possible to the FB1 pin. For better output voltage accuracy, the divider resistors with $\pm 1\%$ tolerance or better should be used. The resistance ranges from few $k\Omega$ to hundreds of $k\Omega$ is recommended.

• LVBuck2 and LVBuck3

The output voltage of LVBuck2 is fixed 1.1V.

The output voltage of LVBuck3 is fixed 1.8V.

• LDO

The LDO output voltage is controlled by setting the dedicated resistor on RSET pin. RSET pin is not allowable at floating state and resistance selected out of range is not guaranteed to correct output voltage. Changing of the output voltage real time is not recommended. To fix the resistor selection on RSET pin before enabling the device.

Table 4. LDO Output Voltage

RSET No.	Resistor on REST (Ω)			Voltage (V)
	Min	Typ	Max	
RSET0	1.07M	1.1M	1.13M	3.5
RSET1	319k	330k	341k	3.4
RSET2	164k	169k	174k	3.2
RSET3	81.6k	84.5k	87.4k	3.1
RSET4	45.4k	47k	48.6k	3.0
RSET5	26.1k	27k	27.9k	2.8
RSET6	14.5k	15k	15.5k	2.7
RSET7	7.78k	8.06k	8.34k	1.8
RSET8	Short to PVCC			2.9
RSET9	Short to PGND			3.3

Channel Protection Features

The RTQ2072A-QA/RTQ2072B-QA equips protections to prevent the device from damages causing by abnormal operations or fault conditions. (Over-load, Short-circuit, Soldering issue...etc.)

• **Under-Voltage Protection (UVP)**

▶ **HVBuck1, LVBuck2, LVBuck3 and LDO**

The device disables all channels and enters into latch off state if step-down converter or LDO output under voltage fault detected continuously over deglitch time and the device only can re-start with V_{IN} ON/OFF.

• **Over-Voltage Protection (OVP)**

▶ **HVBuck1**

When FB1 pin over voltage fault detected, the high side and low side MOSFETs turn off immediately and auto-recover to switch until FB1 pin's voltage decrease to the reset level.

▶ **LVBuck2, LVBuck3 and LDO**

The device disables all channels when step-down converter or LDO output over voltage fault detected continuously over deglitch time. When the fault released, the device auto-restarts all channels in sequence.

• **Over-Current Protection (OCP)**

▶ **HVBuck1, LVBuck2 and LVBuck3**

The step-down converter includes a cycle-by-cycle high-side MOSFET peak current-limit protection against the condition that the inductor current increasing abnormally, even over the inductor saturation current rating. If an over-current condition occurs, the controller will immediately turn off the high-side MOSFET and turn on the low-side MOSFET to prevent the inductor current exceeding the peak current limit level. After inductor current decreasing to below the valley current limit, the high-side MOSFET resume switching on. If over current fault further detected continuously over than deglitch time, the device disables all channels and enters into latch off state and the device only can re-start with V_{IN} ON/ OFF.

▶ **LDO**

When the load reaches the current limit threshold, the current sent to the output will kept at current limit level. If over-current fault detected continuously over than the deglitch time, the device disables all channels and enters into latch off state and the device only can re-start with V_{IN} ON/ OFF.

• **Input Over-Voltage Protection (OVP)**

▶ **LVBuck2, LVBuck3 and LDO**

If the input voltage of step-down converters (LVBuck2, LVBuck3) or LDO reaches over-voltage protection level, the device disables all channels. After fault removed, it auto-restarts all channels in sequence.

Table 5. Protection

Channel	Type	Threshold (Typ.)	Deglintch Time (Typ.)	Protection	Reset and Threshold (Typ.)
System	UVLO	$V_{IN} \leq 3.3V$ (after IC Operation)	32 μ s	Disable all channels	$V_{IN} \geq 3.8V$
	OVP	$V_{IN} \geq 20V$	5ms	Disable all channels then latch-off protection	$V_{IN} \leq 3.3V$, then $V_{IN} \geq 3.8V$
	OTP	$T_J \geq 160^\circ C$	5 μ s	Disable all channels then latch-off protection	$T_J \leq 140^\circ C$ and $V_{IN} \leq 3.3V$, then $V_{IN} \geq 3.8V$
CH1 HVBuck1	UVP	$V_{FB1} \leq 0.8V \times 50\%$	5 μ s	Disable all channels then latch-off protection	$V_{IN} \leq 3.3V$, then $V_{IN} \geq 3.8V$
	OVP	$V_{FB1} \geq 0.8V \times 110\%$	NA	High/Low-side MOSFETs off, low-side MOSFET conditionally ON to charge the BOOT capacitor for driving high-side MOSFET.	$V_{FB1} < 0.8V \times 110\%$
	OCP	$I_{L1_peak} \geq 3A$	10ms	Cycle-by-cycle detection If keep 10ms, disable all channels then latch-off protection	If latch-off protection, $V_{IN} \leq 3.3V$, then $V_{IN} \geq 3.8V$
CH2 LVBuck2	UVP	$V_{OUT_LV2} \leq 1.1V \times 50\%$	5 μ s	Disable all channels then latch-off protection	$V_{IN} \leq 3.3V$, then $V_{IN} \geq 3.8V$
	OVP	$V_{OUT_LV2} \geq 1.1V \times 120\%$	5ms	Disable all channels	$V_{OUT2} \leq 1.1V \times 110\%$ with deglitch 5ms
	OCP	$I_{L2_peak} \geq 2A$	10ms	Cycle-by-cycle detection If keep 10ms, disable all channels then latch-off protection	If latch-off protection, $V_{IN} \leq 3.3V$, then $V_{IN} \geq 3.8V$
	Input OVP	$V_{IN_PVD23} \geq 5.8V$	5 μ s	Disable all channels	$V_{IN_PVD23} \leq 5.22V$ with deglitch 5 μ s
CH3 LVBuck3	UVP	$V_{OUT_LV3} \leq 1.8V \times 50\%$	5 μ s	Disable all channels then latch-off protection	$V_{IN} \leq 3.3V$, then $V_{IN} \geq 3.8V$
	OVP	$V_{OUT_LV3} \geq 1.8V \times 120\%$	5ms	Disable all channels	$V_{OUT3} \leq 1.8V \times 110\%$ with deglitch 5ms
	OCP	$I_{L3_peak} \geq 1.2A$	10ms	Cycle-by-cycle detection If keep 10ms, disable all channels then latch-off protection	If latch-off protection, $V_{IN} \leq 3.3V$, then $V_{IN} \geq 3.8V$
	Input OVP	$V_{IN_PVD23} \geq 5.8V$	5 μ s	Disable all channels	$V_{IN_PVD23} \leq 5.22V$ with deglitch 5 μ s

Channel	Type	Threshold (Typ.)	Deglintch Time (Typ.)	Protection	Reset and Threshold (Typ.)
CH4 LDO	UVP	$V_{OUT_LDO} \leq V_{OUT_LDO} \text{ setting} \times 40\%$	5 μ s	Disable all channels then latch-off protection	$V_{IN} \leq 3.3V$, then $V_{IN} \geq 3.8V$
	OVP	$V_{OUT_LDO} \geq V_{OUT_LDO} \times 125\%$	5ms	Disable all channels	$V_{OUT_LDO} \leq V_{OUT_LDO} \times 110\%$ with deglitch 5ms
	OCP	$I_{OUT_LDO} \geq 450mA$	10ms	Disable all channels then latch-off protection	$V_{IN} \leq 3.3V$, then $V_{IN} \geq 3.8V$
	Input OVP	$V_{IN_LDO} \geq 5.8V$	5 μ s	Disable all channels	$V_{IN_LDO} \leq 5.3V$ with deglitch 5 μ s

Input and Output Capacitor Selection

• **HVBuck1, LVBuck2 and LVBuck3**

It is recommended at least a 4.7 μ F input capacitor with a 10 μ F output capacitor for step-down converters. The ripple voltage is an important index for choosing output capacitor. This portion consists of two parts. One is the product of ripple current with the ESR of the output capacitor, while the other part is formed by the charging and discharging process of the output capacitor. The output ripple can be calculated as below.

$$\Delta V_{OUT\text{Ripple}} = \Delta V_{ESR} + \Delta V_{OUT} = \Delta V_{ESR} + \frac{\Delta I_L}{8 \times C_{OUT} \times f_{SW}}$$

where $\Delta V_{ESR} = I_{C\text{rms}} \times R_{CESR}$

• **LDO**

Like any low dropout regulator, the external capacitor of the RTQ2072A-QA/RTQ2072B-QA must be carefully selected for regulator stability and performance. Using a 2.2 μ F capacitor for the LDO’s input and output is suitable.

Additional capacitor paralleled on the output may get better noise suppression but also lead to higher input inrush current when LDO outputs. It should be taken into consideration carefully.

Thermal Considerations

The junction temperature should never exceed the absolute maximum junction temperature $T_{J(MAX)}$, listed under Absolute Maximum Ratings, to avoid permanent damage to the device. The maximum allowable power dissipation depends on the thermal resistance of the IC

package, the PCB layout, the rate of surrounding airflow, and the difference between the junction and ambient temperatures. The maximum power dissipation can be calculated using the following formula :

$$P_{D(MAX)} = (T_{J(MAX)} - T_A) / \theta_{JA}$$

where $T_{J(MAX)}$ is the maximum junction temperature; T_A is the ambient temperature; and θ_{JA} is the junction-to-ambient thermal resistance.

For continuous operation, the maximum operating junction temperature indicated under Recommended Operating Conditions is 150°C. The junction-to-ambient thermal resistance, θ_{JA} , is highly package dependent. For a WETD-VQFN-16L 3x3 package, the thermal resistance, θ_{JA} , is 30°C/W on a standard JEDEC 51-7 high effective-thermal-conductivity four-layer test board. The maximum power dissipation at $T_A = 25^\circ\text{C}$ can be calculated as below :

$$P_{D(MAX)} = (150^\circ\text{C} - 25^\circ\text{C}) / (30^\circ\text{C/W}) = 4.16W \text{ for a WETD-VQFN-16L 3x3 package.}$$

The maximum power dissipation depends on the operating ambient temperature for the fixed $T_{J(MAX)}$ and the thermal resistance, θ_{JA} . The derating curves in Figure 3 allows the designer to see the effect of rising ambient temperature on the maximum power dissipation.

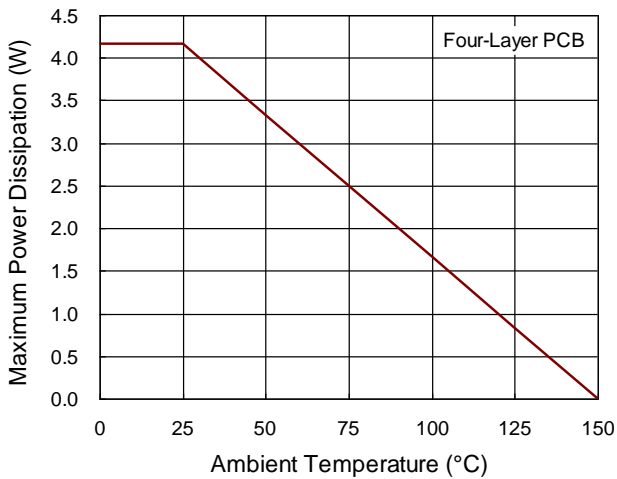

Figure 3. Derating Curve of Maximum Power Dissipation

Layout Considerations

The PCB layout is an important step to maintain the high performance of the RTQ2072A-QA/RTQ2072B-QA. Both the high current and the fast switching nodes demand full attention to the PCB layout to keep the robustness of the RTQ2072A-QA/RTQ2072B-QA through the PCB layout. Improper layout might lead to the symptoms of poor line or load

regulation, ground and output voltage shifts, stability issues, unsatisfying EMI behavior or worsened efficiency. For the best performance of the RTQ2072A-QA/RTQ2072B-QA, the following PCB layout guidelines must be strictly followed.

- ▶ The trace from switching node to inductor should be as short as possible to minimized the switching loop for better EMI.
- ▶ Place the input and output capacitors close to the input and output pins respectively for good filtering.
- ▶ Keep the main power traces as wide and short as possible.
- ▶ Connect the AGND and PGND to a strong ground plane for maximum thermal dissipation and noise protection.
- ▶ Directly connect the step-down converter’s output capacitor to the feedback network to avoid bouncing caused by parasitic resistance and inductance from the PCB trace.

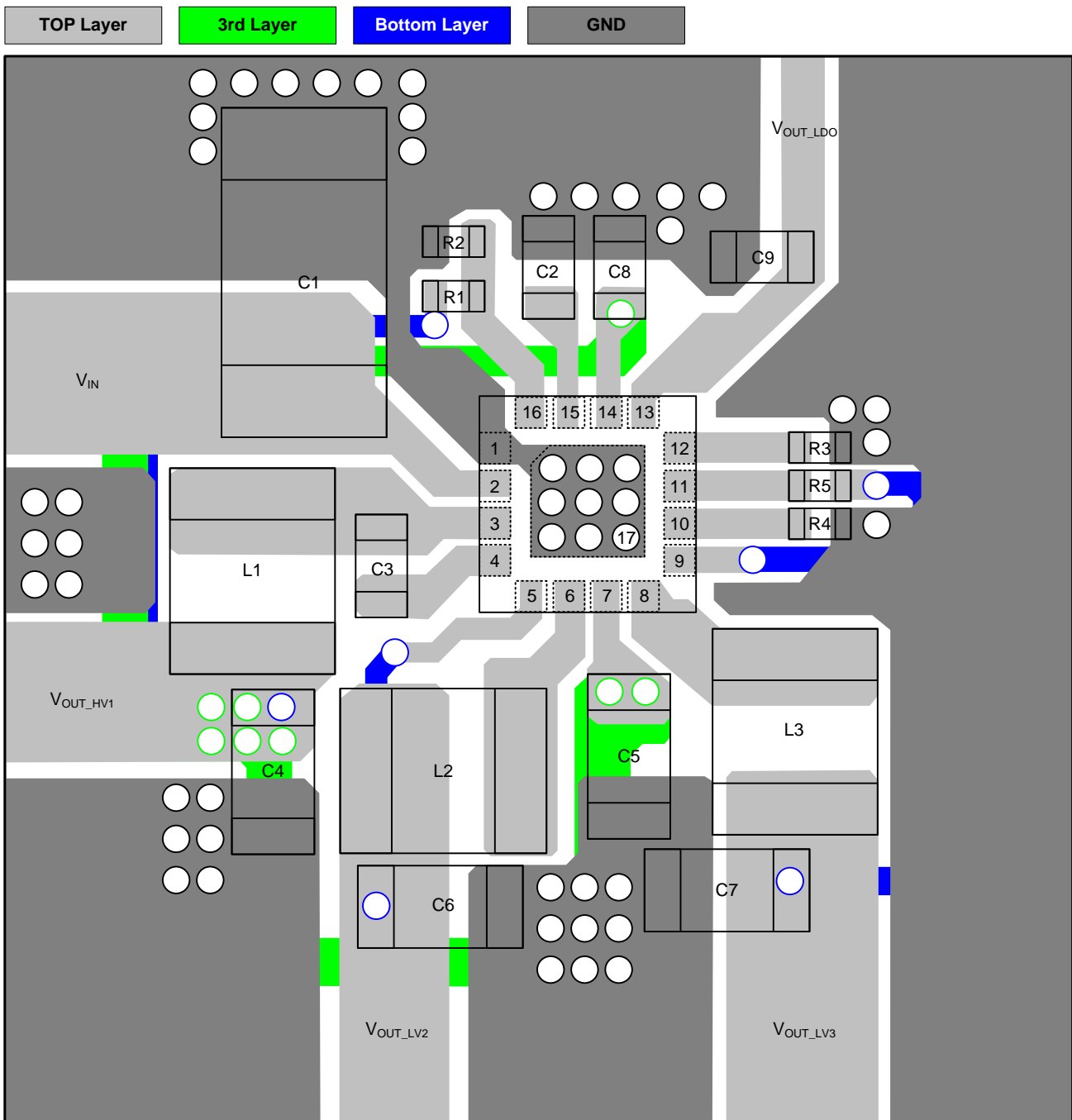
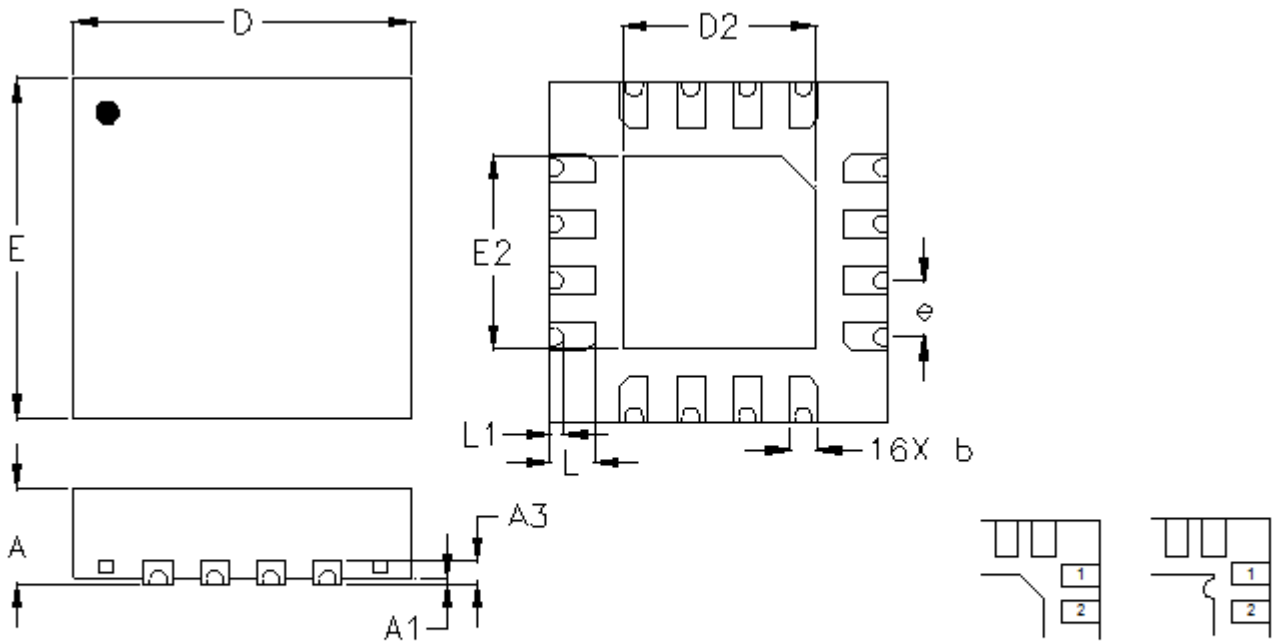

Figure 4. PCB Layout Guide

Outline Dimension



DETAIL A

Pin #1 ID and Tie Bar Mark Options

Note : The configuration of the Pin #1 identifier is optional, but must be located within the zone indicated.

Symbol	Dimensions In Millimeters		Dimensions In Inches	
	Min	Max	Min	Max
A	0.800	1.000	0.031	0.039
A1	0.000	0.050	0.000	0.002
A3	0.175	0.250	0.007	0.010
b	0.180	0.300	0.007	0.012
D	2.950	3.050	0.116	0.120
D2	1.650	1.750	0.065	0.069
E	2.950	3.050	0.116	0.120
E2	1.650	1.750	0.065	0.069
e	0.500		0.020	
L	0.350	0.450	0.014	0.018
L1	0.075	0.175	0.003	0.007

WETD V-Type 16L QFN 3x3 Package

Footprint Information

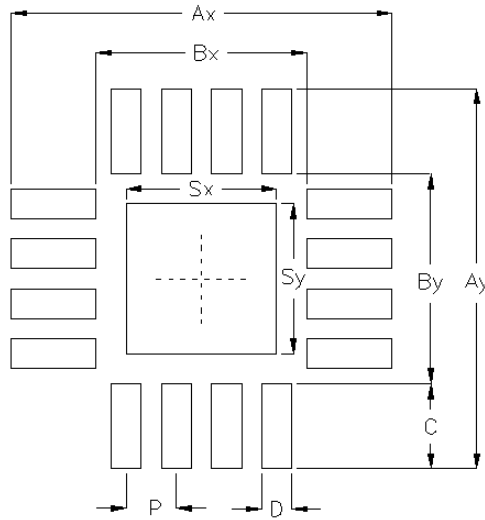

Package	Number of Pin	Footprint Dimension (mm)									Tolerance
		P	Ax	Ay	Bx	By	C	D	Sx	Sy	
WETD-V/W/U/XQFN3x3-16	16	0.50	3.80	3.80	2.10	2.10	0.85	0.30	1.50	1.50	±0.05

Packing Information

Tape and Reel Data

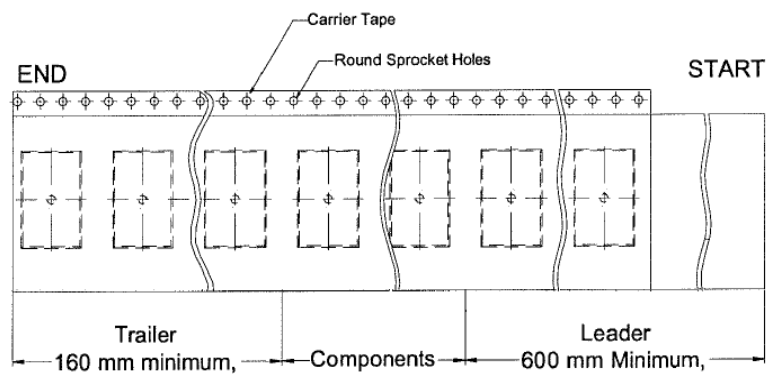
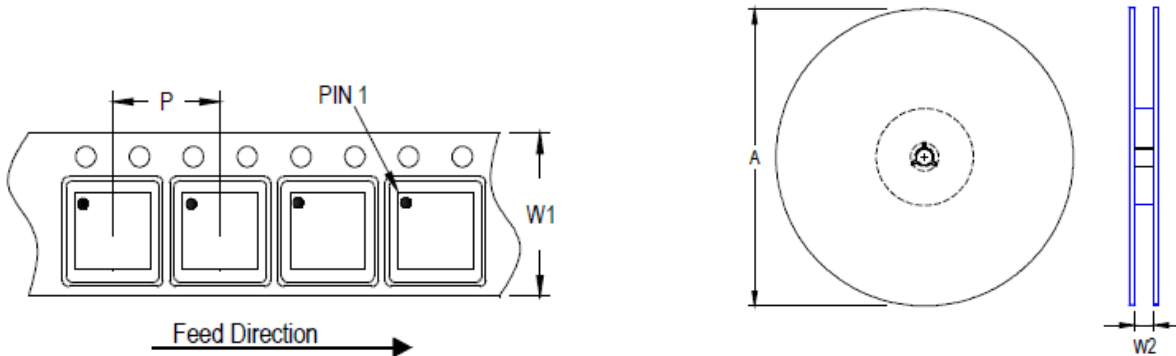



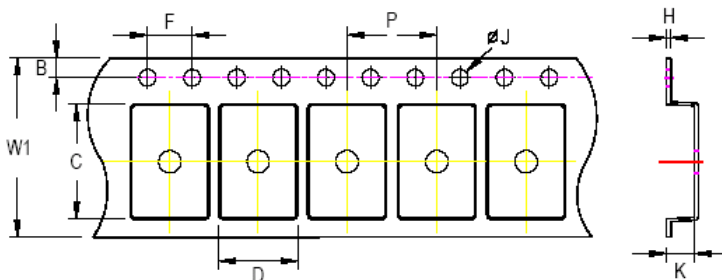



Package Type	Tape Size (W1) (mm)	Pocket Pitch (P) (mm)	Reel Size (A)		Units per Reel	Trailer (mm)	Leader (mm)	Reel Width (W2) Min./Max. (mm)
			(mm)	(in)				
QFN/DFN 3x3	12	8	180	7	1,500	160	600	12.4/14.4



C, D and K are determined by component size.
The clearance between the components and the cavity is as follows:
- For 12mm carrier tape: 0.5mm max.

Tape Size	W1	P		B		F		ØJ		H
	Max.	Min.	Max.	Min.	Max.	Min.	Max.	Min.	Max.	Max.
12mm	12.3mm	7.9mm	8.1mm	1.65mm	1.85mm	3.9mm	4.1mm	1.5mm	1.6mm	0.6mm

Tape and Reel Packing

Step	Photo/Description	Step	Photo/Description
1	 <p>Reel 7"</p>	4	 <p>3 reels per inner box Box A</p>
2	 <p>HIC & Desiccant (1 Unit) inside</p>	5	 <p>12 inner boxes per outer box</p>
3	 <p>Caution label is on backside of Al bag</p>	6	 <p>Outer box Carton A</p>

Package	Reel		Box				Carton			
	Size	Units	Item	Size(cm)	Reels	Units	Item	Size(cm)	Boxes	Unit
QFN & DFN 3x3	7"	1,500	Box A	18.3*18.3*8.0	3	4,500	Carton A	38.3*27.2*38.3	12	54,000
			Box E	18.6*18.6*3.5	1	1,500	For Combined or Partial Reel.			

Packing Material Anti-ESD Property

Surface Resistance	Aluminum Bag	Reel	Cover tape	Carrier tape	Tube	Protection Band
Ω/cm^2	10^4 to 10^{11}	10^4 to 10^{11}	10^4 to 10^{11}	10^4 to 10^{11}	10^4 to 10^{11}	10^4 to 10^{11}

Richtek Technology Corporation

14F, No. 8, Tai Yuen 1st Street, Chupei City

Hsinchu, Taiwan, R.O.C.

Tel: (8863)5526789

Richtek products are sold by description only. Richtek reserves the right to change the circuitry and/or specifications without notice at any time. Customers should obtain the latest relevant information and data sheets before placing orders and should verify that such information is current and complete. Richtek cannot assume responsibility for use of any circuitry other than circuitry entirely embodied in a Richtek product. Information furnished by Richtek is believed to be accurate and reliable. However, no responsibility is assumed by Richtek or its subsidiaries for its use; nor for any infringements of patents or other rights of third parties which may result from its use. No license is granted by implication or otherwise under any patent or patent rights of Richtek or its subsidiaries.

Copyright © 2023 Richtek Technology Corporation. All rights reserved. **RICHTEK** is a registered trademark of Richtek Technology Corporation.

Datasheet Revision History

Version	Date	Description	Item
02	2023/7/31	Modify	Ordering Information on P1 Electrical Characteristics on P9 Application Information on P19 Packing Information on P28, 29, 30