

# Wireless Power Transmitter Controller for WPC BPP/EPP Solution

## General Description

The RT3181A is a highly integrated and scalable solution for wireless power transmitter applications for WPC/Qi, the mainstream standard today. The RT3181A can be configured to various type of transmitter in WPC definition.

- Single chip A11/a BPP TX, H-Bridge FETs integrated.
- A11/a BPP TX with external power stage
- A28/a multi-coil BPP TX
- Voltage rail control EPP TX, eg, MPA5, MPA11
- Frequency control EPP TX, eg, MPA2
- Wide input range for QC/PD TA input

## Ordering Information

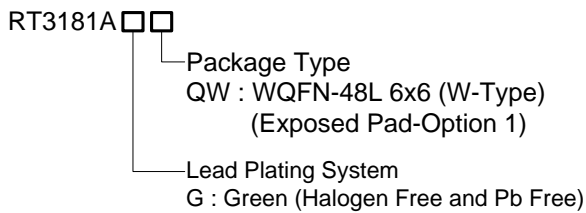

Note :

Richtek products are :

- ▶ RoHS compliant and compatible with the current requirements of IPC/JEDEC J-STD-020.
- ▶ Suitable for use in SnPb or Pb-free soldering processes.

## Marking Informaton

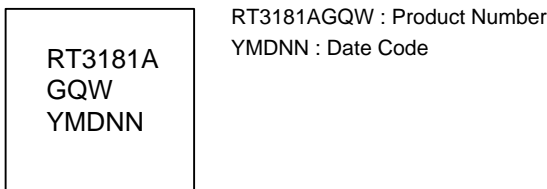

## Features

- Internal Flash for Easy Design and Firmware Upgrade
- Coil Driver
  - ▶ High Integration with Internal H-Bridge Power Stage and Current Sense Amplifier, Optimized for BPP A11 Solution
  - ▶ High Power with External Power Stage, with DrMOS or Discrete Gate Driver and MOSFETs
- DCDC Controller
  - ▶ Integrated Sync. Gate Driver
  - ▶ Drive External Dual NFET
  - ▶ Flexible to Configure as Sync. Buck or Sync Boost Converter
- EU EMC Compliant Solution
- Low Quiescent Current Plus
  - ▶ Selectable Ping Cycle in Custom Applications
  - ▶ Low Current Sleep Mode Options Including “Off” State with Wake Up I/O Pin
- Bi-Direction Communication Support, ASK and FSK
- Programmable thermal protection
- Support Foreign Object Detection, Q factor measurement and Field strength
- Notifications :
  - ▶ 1 Buzzer
  - ▶ 2 LEDs, Resistor Programmable
- Two I<sup>2</sup>C Interface, Master and Slave
- Reserved Interface for NFC/BT/WiFi Module Expansion
- Internal Watchdog Timer
- WQFN-48L 6x6mm package

Simplified Application Circuit

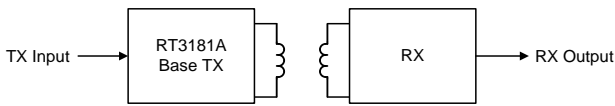

RT3181A Transmitter Efficiency (MP-A5)

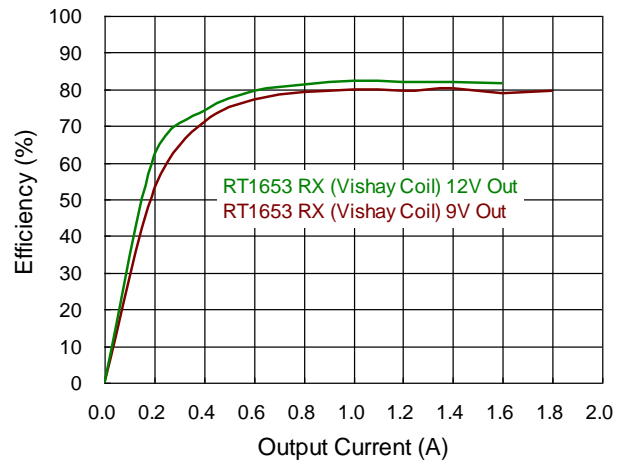

Pin Configuration

(TOP VIEW)

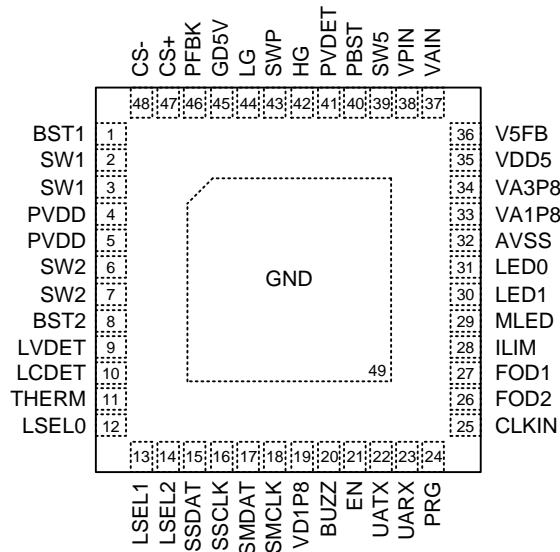

WQFN-48L 6x6

**Typical Application Circuit**

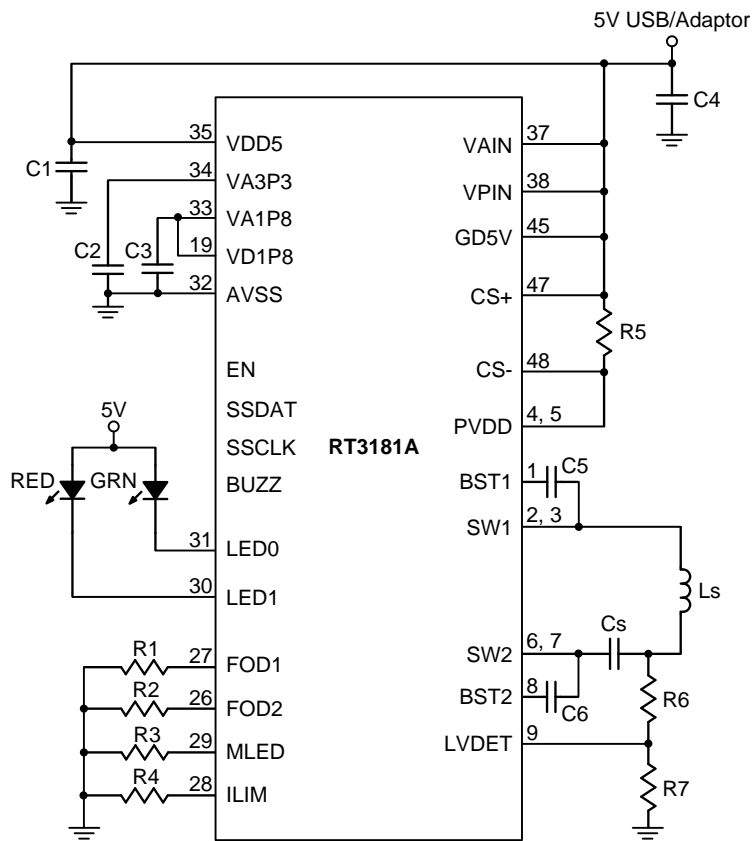

Figure 1. WPC LP A11 Minimized BOM Transmitter Application Circuit

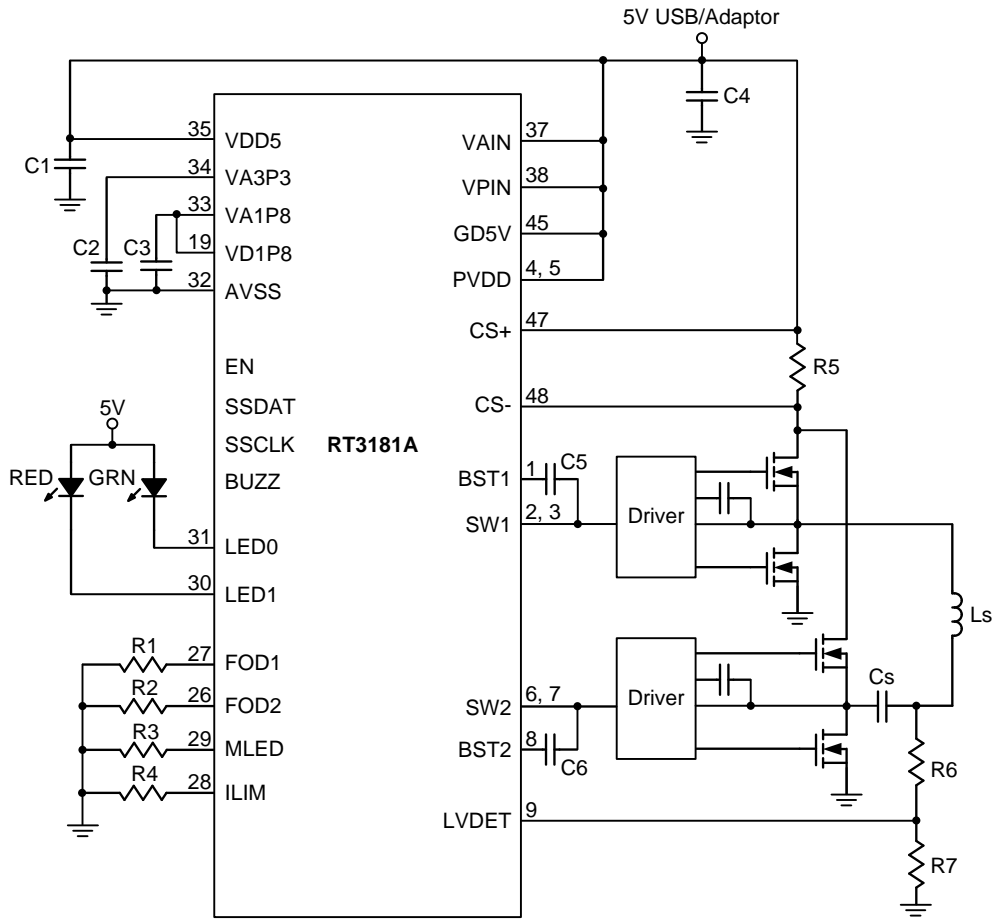

Figure 1. WPC LP A11 High Performance Transmitter Application Circuit

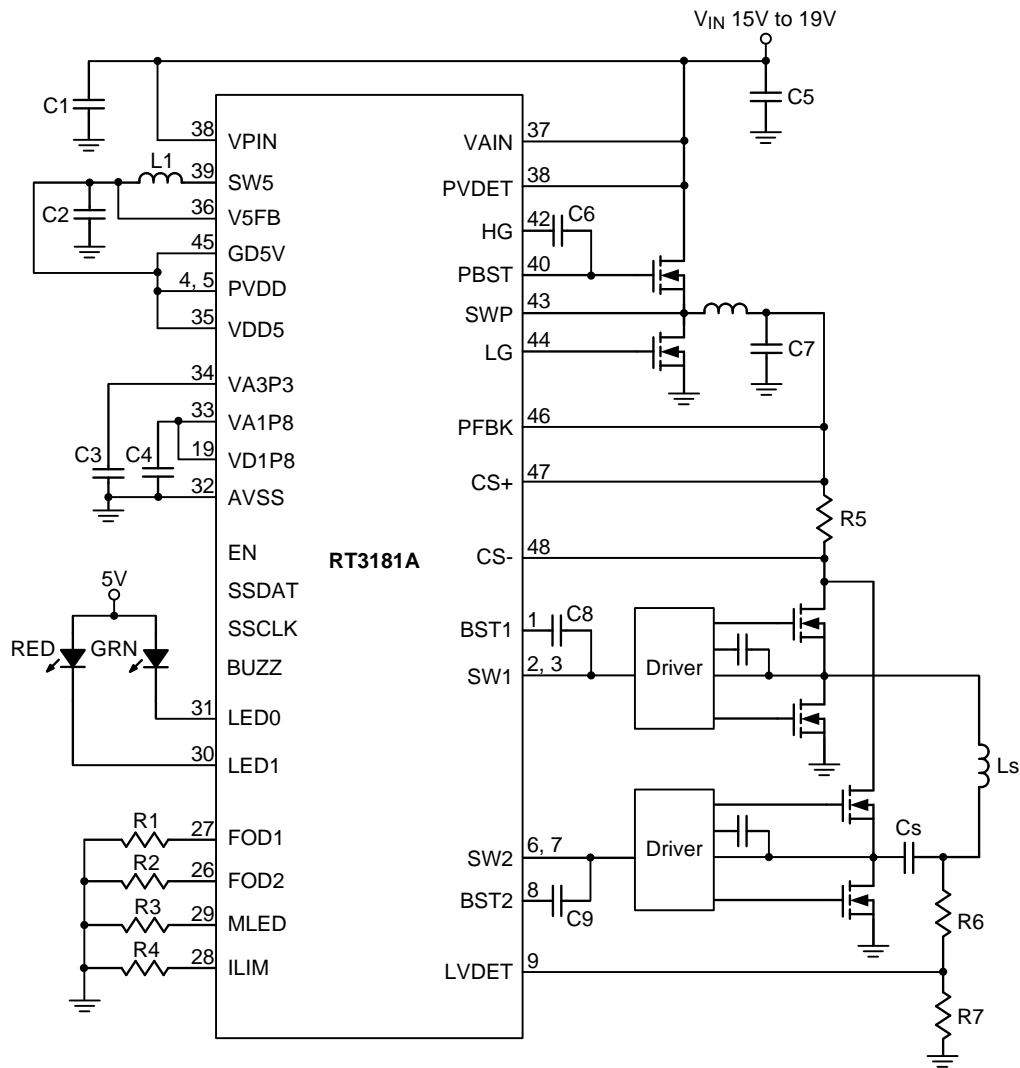
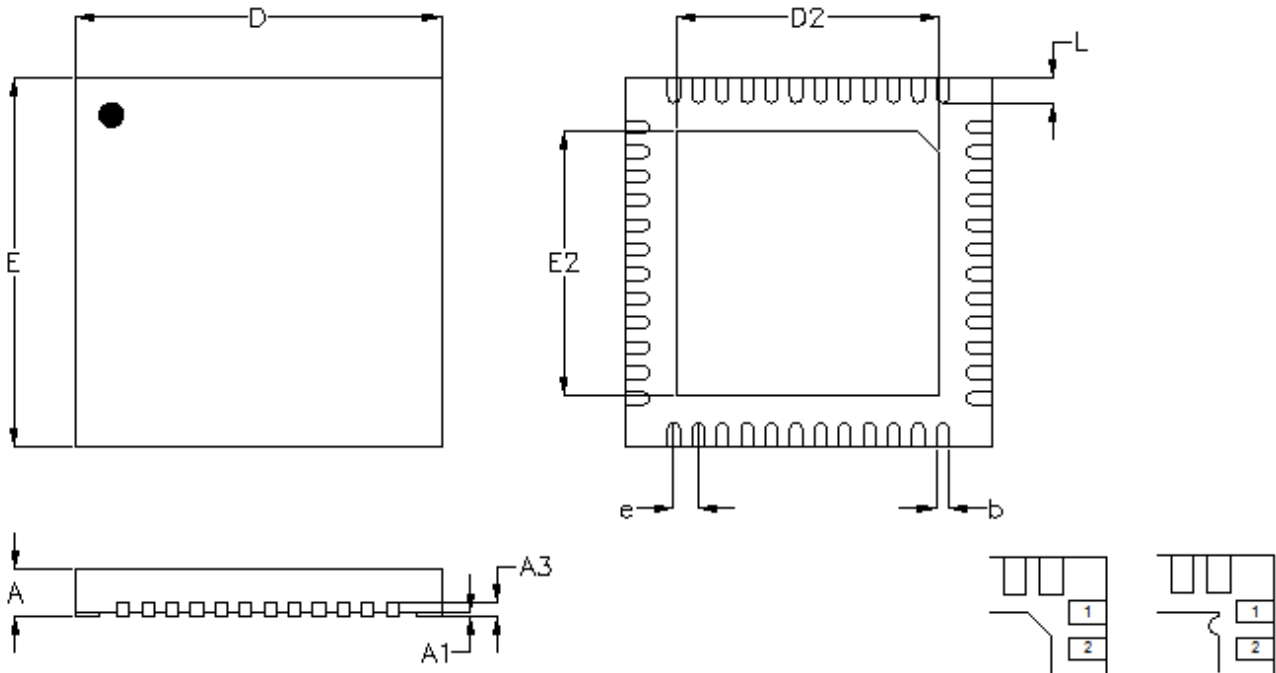

Figure 3. WPC MP-A5 Transmitter Application Circuit

Outline Dimension



**DETAIL A**

Pin #1 ID and Tie Bar Mark Options

Note : The configuration of the Pin #1 identifier is optional, but must be located within the zone indicated.

Symbol	Dimensions In Millimeters		Dimensions In Inches		
	Min	Max	Min	Max	
A	0.700	0.800	0.028	0.031	
A1	0.000	0.050	0.000	0.002	
A3	0.175	0.250	0.007	0.010	
b	0.150	0.250	0.006	0.010	
D	5.950	6.050	0.234	0.238	
D2	Option 1	4.250	4.350	0.167	0.171
	Option 2	4.350	4.450	0.171	0.175
E	5.950	6.050	0.234	0.238	
E2	Option 1	4.250	4.350	0.167	0.171
	Option 2	4.350	4.450	0.171	0.175
e	0.400		0.016		
L	0.350	0.450	0.014	0.018	

**W-Type 48L QFN 6x6 Package**

**Richtek Technology Corporation**

14F, No. 8, Tai Yuen 1<sup>st</sup> Street, Chupei City

Hsinchu, Taiwan, R.O.C.

Tel: (8863)5526789

Richtek products are sold by description only. Richtek reserves the right to change the circuitry and/or specifications without notice at any time. Customers should obtain the latest relevant information and data sheets before placing orders and should verify that such information is current and complete. Richtek cannot assume responsibility for use of any circuitry other than circuitry entirely embodied in a Richtek product. Information furnished by Richtek is believed to be accurate and reliable. However, no responsibility is assumed by Richtek or its subsidiaries for its use; nor for any infringements of patents or other rights of third parties which may result from its use. No license is granted by implication or otherwise under any patent or patent rights of Richtek or its subsidiaries.

---

Copyright © 2017 Richtek Technology Corporation. All rights reserved. **RICHTEK** is a registered trademark of Richtek Technology Corporation.